

## 3D Cadastre

September, 2004

Cover design: Axel Smits

This PhD thesis is published under the same title in the series:

Publications on Geodesy 57

ISBN 90 6132 286 3

NCG, Netherlands Geodetic Commission

P.O. Box 5058

Delft, the Netherlands

E-mail: [ncg@lr.tudelft.nl](mailto:ncg@lr.tudelft.nl)

Website: [www.ncg.knaw.nl](http://www.ncg.knaw.nl)

# 3D Cadastre

Proefschrift

ter verkrijging van de graad van doctor  
aan de Technische Universiteit Delft,  
op gezag van de Rector Magnificus prof.dr.ir. J.T. Fokkema,  
voorzitter van het College voor Promoties,  
in het openbaar te verdedigen  
op maandag 13 september 2004 te 10:30 uur

door

Jantine Esther STOTER

doctorandus Fysische Geografie

geboren te Hoogeveen

Dit proefschrift is goedgekeurd door de promotoren:  
Prof.dr.ir. P.J.M. van Oosterom  
Prof.dr. J. de Jong

Samenstelling promotiecommissie:

Rector Magnificus, voorzitter  
Prof.dr.ir. P.J.M. van Oosterom, Technische Universiteit Delft, promotor  
Prof.dr. J. de Jong, Technische Universiteit Delft, promotor  
Prof.dr. P.J. Boelhouwer, Technische Universiteit Delft  
Prof.dr.tech. H.E. Mattsson, Royal Insitute of Technology, Sweden  
Prof.dr.ir. M. Molenaar, ITC  
Prof.dr. H.F.L. Ottens, Universiteit Utrecht  
Dr.ir. M.A. Salzmann, Kadaster, Apeldoorn

Dr. H.D. Ploeger heeft als begeleider in belangrijke mate aan de totstandkoming van het proefschrift bijgedragen.

# Acknowledgements

I could never have finished this work without the support of a group of very pleasant people and I feel privileged that I was able to work with them. I would like to thank all the people who contributed either directly or indirectly to this work. However, there are a few people who I would like to specifically mention here.

First of all I would like to thank Peter van Oosterom. His enthusiasm stimulated me to do this research with great enjoyment and our discussions were very inspiring for me. Hendrik Ploeger contributed largely to this thesis by discussing my findings using his juridical expertise. I would like to thank Sisi Zlatanova because we collaborated (from my side with great pleasure) on different topics of this thesis. Wilko Quak and Theo Thijssen were indispensable during my research because they were always available assisting me in all kinds of technical issues (they never said ‘no’, ‘maybe’ or ‘later’). Marian de Vries supported me in the Internet part of my research. I cooperated with Ben Gorte on the terrain modelling issues. I am grateful to Jitkse de Jong for giving me supervision on juridical matters. Axel Smits assisted me in preparing the illustrations in this thesis, he also designed the cover.

I would like to thank all other members of the section GIS technology as well as the members of the section Geo-information and Land Development because they contributed to the motivating environment in which I was able to perform this research.

The Kadaster cooperated in this research by providing me with data and by discussions on data models and on research developments. I am grateful to the following persons of the Netherlands’ Kadaster: Auke Hoekstra, Zacharias Klaasse, Martin Salzman, and Berry van Osch. Piet Beekman from the cadastral office in Zuid-Holland was very valuable because he provided me with all the cadastral information needed for the Dutch case studies.

I worked with people from the Danish cadastre (KMS) in Copenhagen and the Centre for 3D GeoInformation in Aalborg on the case study in Denmark.

The following persons provided me with useful comments about the contents of this thesis: Elfriede Fendel, Hans-Gerd Maas and Jaap Zevenbergen.

Rod Thompson of the Department of Natural Resources, Mines and Energy (Queensland Government) provided me with data sets needed for the Queensland case study. Moreover, Rod did a great job because he gave me advice on the English text of this thesis. Also George Sithole: thanks for your suggestions on the English text.

I thank the companies Laser-Scan, Oracle, ESRI and Bentley for their collaboration in this research and because I was able to use their software. In addition they gave me advice on technical issues.

I appreciate the contribution of the NAM (*Nederlandse Aardolie Maatschappij*), the project-team of the *HSL-Zuid* and the *Bouwdienst van Rijkswaterstaat* because they provided me with 3D data on physical constructions for the case studies. AGI (*Adviesdienst Geo-informatie en ICT*) provided me with point heights of case study areas.

Calin Arens, Friso Penninga and Erik van Nieuwburg contributed to several issues in this thesis (respectively the polyhedron implementation, the effective filtering of a TIN and the Internet application to query a database) as part of their MSc programme, Friso the last few months as a colleague.

Finally there are a number of people who supported me in finishing this thesis in a more indirect way. To have these people around me give me the possibility to explore and experience the things in life that are essential to me. First of all I would like to thank Riet, Roel, Suzan and Marije (my family). They gave me the possibility in the first place to start my education and study and they always support me in doing what I find important to do. Secondly, I would like to thank all my inspiring friends who I either meet frequently or rarely. These contacts were very important to me during my research. There are two people who I like to mention specifically. Madeleine was essential for me during this period because of our spiritual discussions, her stimulation, and laughter. Finally, Gerbert, my soulmate, was of great importance to me because of his practical and mental support, his encouragement and understanding.

# Contents

<b>1</b>	<b>Introduction</b>	<b>1</b>
1.1	Need for a 3D cadastre . . . . .	3
1.2	Research scope . . . . .	7
1.2.1	Topics within the scope of this thesis . . . . .	7
1.2.2	Topics outside the scope of this thesis . . . . .	9
1.3	Research approach . . . . .	9
1.3.1	Research objectives . . . . .	9
1.3.2	Research methods . . . . .	10
1.4	Previous and related research . . . . .	11
1.4.1	Related research on 3D cadastres . . . . .	11
1.4.2	Related research on 3D tools and 3D modelling . . . . .	11
1.5	Contribution of the work . . . . .	12
1.6	Organisation of the thesis . . . . .	13
<b>I</b>	<b>Analysis of the background</b>	<b>17</b>
<b>2</b>	<b>Current cadastral registration of 3D situations in the Netherlands</b>	<b>19</b>
2.1	Different types of cadastral registrations . . . . .	20
2.2	The Netherlands' Kadaster . . . . .	24
2.2.1	Organisation of the Netherlands' Kadaster . . . . .	24
2.2.2	Public Registers and cadastral registration . . . . .	25
2.2.3	Cadastral model . . . . .	25
2.2.4	Mapping real world objects . . . . .	26
2.3	3D registration and Private Law . . . . .	27

2.3.1	Right of ownership . . . . .	27
2.3.2	Right of superficies . . . . .	30
2.3.3	Right of long lease . . . . .	31
2.3.4	Right of easement . . . . .	31
2.3.5	Apartment right . . . . .	32
2.3.6	Joint ownership . . . . .	34
2.4	3D registration and Public Law . . . . .	34
2.4.1	Belemmeringenwet Privaatrecht . . . . .	35
2.4.2	Law on Monuments . . . . .	37
2.4.3	Law on Soil Protection . . . . .	38
2.5	Other relevant aspects of cadastral registration . . . . .	38
2.5.1	Underground objects in the cadastral registration . . . . .	38
2.5.2	Parcels and part parcels . . . . .	39
2.5.3	Frequency of types of cadastral recordings . . . . .	40
2.6	Conclusions . . . . .	41
<b>3</b>	<b>Current practice of 3D registration: case studies</b>	<b>45</b>
3.1	Building complexes . . . . .	46
3.1.1	Case study 1: Building complex in The Hague . . . . .	46
3.1.2	Case study 2: The Hague Central Station . . . . .	47
3.1.3	Case study 3: Apartment complex . . . . .	49
3.2	Subsurface infrastructure objects . . . . .	51
3.2.1	Case study 4: Railway tunnel and station in urban area . . . . .	52
3.2.2	Case study 5: Railway tunnel in rural area . . . . .	54
3.2.3	Case study 6: Utility pipelines . . . . .	55
3.3	Conclusions . . . . .	57
<b>4</b>	<b>3D cadastre abroad</b>	<b>59</b>
4.1	3D cadastral registrations abroad . . . . .	59
4.2	Evaluating 3D cadastral issues in the Netherlands . . . . .	62
4.3	Denmark . . . . .	63
4.3.1	Evaluating 3D cadastral issues in Denmark . . . . .	64
4.4	Norway . . . . .	65



4.4.1	Evaluating 3D cadastral issues in Norway . . . . .	67
4.5	Sweden . . . . .	68
4.5.1	Evaluating 3D cadastral issues in Sweden . . . . .	70
4.6	Queensland, Australia . . . . .	70
4.6.1	Restricted, building and volumetric parcels . . . . .	71
4.6.2	A case study in Queensland . . . . .	73
4.6.3	Evaluating 3D cadastral issues in Queensland . . . . .	74
4.7	British Columbia, Canada . . . . .	76
4.7.1	Evaluating 3D cadastral issues in British Columbia . . . . .	77
4.8	Israel . . . . .	78
4.8.1	Evaluating 3D cadastral issues in Israel . . . . .	79
4.9	Conclusions . . . . .	80
<b>5</b>	<b>Needs and opportunities for a 3D cadastre</b>	<b>83</b>
5.1	Current cadastral registration of 3D situations in the Netherlands . . . . .	84
5.2	Complexities of current cadastral registration . . . . .	85
5.2.1	Complexities of current Dutch cadastral registration . . . . .	86
5.2.2	Locating infrastructure objects in the current cadastre . . . . .	88
5.3	Basic needs for a 3D cadastre . . . . .	89
5.4	Opportunities for a 3D cadastre . . . . .	91
5.5	3D applications outside the cadastral domain . . . . .	92
5.6	Conclusions . . . . .	94
<b>II</b>	<b>Framework for modelling 2D and 3D situations</b>	<b>97</b>
<b>6</b>	<b>Theory of spatial data modelling</b>	<b>99</b>
6.1	Data models . . . . .	99
6.1.1	Data models in GIS . . . . .	101
6.1.2	Design phases in modelling . . . . .	103
6.2	Conceptual model . . . . .	103
6.3	Logical model . . . . .	104
6.3.1	Relational model . . . . .	104
6.3.2	Object oriented model . . . . .	105

6.3.3	Object relational model . . . . .	107
6.4	Physical model . . . . .	108
6.5	UML . . . . .	109
6.6	Spatial data modelling and DBMS . . . . .	112
6.7	Standardisation initiatives . . . . .	113
6.7.1	OpenGIS Consortium . . . . .	114
6.7.2	ISO TC/211 . . . . .	117
6.7.3	CEN/TC 287 . . . . .	119
6.8	Conclusions . . . . .	119
<b>7</b>	<b>Geo-DBMSs</b>	<b>121</b>
7.1	Geometrical primitives in DBMSs . . . . .	122
7.1.1	2D geometrical primitives in DBMSs . . . . .	122
7.1.2	3D geometrical primitives in DBMSs . . . . .	124
7.2	Topological structure in DBMSs . . . . .	127
7.2.1	OGC, ISO and planar partition topology . . . . .	128
7.2.2	User-defined DBMS implementation of 2D topological structure	129
7.2.3	Commercial DBMS implementation of 2D topological structure	138
7.2.4	User-defined DBMS implementation of 3D topological structure	139
7.3	Spatial analyses in DBMSs . . . . .	141
7.3.1	2D spatial analyses using geometrical primitives . . . . .	142
7.3.2	3D spatial analyses using geometrical primitives . . . . .	144
7.3.3	Spatial analyses using the topological structure . . . . .	145
7.3.4	Case study: topological structure or geometrical primitives? . .	146
7.4	Implementation of a 3D geometrical primitive in a DBMS . . . . .	148
7.4.1	Definition of 3D primitive . . . . .	149
7.4.2	Validation . . . . .	152
7.4.3	Spatial indexing in 3D . . . . .	156
7.4.4	3D functions . . . . .	158
7.5	Conclusions . . . . .	159
<b>8</b>	<b>3D GIS and accessing a 3D geo-DBMS with front-ends</b>	<b>163</b>
8.1	3D GIS . . . . .	164

---

8.1.1	Organisation of 3D data . . . . .	164
8.1.2	3D data collection and object reconstruction . . . . .	165
8.1.3	Visualisation and navigation in 3D environments . . . . .	166
8.1.4	3D analyses and 3D editing . . . . .	168
8.2	Accessing a geo-DBMS with a CAD front-end . . . . .	168
8.3	Accessing a geo-DBMS with a GIS front-end . . . . .	173
8.4	Accessing a geo-DBMS using Web technology . . . . .	177
8.4.1	VRML and X3D . . . . .	177
8.4.2	Prototypes . . . . .	180
8.5	Conclusions . . . . .	186
<b>9</b>	<b>Integrating 2D parcels and 3D objects in one environment</b>	<b>189</b>
9.1	Absolute or relative coordinates . . . . .	190
9.2	Introduction of a case study . . . . .	191
9.2.1	Description of data sets . . . . .	191
9.2.2	Combining point heights and 3D objects . . . . .	192
9.2.3	Assigning height to parcels . . . . .	192
9.3	Integrated TINs of point heights and parcels . . . . .	195
9.3.1	Unconstrained TIN . . . . .	195
9.3.2	Constrained TIN . . . . .	197
9.3.3	Conforming TIN . . . . .	198
9.3.4	Refined constrained TIN . . . . .	200
9.4	Analysing and querying parcel surfaces . . . . .	202
9.5	Generalisation of the integrated TIN . . . . .	203
9.5.1	Detailed-to-coarse approach . . . . .	204
9.5.2	Coarse-to-detailed approach . . . . .	204
9.5.3	Integrated height and object generalisation . . . . .	204
9.6	Generalisation prototype . . . . .	206
9.7	Conclusions . . . . .	209
<b>III</b>	<b>Models for a 3D cadastre</b>	<b>211</b>
<b>10</b>	<b>Conceptual model for a 3D cadastre</b>	<b>213</b>

10.1	Introduction of possible solutions . . . . .	213
10.2	A 2D cadastre with 3D tags . . . . .	216
10.3	The hybrid approach . . . . .	217
10.3.1	Registration of 3D right-volumes . . . . .	217
10.3.2	Registration of 3D physical objects . . . . .	220
10.4	A full 3D cadastre . . . . .	222
10.4.1	Combined 2D/3D alternative . . . . .	222
10.4.2	Pure 3D cadastre . . . . .	224
10.5	Evaluating the conceptual models . . . . .	225
10.5.1	Solutions seen from a cadastral point of view . . . . .	225
10.5.2	Solutions seen from a technical point of view . . . . .	226
10.5.3	The optimal solution for a 3D cadastre . . . . .	228
10.6	Conclusions . . . . .	229
<b>11</b>	<b>Logical model for a 3D cadastre</b>	<b>231</b>
11.1	3D right-volumes in the DBMS . . . . .	232
11.1.1	Spatial data model . . . . .	232
11.1.2	Administrative data model . . . . .	234
11.1.3	Data collection . . . . .	236
11.1.4	Querying . . . . .	236
11.2	3D physical objects in the DBMS . . . . .	237
11.2.1	Spatial data model . . . . .	237
11.2.2	Administrative data model . . . . .	238
11.2.3	Data collection . . . . .	239
11.2.4	Fundamental issues when linking GIS and CAD . . . . .	241
11.2.5	Querying . . . . .	242
11.3	Volume parcels in the DBMS . . . . .	242
11.3.1	Spatial data model . . . . .	243
11.3.2	Administrative data model . . . . .	244
11.3.3	Data collection . . . . .	244
11.3.4	Querying . . . . .	245
11.4	Maintaining history in the 3D cadastre . . . . .	245

11.4.1	History for 3D right-volumes . . . . .	246
11.4.2	History for 3D physical objects . . . . .	246
11.4.3	History in a full 3D cadastre . . . . .	246
11.5	Conclusions . . . . .	247
<b>IV</b>	<b>Realisation of a 3D cadastre</b>	<b>249</b>
<b>12</b>	<b>Prototypes applied to case studies</b>	<b>251</b>
12.1	Prototypes of the hybrid cadastre . . . . .	252
12.1.1	Case study 1: Building complex in The Hague . . . . .	252
12.1.2	Case study 2: The Hague Central Station . . . . .	254
12.1.3	Case study 3: Apartment complex . . . . .	259
12.1.4	Case study 4: Railway tunnel in urban area . . . . .	261
12.1.5	Case study 5: Railway tunnel in rural area . . . . .	263
12.1.6	Evaluation of hybrid cadastre . . . . .	266
12.2	Prototype of the full 3D cadastre . . . . .	268
12.2.1	The Gabba Stadium in Queensland . . . . .	268
12.2.2	Evaluation of full 3D cadastre . . . . .	271
12.3	Conclusions . . . . .	274
<b>13</b>	<b>Summary, conclusions and further research</b>	<b>277</b>
13.1	Analysis of the background . . . . .	277
13.1.1	Current registration practise of 3D property units . . . . .	278
13.1.2	Cadastral and juridical constraints for a 3D cadastre . . . . .	280
13.1.3	Needs and requirements for a 3D cadastre . . . . .	281
13.2	Framework for modelling 2D and 3D situations . . . . .	282
13.2.1	2D and 3D geo-objects in geo-DBMS . . . . .	282
13.2.2	3D GIS . . . . .	284
13.2.3	Accessing spatial information organised in a DBMS . . . . .	284
13.2.4	2D parcels and 3D geo-objects in one 3D environment . . . . .	285
13.3	Models for a 3D cadastre . . . . .	286
13.3.1	Conceptual solutions for a 3D cadastre . . . . .	286
13.3.2	The optimal solution for a 3D cadastre . . . . .	287

13.4 Realisation of a 3D cadastre . . . . .	288
13.4.1 Full 3D cadastre . . . . .	288
13.4.2 Hybrid cadastre . . . . .	289
13.5 Future directions for a Dutch 3D cadastre . . . . .	291
13.6 Further research . . . . .	293
13.6.1 Institutional aspects of 3D cadastral registration . . . . .	293
13.6.2 Geo-Information Infrastructure . . . . .	293
13.6.3 3D in the new generation GIS architecture . . . . .	293
13.7 Main results of this thesis . . . . .	296
<b>Bibliography</b>	<b>297</b>
<b>A Visualising attributes in VRML</b>	<b>315</b>
<b>B XSLT stylesheet to transform XML to X3D</b>	<b>317</b>
<b>Nederlandse samenvatting</b>	<b>321</b>
<b>Curriculum Vitae</b>	<b>327</b>







# Chapter 1

## Introduction

During the last two centuries population density has increased considerably making land use more intense. This trend has caused a growing importance of ownership of land, which has changed the way humans relate to land. This changing relationship necessitated a system in which property to land is clearly and indisputably recorded. In this thesis such a system is referred to as a ‘cadastre’ although many systems with different names are instituted world-wide, which fulfil (more or less) similar tasks, such as cadastral registration, cadastral system, land registry, land registration, land administration, property register and land book.

No unique form of a cadastre exists. In [34] it was noted that:

“It is impossible to give a definition of a Cadastre which is both terse and comprehensive, but its distinctive character is readily recognized and may be expressed as the marriage of (a) technical record of the parcellation of the land through any given territory, usually represented on plans of suitable scale, with (b) authoritative documentary record, whether of a fiscal or proprietary nature or of the two combined, usually embodied in appropriate associated registers.”

In principle, this thesis follows the description of a Cadastre as it is given in the FIG (International Federation of Surveyors) Statement on the Cadastre [53]:

“Cadastre is normally a parcel based, and up-to-date land information system containing a record of interests in land (e.g. rights, restrictions and responsibilities). It usually includes a geometric description of land parcels linked to other records describing the nature of the interests, the ownership or control of those interests, and often the value of the parcel and its improvements. It may be established for fiscal purposes (e.g. valuation and equitable taxation), legal purposes (conveyancing), to assist in the management of land and land use (e.g. for planning and other administrative purposes), and enables sustainable development and environmental protection.”

Although the aim of this thesis is not to focus on one Cadastre in particular, the Dutch Cadastre, which will be described extensively in chapter 2 and 3, will be used as the basic starting point. In the Netherlands the Cadastre, which is the responsibility of the Netherlands' Cadastre and Land Registry Agency (Kadaster), comprises both the cadastral registration and the land registration. The land registration (in the Netherlands) is a Public Register in which documents describing interests in land are kept. In some countries the land registration refers to the ordered and recorded legal documents as in the Netherlands, also called a deed registration, while in other countries the land registration refers to a property register, also called a title registration.

The cadastral registration in the Netherlands is a record of the rights that are registered on land. In the cadastral registration essential information from documents recorded in the land registration is linked to a location (parcel). Cadastral registration (or cadastre) as used in this thesis refers to both the active process of registration and the result of registration (also called register).

Basic entities of the cadastral registration are 'real estate', 'real property' or 'property' and 'subject'. In general land and buildings on the land are referred to as real estate, while various rights associated with land are called real property (or property) [53]. The subjects are persons or organisations that are entitled to real estate through property rights.

Originally, cadastral registration was often introduced to assist in land taxation. Today cadastral registration also provides relevant information for land transactions and helps to improve the efficiency of those transactions and security of tenure in land in general. It provides governments at all levels with relevant information for taxation and regulation. Cadastral registration is increasingly used by both private and public sectors in land development, urban and rural planning, land management and environmental monitoring and is no longer related to cadastral surveying and mapping alone [53, 212].

To be able to meet all these requirements, the main tasks of current cadastres can be defined as:

- to register the legal status of and governmental restrictions on real estate: the persons who have interests in land; what the interests are (nature and duration of rights, restrictions and responsibilities); on what land the interests are established (information on parcels such as location, size, value);
- to provide information on the legal status of and governmental restrictions on real estate.

In order to perform these tasks adequately, cadastral registration needs to maintain correct and consistent information, consisting of a complete set of cadastral parcels as well as a record containing interests on the parcels. Moreover cadastral registration has to be organised in such a way that the legal status of real estate becomes clear when querying the cadastral registration.

Individualisation of property started originally with subdividing the surface into property units using 2D boundaries. For this reason the basic entity of current cadastral maps is the 'parcel', which makes the cadastral map a 2D map. To ensure completeness and consistency, 2D parcels may not overlap and gaps may not occur (forming a

planar partition). Although parcels are represented in 2D, someone with a right to a parcel always has been entitled to a space in 3D, i.e. a right of ownership on a parcel relates to a space in 3D that can be used by the owner and is not limited to just the flat parcel defined in 2D without any height or depth. If the right of ownership only applied to the surface, the use of the property would be impossible. Consequently, from a juridical point of view cadastral registration always has been 3D. The question can be posed if traditional cadastral registration, which is based on the concept of a 2D parcel, is adequate for registering all kinds of situations that occur in the modern world or does cadastral registration need to progress to a 3D approach.

The FIG Bathurst Declaration [55] concluded that “most land administration systems today are not adequate to cope with the increasingly complex range of rights, restrictions and responsibilities in relation to land”. Since many existing cadastres are still based on a paradigm that has its origin centuries ago, this paradigm needs to be reconsidered and adjusted to today’s world. This thesis reconsiders the central paradigm of cadastral registration with respect to the issue of dimensions (2D and 3D).

This chapter presents the topic of this thesis and sets the outlines of the research described in this thesis. The chapter starts with a description of the need for a 3D cadastre (section 1.1). In section 1.2 the scope of this research is presented, while in section 1.3 the research objectives and the research methods that were used to reach the objectives of this research are described. Related research to this thesis is presented in section 1.4. The contribution of this work is described in section 1.5. This chapter ends with an overview of this thesis.

## 1.1 Need for a 3D cadastre

Pressure on land in urban areas and especially their business centres has led to overlapping and interlocking constructions (see figure 1.1). Even when the creation of property rights to match these developments is available within existing legislation, describing and depicting them in the cadastral registration poses a challenge. This is not surprising when looking at the FIG description of a Cadastre in which the parcel is the basic entity. The challenge is how to register overlapping and interlocking constructions when projected on the surface in a cadastral registration that registers information on 2D parcels. Although property has been located on top of each other for many years, it is only recently that the question has been raised as to whether cadastral registration should be extended into the third dimension. The growing interest for 3D cadastral registration is caused by a number of factors:

- a considerable increase in (private) property values;
- the number of tunnels, cables and pipelines (water, electricity, sewage, telephone, TV cables), underground parking places, shopping malls, buildings above roads/railways and other cases of multilevel buildings has grown considerably in the last forty years;
- an upcoming 3D approach in other domains (3D GIS (Geographical Information Systems), 3D planning) which makes a 3D approach of cadastral registration technologically realisable.



(a) Underground metro, Rotterdam, the Netherlands



(b) Subsurface shopping mall, Rotterdam, the Netherlands



(c) Business district La Defense in Paris, a road and a metro in the subsurface intersect buildings and plazas

Figure 1.1: *Examples of complex property situations.*

The core terms used in this thesis are 3D cadastre, 3D property unit, 3D (property) situation and parcel. A **3D cadastre** is a cadastre which registers and gives insight into rights and restrictions not (only) on parcels but on 3D property units. A **3D property unit**, also abbreviated to ‘3D property’ in this thesis, is that (bounded) amount of space to which a person is entitled by means of real rights. In fact the traditional parcel, with only one person using the parcel, is also a 3D property unit (often not explicitly bounded). However this has never caused any problems with

respect to the third dimension, since current cadastral registration is adequate to give insight into these traditional property situations. The problems arise in 3D property situations.

**3D property situations** (in this thesis also abbreviated to ‘3D situations’) refer to situations in which different property units (with possibly different types of land use) are located on top of each other or constructed in even more complex structures, i.e. interlocking one another (see figure 1.2).

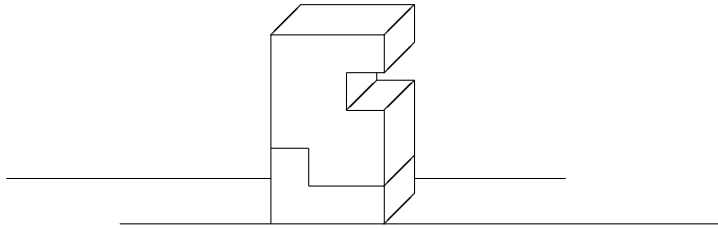

Figure 1.2: *Example of 3D property situation.*

In this thesis 3D property situations are also referred to as **stratified properties**. In 3D property situations several users are using an amount of space (volume), which is bounded in three dimensions. These volumes are positioned on top of each other, either all within one base parcel (the volumes are located in the same parcel column defined by the boundaries on the surface) or crossing base parcel boundaries. Real rights are established to entitle the different persons to the different volumes. A **parcel** is a separated piece of land, to which a person (or persons) is (are) entitled with a real right, such as right of ownership. Although, the ownership of land is not explicitly bounded in the third dimension, in most countries the ownership reaches as far as the owner has possible interest, while other persons are allowed to use space above and below a parcel as long as the user cannot reasonably object to this use (see figure 1.3).

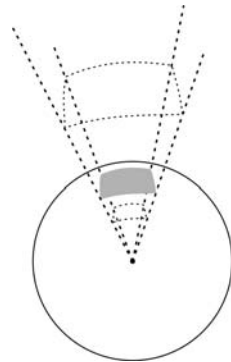

Figure 1.3: *An illustration of the spatial extent of the right of ownership to a parcel.*

Consequently, the geological subsurface may be very important for the factual demarcation of the third dimension of ownership. In areas with a solid geological subsurface, e.g. in most Scandinavian countries, a tunnel twenty-five meters below the surface will not cause any inconvenience to the owner of the surface parcel. Therefore such a construction may be allowed according to the concept of the right of ownership, while in countries with a ‘soft’ subsurface the space below the surface may be of much more interest for the owner of the surface parcel since subsurface activity may damage surface property.

To register 3D property situations in current cadastres, the legal status of 3D situations has to be translated in such a way that it can be registered in the current cadastral registration (see figure 1.4).

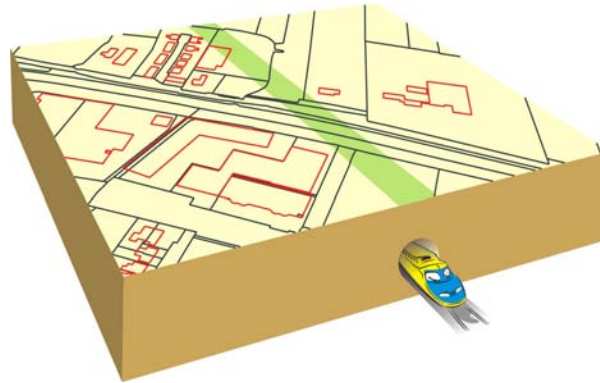

Figure 1.4: *How to register 3D situations in a 2D cadastral registration?*

FIG Commission 7 (Cadastré and Land Management) produced a vision of where cadastral registrations might be in 2014 taking current trends into account, such as the changing relationship of humankind to land, the changing role of governments in society, the impact of technology on cadastral reform, the changing role of surveyors in society and the growing role of the private sector in the operation of the cadastre [54]. The study resulted in the following six statements on Cadastre 2014 based on a four-year process involving input from many countries world-wide:

- Cadastre 2014 will show the complete legal situation of land, including public rights and restrictions.
- The separation between ‘maps’ and ‘registers’ will be abolished.
- Cadastral modelling will take over cadastral mapping.
- Paper-and-pencil cadastre will disappear.
- Cadastre 2014 will be highly privatised and public and private sector will work closely together.
- Cadastre 2014 will be cost recovering.

Although the statement on Cadastre 2014 does not mention 3D cadastre explicitly, the report emphasises that cadastres in the future will no longer be based on or restricted to (2D) cadastral maps. Future cadastres will show the complete (thus also in

all dimensions) legal situation of land, including public rights and restrictions. Also demands from practise will get growing influence on cadastral registration in the future. These aspects motivate the study of the 3D issues of cadastral registration in a broad, integrated view. The result of such a broad integrated approach is that all rights, restrictions and responsibilities related to land, often overlapping, are considered. This include many more aspects than would traditionally be of interest of and be recorded in a cadastral registration [212].

The Netherlands' Kadaster has the responsibility for cadastral registration in the Netherlands. Until now the Netherlands' Kadaster has been able to register 3D situations within current registration possibilities. Are these registration-methods sufficient to fulfil the main tasks of a cadastral registration, i.e. to *register* the legal status of real estate and to *provide* insight into the legal status of real estate?

Since a few situations have occurred (and more are expected in the future) which could not be registered unambiguously and clearly in the cadastral registration, the discussion started on what to do with 3D situations. To support this discussion the Netherlands' Kadaster and the TU Delft took the initiative to start a research on 3D cadastral registration to study the needs, constraints and possibilities of a 3D cadastre. This thesis is the result of this research which was carried out at TU Delft in collaboration with the Netherlands' Kadaster.

## 1.2 Research scope

The scope of research on 3D cadastre is demarcated by three frameworks which determine the needs, constraints and possibilities for 3D cadastral registration. These frameworks are linked to each other in a hierarchical order:

- Juridical framework: how can the legal status of stratified properties be established? how to establish property boundaries other than traditional 2D parcel boundaries? what rights can be used and how can these rights be used?
- Cadastral framework: once the legal status of property in 3D situations has been established and described in deeds and in field works that are archived in the land registration, the next issues are how to register the rights and restrictions to property (bounded in three dimesnions) in the cadastral registration and how to provide information on the legal status of 3D property situations?
- Technical framework: what system architecture (computer hardware, software, data structures) is needed to support cadastral registration in 3D situations? what architecture is technologically possible?

This thesis will focus mainly on the cadastral and technical framework.

### 1.2.1 Topics within the scope of this thesis

Several fundamental considerations outline the scope of this thesis as follows:

- Current cadastral registration (in combination with current land registration) serves its purposes well in most (2D) situations and it has a good foundation

in today's society based on long history. It is therefore not feasible to think of a 3D cadastre totally outside the current juridical and cadastral framework. This does not mean that (feasible) adjustments in the framework cannot lead to improvements. Therefore the precondition of this thesis is to start with the current cadastral registration and to see where this registration suffices and where it needs improvements (extensions) in case of 3D situations. This precondition imposes special demands on this research to 3D cadastre, since the 3D cadastre should fit to some extent within the current juridical, cadastral and technical framework.

- Although generalities on 3D registration are addressed, this thesis focuses on cadastral registration in particular.
- Disseminating information via the Internet is important in today's society. Therefore the cadastral registration that is considered should fit in a Geo-Information Infrastructure (GII).
- This thesis focuses in the first place on cadastral registration in the Netherlands. Since cadastral registration abroad has similar fundamental characteristics, the main conclusions drawn in this thesis are extendible in (a limited way) to other cadastral registrations. However, it should be noted that many minor differences are present between cadastral registrations in different countries due to different legislation and different implementation history.
- Cadastral registrations in other countries will be considered in order to examine the need for 3D registration in other countries, to see if and how other countries solve the problem of 3D cadastral registration and to come to more general (not only valid for the Dutch situation) conclusions.
- Both cadastral and technical issues will be addressed. Cadastral issues deal with the main tasks of the cadastre in 3D situations and technical issues determine how these cadastral issues can be implemented.
- Since a DBMS (DataBase Management System) is an essential part of the architecture that is capable of maintaining large amounts of (spatial) data such as in cadastral registration, a main issue of this thesis is how to model 3D geo-objects (topologically and geometrically) in a DBMS.
- The cadastral registration must provide access to a wide spectrum of users (citizens, real estate agents, notaries, GIS/CAD specialists). Therefore another major issue is how the cadastral DBMS can be made accessible for users.
- With respect to 3D GIS, efficient methods for geometric construction, data structuring, organisation of 2D and 3D data in one environment, database creation and updating have yet to be developed. This thesis will give considerations and preliminary solutions for these issues.
- The main focus of this thesis is to give technical solutions and technical recommendations to implement a 3D cadastre. For this purpose the needs for a 3D cadastre in general are studied and translated into technical needs. Current (commercially available) techniques are tested to evaluate if they are able to meet these needs. If fundamental solutions are not provided by commercially available techniques, concepts are designed which are tested by translating the concepts into prototypes.



## 1.2.2 Topics outside the scope of this thesis

Topics that are not within the scope of this thesis can be described as:

- It is not the aim of this thesis to provide solutions for 3D registration for any cadastre outside the Netherlands, although cadastral registries in other countries can use the findings of this thesis that address general issues of cadastral registration in 3D situations.
- Juridical issues will be addressed in this thesis, but will be merely used as preconditions. It is not the aim of this thesis to give recommendations on (major) changes of the legal system in the Netherlands. However the experiences and findings in this thesis may lead to recommendations for developments and further research on juridical issues.
- This thesis does not intend to develop an operational 3D cadastral registration, since this is not considered feasible at this stage, in which many issues still need to be resolved and in which choices need to be made on where to go to. This thesis firstly aims at a clear definition of the problem, a development of concepts and validation and evaluation of the concepts by prototyping key aspects.
- Functionality of 3D cadastral registration is the main topic of this research. Performance testing and benchmarking with respect to 3D cadastral registration or other information systems are therefore not part of this research.
- This thesis addresses cadastral registration in particular and will therefore not address topographical or other registrations.

## 1.3 Research approach

In this section the research objectives and the research methods that were used to achieve these objectives are explained.

### 1.3.1 Research objectives

The main objective of this thesis is to answer the question how to record 3D situations in cadastral registration in order to improve insight into 3D situations. The emphasis of this thesis is on the technical aspects of cadastral registration. To realise this objective, this thesis concentrates on four different topics:

- **Analysis of the background.** This part focuses on identifying problems of current cadastral registration concerning 3D situations, both in the Netherlands and abroad, in order to get insight into the needs and requirements for 3D cadastral registration and in order to structure the national and international discussion on 3D cadastre.
- **Framework for modelling 2D and 3D situations.** In this part techniques are explored that are needed for a 3D cadastre:
  - How to model 2D and 3D geo-objects in a DBMS which is the core of the new generation GIS architecture?
  - What is the state-of-the-art of 3D GIS?

- How to access and analyse 3D geo-objects organised in a geo-DBMS?
- How to combine 2D parcels and 3D geo-objects in one environment?
- **Models for a 3D cadastre.** In this part conceptual models are designed based on current registration and based on available techniques in order to improve 3D cadastral registration. Also considerations are given for translating the conceptual models of a 3D cadastre into logical models.
- **Realisation of a 3D cadastre.** The proposed conceptual models are evaluated by translating conceptual alternatives into prototype implementations using techniques explored and developed as part of this thesis and by performing functional tests. Performance tests are not part of this thesis.

### 1.3.2 Research methods

To answer the research questions, the following research methods are used.

#### **Analysis of the background**

“What are the actual needs for 3D registration?” is the first important topic of this research. To answer this question a literature study will be carried out to come to a list of types of cadastral recordings with a possible 3D component. To conclude on the actual complications of current registration of 3D situations in the Netherlands, six (national) case-studies will be carried out. To get insight also into the needs for cadastral registration abroad, the question will be addressed “how are 3D situations internationally registered and do other countries meet the same problems?” To answer these questions an international workshop on 3D cadastres was organised. Knowledge obtained during this workshop supplemented with literature study will be presented. During a working visit to Aalborg, Denmark, the Danish cadastral registration in case of 3D situations has been examined. In collaboration with Queensland Government, Australia, also a case study in Brisbane, Queensland has been carried out. The results of both case studies will be described.

#### **Framework for modelling 2D and 3D situations**

How geometrical primitives and topology structure can be modelled both in 2D and 3D in a DBMS and what is the current state-of-the-art of 3D GIS are the next topics. The description of the state-of-the-art of 3D GIS is a result of literature study. Answer to the first question is basically a result of carrying out experiments with current DBMSs and with new developments designed and implemented as part of this research. The same approach will be followed to find out how 3D geo-information stored in a geo-DBMS can be accessed by front-ends. Experiments will also be carried out to explore fundamental issues of combining 2D parcels and 3D geo-objects in one environment.

#### **Models for a 3D cadastre.**

The main question in this research is how can current cadastral registration be improved in case of 3D situations? To answer this question conceptual modelling for 3D cadastre will be carried out based on the findings of the analysis of the background and of the analysis of the technological possibilities of modelling 2D and 3D situations.

#### **Realisation of a 3D cadastre.**

The conceptual models will be translated into prototype implementations. In experiments in which the prototype implementations will be applied to the case studies,

the conceptual models for a 3D cadastre will be evaluated. The experiments with the prototypes will also lead to conclusions on how to realise an effective 3D cadastre.

## 1.4 Previous and related research

Related research to this thesis, which focuses on cadastral and technical aspects of a 3D cadastre, can be divided into research on 3D cadastral registration and research on 3D tools and 3D modelling.

### 1.4.1 Related research on 3D cadastres

Israel is one of the countries which faces high pressure on the use of land. This has promoted developments for a 3D cadastre. Therefore in Israel for the past five years several studies have started on 3D cadastres [9, 57, 58, 63, 64] (see also section 4.8).

Mid European countries such as Ukraine [116], Hungary [161], Czech Republic [81] and Slovenia [170] are in the phase of examining the current cadastre for potential registration of 3D property units, including apartments.

International marine cadastres traditionally have a 3D approach, as the use of the marine environment is volumetric by nature and involves rights to the surface, water column, seabed and subsoil. The University of New Brunswick (Canada), Department of Geodesy and Geomatics Engineering is developing a 3D marine cadastre to support effective and efficient decision making associated with marine governance [126, 232]. In [60] the framework issues are discussed that must be considered in the development of marine cadastral data and the use of these data in a marine information system for the United States. In this discussion 3D aspects are also addressed.

Some other countries and states have already solved part of 3D cadastral registration (Norway, Sweden, Queensland and British Columbia), as will be seen from the study on 3D cadastral registration abroad (chapter 4).

### 1.4.2 Related research on 3D tools and 3D modelling

3D registration deals with maintaining spatial and non-spatial information on 3D objects, which are core topics of 3D GIS. Therefore developments in 3D GIS are important when examining a 3D registration.

The main characteristic of researches on 3D models intended for 3D GIS and 3D geo-DBMSs, is that they are extensive and that the results of these researches are fragmented. Examples of 3D models intended for 3D GIS and 3D geo-DBMSs are [56, 94, 119, 168, 169, 184]. Implementations of 3D models in user-developed systems can be found in [19, 147, 181, 227].

Research on spatial querying and 3D visualisation of geo-objects using Web technologies has resulted in several prototype systems [13, 31, 35, 96, 104, 240]. Research on spatial querying and 3D visualisation of geo-objects organised in a DBMS has not yet

resulted in any publications, apart from publications that were written as part of this research.

Since developments in 3D GIS are important when studying the possibilities for a 3D cadastre, a section is included in this thesis which describes the current state-of-the-art of 3D GIS (section 8.1).

## 1.5 Contribution of the work

The main contributions of this work can be summarised as follows:

- Enabling a complex registration addresses many issues in a variety of disciplines (technical, cadastral, juridical, organisational). This thesis is the first extensive research on 3D cadastres in which the problem of registration in complex situations has been studied using an integrated approach. Therefore this thesis has strong explorative characteristics resulting in a clear analysis as well as a distinct definition of the essential problems of registering 3D situations in current cadastres taking all involved disciplines into account.
- This thesis structures the national and international discussion on the need for 3D cadastre by providing a universal overview of the basic and fundamental needs for a 3D cadastre, considered from different points of view (juridical, cadastral, technical) and by providing insight into country-specific aspects which influence the need for and possibilities of 3D cadastral registration.
- This thesis gives solution-directions for a 3D cadastre. Several models for a 3D cadastre will be introduced and translated into prototype implementations. Experience with the prototypes will result in concrete recommendations. Based on these recommendations, decision-makers will be able to base choices on if and how to implement a 3D registration on fundamental considerations.
- In technical respect, the outcomes of this research contribute to 3D GIS in general, i.e. how to model and maintain 3D geo-objects in a DBMS, how to access and query these objects by front-ends and how to combine 3D geo-objects and 2D geo-objects in one 3D environment. With respect to improving 3D GIS functionalities, an extension of a geo-DBMS has been built to support 3D primitives. Also a study was carried out to generate an appropriate integrated height model in a TIN (Triangular Irregular Network) structure based on both the 2D planar partition of parcels and point heights.
- This work contributes to supporting the demand for 3D geo-information in today's society in general. Other organisations responsible for (spatial) registrations and for spatial data sets can use the outcomes of this work to see the possibilities and constraints to extend their systems into the third dimension (e.g. registrations for cultural heritage, for buildings, for zoning plans, for cables and pipelines, and databases of topographical mapping agencies).

## 1.6 Organisation of the thesis

Chapter 1 (this chapter) presents the need for a 3D cadastre, specifies the objectives, the scope and the contributions of this research and describes related research. The main body of this thesis, apart from the introduction (chapter 1) and conclusions (chapter 13), is divided into four major parts corresponding with the four main research topics of this thesis as described in section 1.3.1.

1. Part I: Analysis of the background (chapters 2, 3, 4, 5)
2. Part II: Framework for modelling 2D and 3D situations (chapters 6, 7, 8 and 9)
3. Part III: Models for a 3D cadastre (chapters 10 and 11)
4. Part IV: Realisation of a 3D cadastre (chapter 12)

Readers who are familiar with cadastral registration with respect to the 3D component and are less interested in a detailed study on needs for 3D cadastral registration may skip part I. Readers who are familiar with spatial modelling in DBMSs both in 2D and 3D and with accessing this information with front-ends or the reader who is not interested in technical issues of 3D cadastral registration may skip part II. The introduction and evaluation of new conceptual data models for 3D cadastral registration is described in part III and part IV.

Chapter 2 gives an overview of the types of cadastral recordings in the Netherlands with a potential 3D component. The aim of this chapter is to get a clear view on the cadastral domain on which the 3D cadastral research should focus. For what types of cadastral recordings should a 3D approach of registration be considered? Cadastral registration is in this chapter subdivided into cadastral registration according to Private Law and cadastral registration according to Public Law. The chapter starts with a description of common alternatives of cadastral registrations, followed with an introduction into the cadastral registration of the Netherlands' Kadaster.

Chapter 3 describes the results of six case studies which were carried out to indicate the complexities of registering 3D situations within the current Dutch cadastral registration. Three case studies were selected based on multilevel building complexes in urban areas that interact with other land use, such as roads and railways. The other three case studies were selected based on subsurface infrastructure objects. The basic purpose of cadastral registration of building complexes is to provide insight into the property units within the building complex. The basic purpose of cadastral registration of infrastructure objects is to register the person who is responsible for the infrastructure object. The case studies resulted in findings which describe the limitations of current cadastral registration and the actual needs for a 3D cadastre.

Chapter 4 presents the results of a study abroad. To see if this thesis can learn from international developments and to place this research in an international context, countries abroad were examined. Six countries and states in which the discussion on 3D cadastre has already started or that have solved (part) of the problem of 3D cadastral registration were examined: Denmark, Norway, Sweden, Queensland (Australia), British Colombia (Canada), and Israel. The results of the study abroad are reported in chapter 4.

Chapter 5 elaborates on the needs and opportunities for a 3D cadastre based on the findings described in chapters 2, 3 and 4.

Chapter 6 aims at clarifying some basic terms and concepts concerning spatial data modelling that are used and applied in this thesis. Data models and in specific characteristics of spatial models are described, followed by a description of the basic phases of data modelling. UML (Unified Modelling Language) is used in this thesis to describe the data models. The basic characteristics of UML are explained. How the relationship between spatial data modelling and DBMSs has evolved is also discussed. The chapter ends with a description of standardisation initiatives.

Chapter 7 discusses the state-of-the-art of DBMSs in the new generation GIS architecture: how spatial objects can be maintained in a geo-DBMS using both a structure of geometrical primitives and a topological structure. Spatial analyses on both structures are considered as well. The chapter also contains a section describing the implementation of a 3D primitive in a DBMS, a study which was carried out as part of this thesis.

As described in chapter 7, geo-DBMSs are the core of the new generation GIS architecture. 3D GIS is a basic instrument to deal with 3D geo-information in general. Therefore the state-of-the-art of 3D GIS aspects other than geo-DBMSs is discussed in chapter 8. Chapter 8 reports also the results of a research that was carried out to access (query and visualise) 3D objects that are organised in a geo-DBMS. For this research three front-ends were studied: a CAD oriented system, a GIS system and a self-implemented system using Web based techniques.

Chapter 9 deals with the fundamental issue of combining 3D geo-objects (3D cadastral objects) and 2D geo-data (parcels) into one system: how to relate the two data sets in space. A case study was carried out to show possibilities and problems of integrating a 3D geo-object (pipeline) and surface parcels in one environment. TINs, representing integrated height models of point heights and parcels, that were created during this case study, are described together with their data structure and their results. The TINs are inserted in the DBMS which makes it possible to perform spatial analyses on height surfaces of (individual) parcels. In order to obtain a more effective height model, a generalisation method was developed and is described in this chapter. This method has partly been implemented in a prototype. The prototype selects only the significant TIN-nodes while removing the non-significant TIN-nodes. Results of the prototype are also reported.

Chapter 10 introduces three concepts for a 3D cadastre, each with different alternatives, which were designed as part of this research. Based on both cadastral and technical considerations two of these three concepts were selected as most optimal solution for a 3D cadastre: a hybrid 3D cadastre (with two alternatives) and a full 3D cadastre (only one alternative).

Chapter 11 considers issues that come with translating the conceptual models that were introduced in chapter 10 into logical models: issues concerning the spatial data model, the administrative data model, as well as the process of data collection to obtain data that can be inserted into the spatial data models. Also 4D requirements of a 3D cadastre that need to be taken into account in the phase of logical modelling are considered.

Chapter 12 evaluates the proposed conceptual models from chapter 10 by applying prototypes, which contain the key aspects of the conceptual and logical models, to the case studies introduced in chapter 3 and 4.

Chapter 13 summarises this thesis and concludes the major findings of this research. In this chapter it is concluded that a full 3D cadastre is a feasible solution to solve 3D cadastral issues at a fundamental level, taking juridical, cadastral as well as technical aspects into account and that such a cadastre is realisable. The chapter also contains recommendations for future research.





## Part I

# Analysis of the background



## Chapter 2

# Current cadastral registration of 3D situations in the Netherlands

Multilevel use of land is not new. In the Middle Ages cellars below roads along wharfs (*werfkelders*) already existed in Dutch cities (see figure 2.1), and for more than a century stores, workplaces, pubs and even houses, have been situated under railway viaducts. How are 3D situations like this recorded in the current cadastral registration; what are the complications of these recordings, and why has the question for a 3D cadastre only been raised recently? To answer these questions, first an inventory has been made of current cadastral recordings of the Netherlands' Kadaster in which the 3D aspects of registration are considered. Results of this inventory will be described in this chapter. The aim of the inventory is to get a clear view on the cadastral domain on which the 3D cadastral research should focus.

Many types of cadastres exist based on country specific characteristics such as local cultural heritage, physical geography, land use, technology etc. The type of a cadastre (organisation, technical implementation etc.) influences needs as well as possibilities for 3D registration. Therefore this chapter starts with a short introduction of different classifications of cadastral registrations (section 2.1).

After an introduction into the registration of the Netherlands' Kadaster (2.2), the types of cadastral recordings according to Dutch Private Law for which 3D aspects might be relevant are described (2.3), followed by a description of types of 3D cadastral recordings according to Dutch Public Law (2.4). Section 2.5 describes other aspects of cadastral registration in the Netherlands which are relevant for this thesis. The chapter ends with conclusions.



Figure 2.1: *Cellars below roads in Utrecht.*

## 2.1 Different types of cadastral registrations

Traditionally, cadastral registrations consisted of a set of cadastral maps containing cadastral parcels with (mostly) unique parcel numbers and a paper archive in which property information on parcels was maintained. Since the end of the last century cadastral registrations in developed countries have been converted from analogue cadastral registrations into digital registrations. Spatial information on parcels is no longer maintained on paper maps but in GIS and CAD or even more sophisticatedly in spatial DBMSs. Information on property and other information that is nowadays registered in cadastral registrations (mortgage, soil pollutions, monuments) is no longer (only) maintained in paper archives but in cadastral databases. A link is maintained between the digital cadastral map and the cadastral administrative database. The link provides the possibility to query the spatial part and administrative part of cadastral registration and combine the results. In more advanced systems it is possible to query the spatial and administrative part of cadastral registration in one integrated environment.

Cadastrals can be classified in many ways, based on different criteria e.g. as proposed in [53]:

- primary function (e.g. supporting taxation, conveyancing, land distribution, or multipurpose land management activities);
- the types of rights recorded (e.g. private ownership, use rights, mineral leases, public law restrictions);
- the degree of responsibility in ensuring the accuracy and reliability of the data (e.g. complete state mandate, shared public and private responsibility);
- location and jurisdiction (e.g. urban and rural cadastres; centralised and decentralised cadastres);

- the many ways in which information about the parcels is collected (e.g. ground surveys tied to geodetic control, uncoordinated ground surveys and measurements, aerial photography, digitising existing historical records, etc).

All these factors determine the required resolution and scale of spatial data, the type and characteristics of data recorded in both thematic and geometrical attributes, and the organisational and professional responsibility for managing the data. Consequently, these factors also influence the need for 3D cadastral registration in a specific country and how the 3D issue is or will be approached.

In [236] and [237] different classifications are proposed to describe most common alternatives for cadastral (and land) registration. These classifications are based on the most essential criteria. Since these classifications form a good overview of the differences that may exist between different cadastral registrations, the classifications are described below.

#### **Deed versus title registration**

The classification of deed registration versus title registration, is the most often used classification. The most basic difference is that “deed registration is concerned with the registration of the legal fact itself and title registration with the legal consequence of the fact” [73]. However, mostly also other factors are taken into account when distinguishing between titles and deeds. The complete definition given in [73] is:

**Deed registration** A deed registration means that the deed itself, being a document, which describes an isolated transaction, is registered. This deed is evidence that a particular transaction took place, but is in principle not itself proof of the legal rights of the involved parties and, consequently, it is not evidence of its quality. Thus before any dealing can be safely effected, the ostensible owner must trace his ownership back to a good root of title.

**Title registration** A title registration means that it is not the deed describing the transfer of rights that is registered but the legal consequence of that transaction, i.e. the right itself (title). So the right itself together with the name of the rightful claimant and the object of that right with its restrictions and charges are registered. With this registration the title or right is created.

In the deed registrations, (which is common in most of the countries in Western Europe and many of their former colonies, the United States and countries in Latin America falling under Spanish/Portuguese law) the documents filed in the land registration are the evidence of title. The registration itself does not prove title: it only records a transaction between parties. In the title registrations (common in the United Kingdom, most of the countries of the Commonwealth and many countries in Central Europe), the register itself serves as the primary evidence. The title is constituted by registration. The registration of title enables a title to be ascertained as a fact. A title registration is an authoritative record kept in a public office. The register is maintained and warranted by the state.

As concluded in [237] the debate on ‘title versus deeds’ is complicated, since no distinct definition can be given. Also technological developments have provided the

instruments to decrease the former differences. Generally speaking, there are examples of good and bad title registrations and good and bad deed registrations. The real protection of land ownership is more dependent on the quality of information in the land and cadastral registration and not on the type of land and cadastral registration. In order to avoid making the 3D cadastral issue more complicated than necessary, this debate will be left out of this thesis. The classification based on titles versus deeds was mentioned here for completeness.

### **A centralised or decentralised cadastral registration**

In every country the protection of rights to land is considered a governmental task. However, not every country has a strong national authority. In some cases financial and technical responsibility lies at regional or even local level. Therefore cadastral registration may be the responsibility of local governments while in others it is a state or national responsibility. Apart from the question of whether local or national government is responsible for cadastral registration, cadastral registration can be carried out at different levels (in a central database, in regional or local databases or at regional and local level while a centralised database is maintained). The question of the existence of a centralised cadastral database is dependent on three main aspects:

- State of the art of database technology. A cadastral registration consists of an administrative and a spatial part mostly maintained in databases. For decentralised systems many databases have to be maintained, which should be avoided since databases (especially the spatial part) requires expensive equipment and expertise. Technical development on the area of databases also motivates concentration at national level, since DBMS technology favours an approach of one centralised DBMS in which all objects of interest for a specific application are maintained. A centralised DBMS is easier and cheaper to manage.
- State of the art of telecommunication by mobile telephones and Internet facilities. Decentralised systems were set up to bring cadastral information closer to end-users. With modern technologies of telecommunication and Internet it is no longer as relevant where cadastral information is maintained.
- The question whether to have a centralised or a decentralised cadastral system is dependent on the way a specific country organises its whole administration, since a cadastral system is part of the administration of a country.

The Ministry responsible for the cadastral registration also differs per country:

- Ministry of Finance. This is mostly the case when a cadastral registration was originally started as a fiscal cadastre.
- Ministry of Agriculture. In some countries this Ministry only has the responsibility for rural activities (land consolidation), while in other countries this Ministry has the responsibility for the whole national cadastre (e.g. Hungary).
- Ministry of Housing or the Ministry of Public Works. This Ministry has the responsibility for the urban cadastre.
- Ministry of Justice. The Ministry of Justice has the responsibility for cadastral registration since land registration originally has a legal nature. Registration takes place in local courts (Austria and Romania).
- Ministry of Interior (Poland).
- A separate authority is responsible to prevent the discussion of the ministerial responsibility.

At what authority level and by which Ministry the 3D issue of cadastral registration is approached depends on the organisation of cadastral registration.

#### **Land registration with separate or integrated cadastre**

In several countries land registration and cadastral registration are handled by one organisation. This makes it easier to make the contents of both registrations identical. In other countries the separation of land registration and cadastral registration has a historical background (e.g. Denmark, Austria, Bulgaria and Poland). In these countries the land registration and cadastral registration are also mostly the responsibility of different Ministries. Land registration has generally been the mandate of the courts and the legal profession. Mapping, parcel boundary delimitation and maintenance of parcel data for fiscal, land use control, and land redistribution purposes is traditionally the responsibility of the surveying profession [53]. In case of manual registrations, it is hard to keep two separated registrations up-to-date and identical. In an integrated cadastre, land registration and cadastral registration are better geared to one other. Therefore, improvement of information supply in case of 3D situations can be achieved by the combined efforts of both land registration and cadastral registration. In a separated system it will be harder to join the two registrations in order to achieve one common goal (i.e. improve insight in case of 3D situations). This goal cannot be achieved without a tight collaboration between land registration and cadastral registration.

#### **Fiscal or legal cadastre**

Very often cadastral registrations started as a fiscal cadastre for taxation, e.g. the ‘Napoleontic Cadastre’. Such cadastres were based on a full survey of the ownership parcels. After a few decades such fiscal cadastres were changed into legal cadastres. In some countries there are still problems with the old cadastral maps. For example in the Ardennes, in Belgium, the cadastral maps give the real area of the surface of land parcels that are located on the slope of hills. The transfer of this information to a cadastral map, which is a projection of the terrain onto a horizontal plane, is so expensive that a digital map in this country was never produced (note that this is a nice example of a 3D cadastral aspect). A fiscal cadastre is less complex than a legal cadastre. In the case of a fiscal cadastre a cadastre can be less accurate in maintaining geometry and other attributes if the property tax is based on valuation. In addition a fiscal cadastre needs an up-date every year (when following a yearly tax cycle), whereas a legal cadastre needs an up-date every day. A legal cadastre will therefore impose more conditions on the availability of information in case of 3D situations.

#### **General or fixed boundaries**

A parcel is defined by indicating its boundaries. General boundaries are boundaries which have to be visible features on the landscape. These features are supposed to coincide with the position of boundaries and can be mapped relatively easily because the features are easy to measure with surveying, with aerial photogrammetry or from topographic maps. Although these boundaries do not indicate the exact location of parcel boundaries, the parcel is reasonably defined and can be identified beyond doubt. In case of fixed boundaries all parties involved have to fully agree on the exact position of each boundary point (after which the position of parcel boundaries can be marked on the terrain). The demarcation, measuring and registration of fixed

boundaries requires more time. Once 3D property units are defined within cadastral registration, the type of boundaries within the specific cadastral registration (general or fixed) will impose requirements for the boundaries demarcating 3D property units.

#### **Financed by government or cost-recovering**

In general the maintenance of the cadastral registration is a regular task of the government which means that normal cadastral activities are generally financed by the government. Cadastral registrations generate income from fees for registration of transactions, mortgages etc. and supply of information. The income generated by the cadastre goes straight to the State Treasury when the cadastre is a regular task of the national government. Consequently there is no link between the income and the expenses of the cadastral registration. The motivation to take care of user requirements, e.g. to establish a 3D cadastre, is therefore limited [236] unless it is imposed by the government. The alternative is that a cadastre is an independent organisation which is responsible for its own income and expenses forcing them to listen to changing user requirements.

## **2.2 The Netherlands' Kadaster**

In this section the Netherlands' Kadaster and the basic principles of Dutch cadastral registration are described.

### **2.2.1 Organisation of the Netherlands' Kadaster**

The Netherlands has a deed registration, which is maintained together with the cadastral registration by one organisation: the Netherlands' Kadaster. The national government (Ministry of Spatial planning, Housing and the Environment) is responsible for the Cadastre, although the Kadaster is an independent organisation since 1994. The organisation is financially fully self-supporting. Till recently the cadastral registration was maintained at regional level, but is now organised at one location, although the actual registration is still performed at fifteen regional offices. The Netherlands' Kadaster serves both fiscal and legal purposes. The Kadaster also supports land management by registering legal restrictions dictated by Public Law such as soil pollution and monuments apart from real rights. Fixed boundaries are used in the Netherlands, which means that all persons involved have to fully agree on the location of parcel boundaries. Apart from the main cadastral tasks the Netherlands' Kadaster has the following responsibilities:

- consolidation of land;
- maintaining the Large Scale Map of the Netherlands (GBKN) together with other parties;
- maintaining the Dutch Geometric Infrastructure together with the Survey Department (NAP) from the Dutch Ministry of Transport, Public Works and Watermanagement;
- since January 2004 the Kadaster is responsible for the traditional tasks of the Dutch Topographic Service, since they merged with the Topographic Service.



### 2.2.2 Public Registers and cadastral registration

The Netherlands' Kadaster maintains the land registration, i.e. the Public Registers (*Openbare Registers*) [115]: a collection of notarial deeds creating or transferring real rights to land. These deeds have been (analogously) archived in chronological order. Since 1999 the deeds in the Public Registers are available in scanned format and will soon be available through the cadastral database.

The Netherlands' Kadaster also has the responsibility for the cadastral registration in the Netherlands comprising registration of parcel boundaries and registration of the legal status of parcels, which is a summary of the information described in deeds. The cadastral registration makes information in deeds (rights and restrictions) referring to individual parcels accessible. The Dutch cadastral registration consists of two parts [102]:

- a 2D geo-DBMS for maintaining the geometry and topology of parcels as well as streetnames, house numbers, parcel numbers and buildings for reference purposes called LKI (*Landmeetkundig Kartografisch Informatiesysteem*, 'Information system for Surveying and Mapping'). LKI also contains the Large Scale Map of the Netherlands. Both the cadastral map and the Large Scale Map can be generated out of the LKI database since the objects in the database contain a code specifying if the object is part of the specific map;
- an administrative DBMS for maintaining legal and other administrative data related to parcels as well as a registration of mortgages called AKR (*Automatisering Kadastrale Registratie*, 'Automated Cadastral Registration').

A link between the spatial and administrative database exists through the unique parcel number [102].

Recently the Netherlands' Kadaster has developed the Querytool by which the two databases can be queried in one integrated environment [138]. Another application launched by the Kadaster (Kadaster-online) makes both databases (spatial and administrative) accessible for specific purposes.

### 2.2.3 Cadastral model

The current administrative cadastral data model in the Netherlands, and also in most other countries, is based on three key types: real estate object, person (subject) and right or restriction. The UML class diagram of the data model is shown in figure 2.2 (see also [101]). Real estate objects are (part of) parcels and apartment rights (linked to a 'mother' parcel, not shown in figure 2.2). Persons are persons or organisations with rights on parcels. Beside rights, there can also be a 'restriction' relationship between a real estate object and a person, since a person can be the subject of a restriction, e.g. a holder of a pipeline for which a restriction has been established. Real estate objects and persons have n:m relationships via rights (and restrictions); a person can have rights related to more than one real estate object (e.g. a person owns three parcels) and one real estate object can be related to more than one person (e.g. one person is bare owner of a parcel and another person has the right of superficies on the parcel) [137]. Every person in the registration should be associated with at least

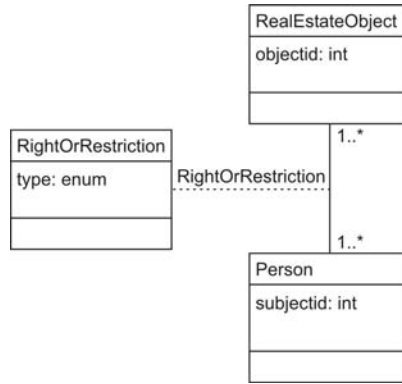

Figure 2.2: *The current administrative cadastral data model in a UML class diagram.*

one real estate object and vice versa; every real estate object should be associated with at least one person (indicated with the multiplicity of ‘1..\*’; for a description of UML see section 6.5).

## 2.2.4 Mapping real world objects

Parcels defined in 2D are the basis for cadastral registration. Constructions and infrastructure under or above the surface are not registering objects themselves. A building registration also does not exist in the Netherlands, although research has been carried out to set up such a registration in the future [92]. Therefore, the legal status of constructions above, on and under the surface is not registered on the construction itself. The legal status of the construction can be known from the rights that are registered on the surface parcel(s). The notary deed, which has led to registration, may be accompanied by an analogue drawing of the physical object but this is not obligatory. The inclusion of digital 2D and 3D drawings in the cadastral registration is not possible at the moment.

The Dutch cadastral geographical data set contains the boundaries of parcels and parcel numbers, outlines of buildings (for reference purposes), street names and house numbers. The outlines of real world objects can be incorporated in the topographic part of LKI (which is not part of the cadastral map). Examples of such real world objects are railways and since recently also transport systems and telecom-networks. Apart from the classification code, these lines are encoded with a visibility code. The visibility code indicates the visibility of the topographic line. A visibility code ‘2’ means ‘not visible from above’. Figure 2.3 shows part of the LKI database (the topographic part). In this figure a road (running from north-west to south-east) crosses a railway (running from south-west to north-east) with a viaduct (the road is below the railway). The road at the location of the viaduct is invisible from above. All lines encoded as ‘invisible from above’ are only drawn in the left figure in figure 2.3 and are omitted in the figure on the right. The mapping of underground features using a special classification and ‘invisible’ code is optional and therefore not required.

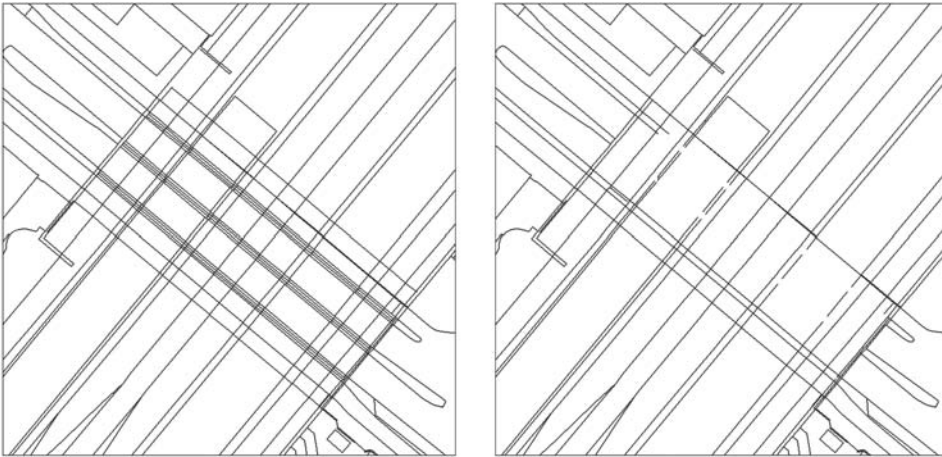

Figure 2.3: Lines encoded as ‘invisible’ in the topographic data set are not drawn in the map on the right.

## 2.3 3D registration and Private Law

Regarding Private Law, the main types of cadastral recordings with a 3D component are (the Dutch terms are added in *italic*, in brackets):

- right of ownership (*eigendomsrecht*) (section 2.3.1);
- limited ownership rights (*beperkte rechten*):
  - right of superficies (*opstalrecht*) (section 2.3.2);
  - right of long lease (*erfpacht*)(section 2.3.3);
  - right of easement (*erfdienstbaarheid*) (section 2.3.4);
- right to an apartment or condominium right (*appartementsrecht*) (section 2.3.5);
- joint ownership (*mandeligheid*) (section 2.3.6).

In the remainder of this section, these rights are described, together with the cadastral registration of these rights. Also the codes that are used in AKR (administrative database) are given. These codes will return in the description of the case studies in chapter 3.

### 2.3.1 Right of ownership

The most extensive right that a person can have is the full right of ownership, code ‘VE’ in the AKR (*volle eigendomsrecht*). To the exclusion of everybody else, the owner is free to use the thing, provided that its use does not breach the rights of others and that limitations based upon statutory rules and the rules of unwritten law are observed [41].

The right of ownership of a parcel has a 3D component. This becomes obvious when the upper and lower boundaries of the right lead to disputes; i.e. when more than one

person uses the parcel. Actually, the right of ownership to a parcel (as all other real rights) always relates to a space, otherwise the use of the parcel would be impossible. According to the Articles 20 and 21 of Book 5 of the Dutch Civil Code [41] the right of ownership comprises:

- exclusive use of the right of space above the parcel;
- ownership of the earthlayers beneath it;
- ownership of buildings and constructions forming a permanent part of the land (directly or by means of other constructions).

This quotation from the Civil Code indicates the ambiguity of the way ownership is defined in the third dimension: the third dimension of ownership is not explicitly bounded. The ownership to a parcel includes the competence to use the land owned. This includes the space above and under the parcel to a height and depth to which the user has (possible) interest. The use of space above and under the surface is permitted to third persons, as long as this is sufficiently high or low, that the owner cannot reasonably object to this use or when this use is regulated by other laws, e.g. by the Law on Air-traffic (*Luchtvaartwet*) which prescribes regulations for air-traffic [38] or by the Law on Mining which provides the possibility to extract minerals in the ground of private owners by concession (*Mijnwet 1810*) [36] or permit (*Mijnbouwwet 2003*) [45].

Since ownership is not explicitly limited in the third dimension, in principle the right of ownership of land reaches from the middle of the earth up to the sky. Horizontal division of this volume is only possible by establishing rights and limited rights on surface parcels, such as a right of superficies (section 2.3.2), right of long lease (section 2.3.3), right of easement (section 2.3.4), and apartment right (section 2.3.5) [127]. Horizontal division of the volume enclosing the whole parcel column leads to 3D property units, which are bounded spaces to which persons are entitled by means of real rights.

Restrictions according to Public Law (section 2.4) and restrictions imposed by regional and local land use plans, e.g. no more than five floors per building, can also restrict the owner in using his parcel (column). Restrictions according to regional and zoning plans are not registered in the cadastral registration and will therefore not be considered within this thesis.

#### **Vertical accession to real estate**

According to Dutch Law the basic rule of accession, derived from Roman Law, is that buildings and other constructions that are permanently fixed to the land are considered part of that land. Consequently constructions under or above the surface that are permanently fixed to the surface are owned by the owner of the land unless other rights or restrictions have been established on the surface parcel (*verticale natrekking*) ('superficies solo cedit') [41]. However this is not a strict rule. The owner of a construction below or above the surface is not necessarily always the same person as the owner of the land parcel.

#### **Horizontal accession to real estate**

When the legal status of separated ownership on one parcel is not established (and therefore not registered), the legal status can be obtained by the rule of 'horizontal accession to real estate' (*horizontale natrekking*) [90]. According to the Dutch Civil

Code, constructions fixed to the land are part of the property by vertical accession, *unless* the construction is part of another property. In that case the parts encroaching another parcel are part of the main part by the rule of horizontal accession (see figure 2.4). Consequently these parts do not belong to the encroaching parcel, as would be the case using the rule of vertical accession. Therefore the owner of the main construction is also the owner of parts of the construction that encroach another parcel. For example, where the ownership of a tunnel is not explicitly established and registered on an intersecting parcel, the owner of this component of the tunnel could be found by finding the point, and thus the parcel, where the main part of the tunnel is fixed to the surface, which is presumably where the entrances are (see also discussion in [70, 71]). The owner of the parcels containing the entrances can in this case be seen as the owner of the entire construction, including the components which run below the surface parcels against which no rights have been established.

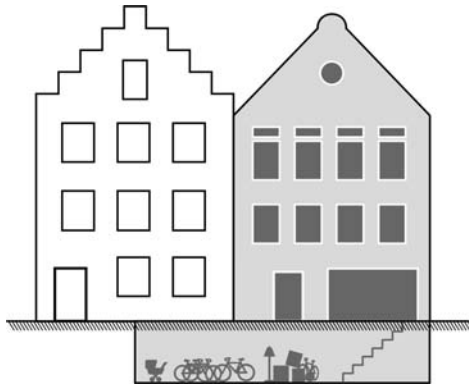

Figure 2.4: *An illustration of 'horizontal accession to real estate'. The part of the grey house that is situated under the white house (cellar) belongs to the owner of the parcel under the grey house since this part is a component of the grey house*

With a horizontal accession to real estate a factual horizontal division in ownership takes place. The legal status follows from the factual situation. Consequently, the legal status may change if the factual situation changes. The disadvantage of horizontal accession to real estate is that the legal status of the situation is not registered and therefore not clear in the cadastral registration.

The horizontal accession to real estate might conflict with the definition of the right of ownership (vertical accession to real estate). According to the Civil Code the right of ownership contains all constructions that are permanently fixed to the parcel while in case of horizontal accession to real estate the owner of a parcel that intersects with a construction is not the owner of the construction [70, 71, 218]. In principle, vertical accession always gets priority *unless* horizontal accession can be applied.

It should be noted that the horizontal accession to real estate does not justify the factual situation. It is for example not allowed to build a construction encroaching another parcel without permission of the owner of the encroached parcel.

### 2.3.2 Right of superficies

According to article 101 of Book 5 of the Dutch Civil Code the right of superficies (*opstalrecht*) is “a real right to own or to acquire buildings, works or vegetation in, on or above an immovable thing owned by another”. A construction may also intersect the surface level (located partly below and partly above the surface). The holder of this limited right is the owner of the construction. As a limited real right it restricts the original owner of the land: the owner has to tolerate the existence of the construction in, on or above his land. In case of a right of superficies, AKR uses the code ‘OS’ for the right of superficies and the code ‘EVOS’ for the right of ownership to the land encumbered with the limited real right.

A right of superficies can be used when the owner of the construction is not the same as the owner of the parcel. By means of this right, a horizontal division in ownership takes place [89], although no geometry is maintained in the cadastral registration to reflect the spatial extent of the ownership of the buildings nor of the right itself. The complete parcel is therefore affected with the right of superficies. It is possible to add a drawing to the deed recorded in the Public Registers to clarify the situation. The establishment of a right of superficies provides the possibility to dictate restrictions to the owner of the land in order to avoid damage to the construction [117].

When a right of superficies is established for a cable or pipeline, AKR uses the special code ‘OL’ (*Opstalrecht ten behoeve van leiding*). This special case of a right of superficies is in the cadastral registration not treated as a limited real right but as a legal notification.

A legal notification (*Object belemmering*: object restriction) is an indication in the cadastral registration that a restriction is imposed on the ownership of the parcel. Legal notifications are an administrative category which describe rights and restrictions but are not rights themselves. In most cases these are Public Law restrictions (section 2.4), e.g. the building on the parcel is a protected monument, or the obligation to tolerate a construction needed for a public work (e.g. a high voltage power line) imposed by special acts, like the *Belemmeringenwet Privaatrecht*.

When the restriction or right registered with a legal notification affects only a part of a parcel, the code is followed by the suffix ‘D’ (referring to the Dutch word *deel*, i.e. part). Consequently a right of superficies established for a pipeline that is intersecting with just a part of the parcel will get the indication ‘OLD’, although the location of the pipeline is not specified in the cadastral geographical data set. In general, in case of legal notifications, no spatial information is registered in the cadastral registration. It is possible to add a drawing to the deed, although this is not obligatory.

The registration of the right of superficies for cables and pipelines (code ‘OL’) was introduced in 1992. Before 1992, the AKR code ‘BZ’ (or ‘BZD’) was used in similar cases. The code BZ is referring to a special right in rem for pipelines and other works, which was made possible by the *Belemmeringenwet Privaatrecht (Zakelijk recht als bedoeld in art. 5 lid 3 onder b van de Belemmeringenwet Privaatrecht)*.

A ‘BZ’ refers to a right based on Public Law, although the right itself is a right according to Private Law. The right was established by a notary deed signed by the parties concerned. A ‘BZ’ right is in juridical sense similar to a right of superficies. A

‘BZ’ legal notification should not be confused with the earlier mentioned obligation to tolerate a construction also according to the *Belemmeringenwet Privaatrecht* (which is a Public Law restriction) (see section 2.4).

Since the introduction of the new Dutch Civil Code in 1992 it is no longer possible to establish the special right in rem registered with a ‘BZ’ code, although the old registration codes are still maintained and not converted into the ‘new’ type of right of superficies. After 1992, new ‘BZ-cases’ are established with a right of superficies because of a pipeline (AKR code ‘OL’). It is confusing that in those two cases (‘BZ’ and ‘OL’) the limited real rights in the cadastral registration are treated as legal notifications and not as limited rights.

### 2.3.3 Right of long lease

The legal status of constructions below or above the surface can also be established with a right of long lease (emphyteusis), code ‘EP’ in AKR (*erfpachtsrecht*). Code ‘EVEP’ is used to indicate the ownership of the land encumbered with the right of long lease. Right of long lease is a juridical instrument which is sometimes used in 3D situations, however this right is not specifically meant for 3D situations.

A right of long lease gives the long leaseholder the permission to hold and use the parcel of the bare owner, as if he were the owner. The deed of establishment may impose an obligation upon the leaseholder to pay a sum of money (*canon*) to the owner every year. This deed also contains an end-date of the lease.

It is not possible to impose a right of long lease to just a part of a parcel or a part of a ‘parcel column’: i.e. no (juridical) horizontal division in ownership takes place by a right of long lease. The right of long lease includes the surface parcel as well as space below and above the parcel including the buildings that are fixed to the parcel.

In some cases of 3D constructions a right of long lease has been used. Usually the bare owner of the parcel is the ‘user’ of the construction. The long leaseholder has the right to use the parcel above (or below) the construction. By means of conditions imposed on the leaseholder (described in the deed), the use and protection of the construction can be arranged and also the dimensions to which the right of long lease applies (which causes a factual horizontal division in ownership).

Again the geometry of the space to which the right applies is not maintained in the cadastral registration and can only be specified in a drawing attached to the deed. The right of long lease has been applied to (parts of) the metro in Amsterdam [90]. The geometry of the metro or of the right itself is not known in the cadastral geographical data set, nor in the administrative database. The only place where information could be found on the factual situation is in the deeds archived in the Public Registers which may be accompanied by scanned and paper drawings [90].

### 2.3.4 Right of easement

An easement (servitude) is a charge (encumbrance) imposed upon a parcel (the serving parcel), in favour of another parcel, the dominant parcel [41] (*erfdienstbaarheid*). An

example of this is when an owner A of a parcel can reach the public road easier by crossing the parcel of his neighbour B rather than crossing his own parcel. An easement can be imposed on the parcel of B in favour of the parcel of A, which makes it possible for owner A to cross the parcel of B.

It is also possible to establish a right similar to a right of easement without linking it to a dominant parcel. This can be used when a right of easement is established for a pipeline which has no clear dominant parcel. The restriction on the serving parcel (*Kwalitatieve verbintenis*: restrictive covenant, literally: qualitative obligation) is established in a deed archived in the Public Registers, while AKR registers a ‘KV’ code as a restriction on the serving parcel (as a legal notification). The restriction is linked to the subject who causes the restriction. A *Kwalitatieve verbintenis* is a contract which imposes an obligation on an owner of land to tolerate a pipeline. This obligation is also binding for future owners.

In general, the deed establishing an easement may impose an obligation upon the owner of the dominant property to pay to the owner of the serving property a sum of money. The easement must be exercised in a way that causes the least inconvenience to the serving property. In the example this means that A has to take the shortest path across the parcel of B. When the dominant property is divided, the easement continues to exist for the benefit of each part to which it may be beneficial [41]. The easement is linked to a parcel (establishing a parcel to parcel relationship): when the parcel is sold, rights and restrictions of an easement are taken over by the next parcel owner.

Apart from the easements without dominant parcels (code ‘KV’), easements are not registered in AKR as limited real rights and they also cannot spatially be defined in the cadastral geographical data set, although a drawing can be added to the deed specifying the spatial extent of the easement. However, in case of easements linked to dominant parcels, the scanned deeds (and drawings) will not be directly accessible through the cadastral database (the existence of the easement is not known as limited real right in the cadastral database). The vertical dimension of a right of easement can be relevant, for example when a right of easement is established for a bridge above the serving parcel or for a pipeline that crosses a parcel. It is also possible to establish a right of easement for having a building on a serving parcel. In all these cases, the registration would be improved firstly by registering the existence of the easement as limited real right in the cadastral database, and secondly by a 3D visualisation of the space where the right applies.

### 2.3.5 Apartment right

The most frequently occurring 3D situations are apartment complexes. Most countries have introduced juridical instruments to establish the ownership of apartment units. In Germany, France and most other European countries legislation on apartment ownership is based on the so-called “dual system” [3]. Every apartment owner has the full ownership of a part of the building (apartment). The communal areas of the building, such as staircases and elevators are held in co-ownership. This can be described as compulsory co-ownership, or an accessory restricted co-ownership. “Accessory” because it cannot be separated from the ownership of the apartment,



“restricted” because during the time the building is divided into apartments, the separation and division of the common areas is not possible.

Some European countries have adopted the “unitary system”, e.g. Norway, Austria, Switzerland and the Netherlands [3]. It is important to notice that in this system the apartment ownership is based on co-ownership of the whole complex (consisting of ground parcel(s) and buildings on the parcels(s)).

Article 106 of Book 5 of the Dutch Civil Code [41] describes apartment ownership or apartment right (*appartemensrecht*) as follows:

1. An apartment right means a share in the ownership of the property involved in the division which also comprises the right to exclusive use certain parts of the building which, as indicated by their lay-out, are intended to be used as separate units. The share can also include the right to exclusive use of certain parts of the land pertaining to the building.
2. An apartment owner means a person entitled to an apartment right.

The owners of the apartment units are joint owners of the entire building and the ground below. The underlying ground may consist of several parcels which can be disjoint. The co-ownership includes the right to have the exclusive use of a certain part of the building: the apartment unit (*exclusief gebruikersrecht*). This means that the persons do not legally own a separate apartment unit, although the apartment ownership can be mortgaged.

The division in apartment rights is based on a notarial deed, the so-called “deed of division” (*splitsingsakte*). A plan obliged in this deed is maintained in paper and scanned format in the Public Registers. This plan gives an overview of the building and a detailed plan of each floor. Thick dark lines indicate the borders of every apartment, i.e. the area of exclusive use. How apartment units are registered in the current cadastral registration will be described in more detail by a case study in chapter 3.

Though an apartment right is the best way to establish multilevel ownership on one parcel, the registration of apartment units can still be improved. Only the ground parcel(s) of the apartment building is (are) maintained as part of the cadastral geographical data set and therefore the individual apartments cannot be recognised on the cadastral map. Consequently apartment units cannot spatially be queried, although ownership information on the individual units is available in AKR. Another complication that can be mentioned is that an analogue (or scanned) drawing is used to clarify the cadastral situation in the deeds. Spatial information available in vector format and in real world coordinates would make it possible to integrate the information from the drawings with the cadastral geographical data set.

Basic characteristics of apartment units are that the apartment units within one complex have a juridical relationship with each other (e.g. they share common area in a building) and the apartment complex is concentrated on one or several parcel(s). However apartment rights are also used in the case of independent stratified properties crossing parcel boundaries, e.g. for shops and dwelling units in one building or

for public underground parkings, which motivates the search for a more general solution for 3D situations. This solution should better reflect the nature of independent multilevel ownership on one parcel or crossing several parcels.

### 2.3.6 Joint ownership

Dutch land law knows a special type of joint ownership: *mandeligheid* (compare the French “mitoyenneté”). This is a right to land and/or a construction that can be registered similar to common area as in condominiums. This immovable thing arises when an immovable thing is joint owned by the owners of two or more properties and where it is designated by them for the common benefit of those properties by a notarial deed between them, which is then recorded in the Public Registers [41]. Joint ownership comprises the obligation of each joint owner to give the other joint owners access to the thing held in joint ownership. Things held in joint ownership must be maintained, cleaned and, if necessary, renewed at the expense of all joint owners. A joint owner of a thing held in joint ownership may transfer his share in the thing to the other joint owners separately from his property. This characteristic is why joint ownership is in some cases favoured above registration by means of condominium by which it is not possible to transfer shares separately from the property (apartment unit). A specific cadastral characteristic of joint ownership that it is only registered on a parcel and not linked to a subject. The 3D characteristic of an immovable thing held in joint ownership can be of importance in cadastral registration when not the whole parcel is held in co-ownership, e.g. underground parking places, swimming pools, tennis courts, aeriels etc.

## 2.4 3D registration and Public Law

The Kadaster also registers restrictions in the ownership of parcels as dictated by Public Laws (*Publiekrechtelijke Beperkingen*). For a better understanding of the Public Law restrictions that need to be registered, a selection of such laws containing a 3D component was made. These laws as well as the cadastral registration of the restrictions imposed by these laws will be described below:

- *Belemmeringenwet Privaatrecht*: obligation on the owner of land to tolerate a construction for public good (section 2.4.1);
- Law on Monuments (*Monumentenwet*): registration in order to protect historical monuments (section 2.4.2);
- Law on Soil Protection (*Wet Bodembescherming*): registration of severe soil pollution (section 2.4.3).

A proposal has been prepared by the Ministry of Spatial Planning, Housing and the Environment to renew the Public Law recordings and to register legal restrictions issued by the national government (about twenty-five) and by the provincial government (about ten) in the cadastral database as listed in the proposal. At this moment, the list still needs to be finalised [238]. Examples of laws which will lead to

a cadastral registration of a restriction on a parcel are *Wet voorkeursrecht gemeenten*, *Belemmeringenwet privaatrecht*, *Landinrichtingswet*, *Reconstructiewet Midden-Delfland*, *Woningwet*, *Natuurbeschermingswet*, *Wet geluidhinder*, *Deltawet*, *Wet op de lijkbezorging* and the *Boswet*. The municipalities will be responsible for a registration of restrictions (also on parcels) according to municipal regulations. Therefore they will maintain a municipal restriction register, which is linked to the cadastral registration [238].

All the restrictions mentioned here are registered on parcels as object restrictions (*Object belemmering*), i.e. as legal notifications. The parcels are affected with a restriction in the right of ownership, which is stored in the administrative database. The restrictions are registered, not the factual objects which cause the restriction (monument, cable, pollution etc.).

### 2.4.1 Belemmeringenwet Privaatrecht

According to a special law in the interest of public good (*Belemmeringenwet Privaatrecht*) [37] the owner of land can be obliged to tolerate constructions held by others such as lampposts, electrical cables, water pipes, telecom pipes, tunnels etc. [194]. AKR uses the codes ‘BP’ and ‘BG’, or ‘BPD’ and ‘BGD’ for an obligation established for a part of a parcel. This restriction is used only when no other agreement can be arranged with the owner (e.g. right of superficies, personal rights described in contract etc.). In addition, the restriction does not allow the imposition of precisely described limitations on the user of the parcel in order to protect the construction against damage. Therefore this restriction is rarely used.

Since the objects themselves (cables, pipelines, tunnels) are not registered, only the parcels are known below (or above) which a construction is situated. The exact (horizontal and vertical) location of the construction is not known in the cadastral registration, although it is possible to make the outlines of an underground construction visible on the cadastral map.

The obligation of toleration by law only holds for cables and pipelines for public good. Consequently, for those cables and pipelines for which no toleration can be enforced (when it does not serve the public in total) and for which no right of superficies has been established, nothing is registered.

According to Private Law, the owner of the intersecting parcel becomes the owner of the cable or pipeline, since the construction is permanently fixed to the surface (*verticale natrekking*). If horizontal accession gets priority to vertical accession, (as in most cases) the owner of the parcel where the cable or pipeline is permanently fixed to the surface (comes to the surface) becomes the owner of the cable or pipeline. An exception to the vertical and horizontal accession to real estate are the type of pipelines that fall under the Law on Telecommunication [44]. For an extensive juridical discussion on the ownership of cables and pipelines see [70, 71].

According to a decision of the Dutch Supreme Court in June 2003 [46] telecom-networks are immovable goods and these cables are always owned by the holder of the permit to exploit the cable. This holder has (usually) a right on the parcel where the cable comes to the surface. Since telecom-networks are considered as immovable

goods, the cadastre is obliged to register the transfer of networks as well as the establishment of limited real rights on them. It is expected that in the future this decision will apply to other cables and pipelines (gas and electricity) as well. It should be noted that a lot of infrastructure objects are or can be used for telecommunication and they may all fall under this law. The registration of telecom-networks is done in the following way. If a telecom-network is transferred, the holder of a telecom-network offers the spatial description (centre line) of the network to the cadastre. The network is then registered on at least one ‘anchor’ parcel on which the holder of the network has a real right, e.g. on a parcel where a network substation is located. The other intersecting parcels do not need to be mentioned in the deed but can be found by consulting the drawing archived in the land registration (see figure 2.5).

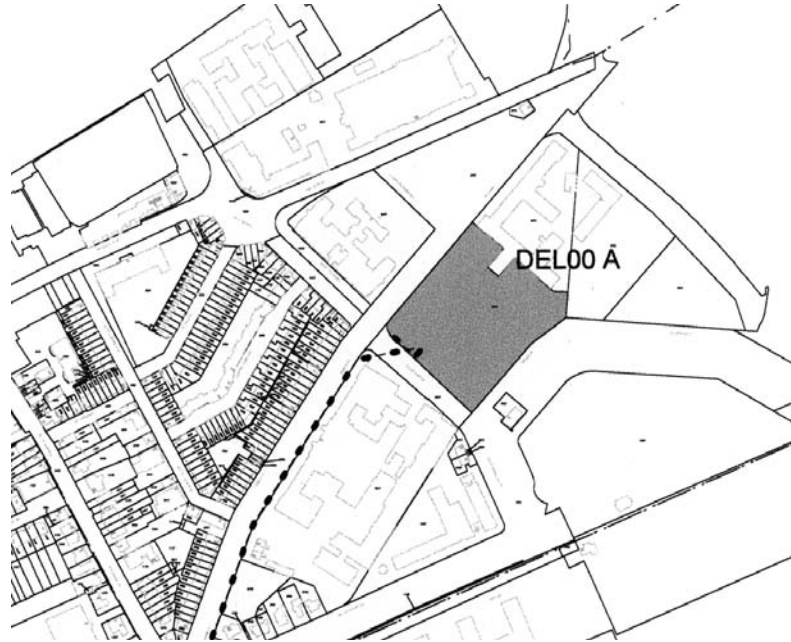

Figure 2.5: *Example of drawing added to deed in case of a telecom-network.*

On all intersecting parcels an object restriction (legal notification) can be registered, AKR code ‘TC’ or ‘TCD’. The spatial description of the network can only be incorporated in the topographic part of LKI and not in the cadastral geographical data set [107]. According to article 174 and 175 of Book 6 of the Dutch Civil Code the manager of the cable or pipeline is always responsible for damage caused by a defect in the cable or pipeline or by hazardous material transported through the pipeline whether he is the juridical owner or not. This also holds if the manager is not registered as the owner of the cable or pipeline.

The establishment of a right of superficies (right according to Private Law) for cables or pipelines provides the possibility to keep the right of ownership explicitly with the cable or pipe holder. This special case of right of ownership (right of superficies for cables and pipelines) is registered as such by the Kadaster by using the code ‘OL’

(*Opstalrecht ten behoeve van leiding*). As was seen in section 2.3.2 this is a legal notification in the administrative database [90].

## 2.4.2 Law on Monuments

The Law on Monuments (*Monumentenwet*) [39], established in 1961, protects buildings and parts of buildings with monumental value but also earth layers below the surface with archaeological value. According to this law, it is possible to impose restrictions on the owner of a monument, e.g. not rebuild certain parts of a house. The restriction is registered on the whole parcel (code ‘MW’ or ‘MWD’ when only part of the parcel is encumbered with a restriction) while the geometry (outline of the monument or archaeological site) is not maintained in the cadastral register (figure 2.6).



Figure 2.6: A selection of parcels (highlighted in the map) encumbered with a notification because of a monument in the city centre of Delft.

More details on the exact location of the monument on the parcel can be found in the Public Registers on drawings added in deeds. To protect monuments, a complete and correct registration of monuments is necessary. An owner of a monument gets funding from the government. This also requires a correct registration of monuments in order to assign the funds to the right person. Another reason why cadastral registration according to the Law on Monuments is becoming more important is that recently archaeological sites have received more protection under European agreement [216]. This agreement states that planners of new projects (infrastructure or new city sites) have to take care of the conservation of archaeological treasures in the unexplored subsurface. Cadastral registration can provide the planners of new projects with information on archaeological sites.

Often only the façade of a building or just a part of a building is a monument and not the whole building. In current cadastral registration the whole parcel is encumbered with a ‘MW’ (or ‘MWD’) code. Although the actual part that covers the monument is

indicated in the deed archived in the Public Registers, a 2D (or 3D) spatial description of the monument in the cadastral registration would show immediately that not the whole parcel (or building) is a monument. Also the spatial description of underground space with archaeological value in the cadastral registration would provide insight into the exact location of the protected site, without having to look in the Public Registers.

At the moment about 60,000 monuments have been registered in the cadastral registration (using one or several parcels). The Register for Monuments (*Monumentenregister*) [179] also registers monuments. Consequently there are two sources for monuments: the cadastral registration that records the existence of a monument on a whole parcel and the Register for Monuments that records the monument itself. However, the Register of Monuments was out of date and contained many errors since it was never linked to the cadastral registration. Therefore, the Register for Monuments started a project in 1999 to clear their register by linking it to the cadastral registration. The clean up action is a tremendous job, since all monuments have to be checked to see if the recording of a monument is still valid, although the process is performed semi-automatically. According to the plans, it will take 200 man-years and 15 million Euro to clean the whole register [180]. Spatial information on monuments (2D and preferably 3D) in the cadastral registration could support the Register for Monuments to maintain a good (up-to-date and precise) registration.

### 2.4.3 Law on Soil Protection

According to the Law on Soil Protection (*Wet Bodembescherming*) [42], cases of severe soil pollution have to be registered in the administrative part of the cadastral registration, using code ‘WB’ or ‘WBD’. When (a part of) the subsurface of a parcel is polluted, the parcel is indicated as a polluted parcel. The provinces are obliged to report a severe pollution to the Kadaster. With this report a (2D, analogue) drawing of the location of the pollution is archived in the Public Registers (see figure 2.7). However since the accuracy of the drawings is not prescribed, the exact locations of pollution are still very unclear in most cases. 3D information on pollution locations is totally lacking. The disadvantage of this registration is that, due to lack of spatial information, the whole parcel becomes affected by the decision. The exact location (in the horizontal as well as in the vertical dimension) of the pollution is not registered and therefore not known in the cadastral registration.

## 2.5 Other relevant aspects of cadastral registration

In this section other aspects of cadastral registration in the Netherlands are described which are relevant for this research or will occur in the case studies in chapter 3.

### 2.5.1 Underground objects in the cadastral registration

A special case of legal notifications is the registration code ‘OB’ or ‘OBD’ (*Ondergronds Bouwwerk*: underground construction), which was introduced in 1998. This is



transferred, or a limited real right (e.g. a right of superficies) is established for only a part of a parcel (e.g. in case a tunnel intersects with only a part of the parcel). The boundaries of the new parcels are based on the part of the parcel that is transferred, or is encumbered with the limited right. However, unlike many other countries, in Dutch law it is not compulsory to obtain the permission of authorities preceding the subdivision. Additionally it is not necessary that new parcels are measured and created in the (spatial part of the) cadastral registration before the ownership is transferred or before the limited right has been established. Therefore, it is common practice that new parcels are created months (or in some cases even years) after the notary deed establishing the limited right, or transferring a part of a parcel has been registered in the Public Registers. It is also possible to subdivide a part parcel into parts before surveying.

As long as the new parcel boundaries are not measured, the cadastral registration uses the expression ‘part parcel’ (*deelperceel*). Awaiting the formal spatial creation of the new parcels, the administrative number of the parcels to be created is the old parcel number followed by the suffix ‘D’ and an index number. It is important to notice that those part parcels are in fact still one (original) parcel on the cadastral map. An example will make things clear. L, the owner of a parcel numbered A 1000, establishes a right of superficies (held by S) on a part of this parcel. In this case the original parcel must be subdivided into two new parcels, one held in full ownership by L, and the other held in restricted ownership by L, encumbered by the right of superficies held by S. Awaiting the formal division the two part parcels will get the numbers A 1000 D1 and A 1000 D2. On the cadastral map the part parcels are drawn at the same location as the original parcel A 1000. Only after a surveyor of the Netherlands’ Kadaster has measured the new parcel boundaries, are new numbers assigned, e.g. A 1199 and A 1200 and the new parcel boundaries become visible on the cadastral map.

Not in all cases is a new parcel created when a limited right only affects part of the (original) parcel. An important exception to this rule is the right of superficies concerning cables and pipelines (art. 6 *Kadasterbesluit*) [40]. Even when the location of a cable or pipeline is indicated in the notary deed establishing this right, the parcel will not be subdivided. The ‘BZD’ (before 1992) or the code ‘OLD’ (after 1992) will be used instead of ‘OS’ as in ‘normal’ cases of right of superficies (see section 2.3.2).

### 2.5.3 Frequency of types of cadastral recordings

To see how frequently the limited rights and legal notifications as described in this chapter currently occur, we examined the cadastral database of September 2003. The next table shows the frequency of AKR codes, referring to limited rights and legal notifications described in this chapter, as they occurred in the cadastral database of September 2003. The numbers also include the notifications and limited rights that were established on part of parcels (using the suffix ‘D’).

OS	OL	TC	BZ	EP	BP/BG	WB	MW	OB
63,538	225,779	1,569	836,702	331,809	650	195,009	111,223	1,532



OS = right of superficies  
 OL = right of superficies for pipeline, registered after 1992  
 TC = parcel used to register telecom-network  
 BZ = similar to OL, but registered before 1992  
 EP = right of long lease  
 BP or BG = imposed toleration for public good  
 WB = restriction because of Law on Soil Protection  
 MW = restriction because of Law on Monuments  
 OB = underground object

It should be noted that these figures only indicate how often a specific code is registered in the cadastral registration. The question as to whether the registration refers to a 3D property situation cannot be obtained from these figures. The total number of parcels in the database of September 2003 is 6,595,393. The topographic part of the cadastral registration (LKI) was queried for occurrences of transport systems and telecom-networks. This resulted in no occurrences, although about 9000 pipelines were present in the data set.

The numbers in the table underline once again the need for more information in case of 3D situations. Almost two million recordings were found that *could* indicate a 3D situation. The apartment units are even left out from these numbers. In total 120,188 parcels were found in the database of September 2003 which contain apartment complexes that consist of 1,260,573 apartment units. In total 50,743 parcels are registered as parcels which are subdivided but not remeasured yet (which means they contain two or more part parcels). Another interesting result of this examination was that 1,569 parcels have been found with a 'TC' code (parcels intersecting with a telecom-network) while only five networks have been registered, with three holders in total:

- GC PAN EUROPEAN CROSSING NEDERLAND
- ENERGIS N.V.
- MCI WORLDCOM

This indicates the overhead of information in case of infrastructure objects.

## 2.6 Conclusions

In this chapter 3D aspects of cadastral registration according to Dutch Private Law and Public Law were described.

### Establishing the legal status of 3D situations

The most important cadastral registration is the right of ownership. The right of ownership is established on a parcel and applies for all space above and below the surface parcel, i.e. the ownership of a parcel is not limited in the third dimension. An owner of a parcel can be restricted in using the whole parcel column by establishing limited real rights on the parcel, by establishing apartment rights or by imposing Public Law restrictions.

When no rights are established, the rules of vertical and horizontal accession apply. Vertical accession means that the owner of a parcel also owns all constructions which are permanently fixed to the surface parcel. Horizontal accession defines that parts of a construction encroaching another parcel (above as well as below the surface) are part of the main part by accession. Both vertical and horizontal accession are a consequence of the factual situation and not established with (limited) rights and can therefore conflict in a certain situation. Another disadvantage is that the legal status of the 3D property situation, which is a consequence of the factual situation, is likely to change with the creation or destruction of constructions.

An explicit horizontal division in property can only be juridically effectuated by either a right of superficies or an apartment right. Also a right of long lease and a right of easement are limited real rights which can restrict the bare owner (i.e. the person who holds the ownership of a parcel that is encumbered with limited real rights) in using the whole parcel (column). Although these rights do not establish a juridical horizontal division in ownership, conditions in the deeds establishing these rights can define (and thus limit) the space where the specific right applies to. Apartment rights and limited real rights cause therefore a horizontal division of the parcel (column) into 3D property units which are bounded volumes to which persons are entitled by means of real rights.

Restrictions according to Public Law can also restrict an owner of a parcel in using his parcel. In this chapter a selection of Laws were described that impose restrictions according to Public Law and that are registered in the cadastral database:

- restriction because of an obligation to tolerate a construction the for public good (this does not regulate the ownership of the construction);
- restriction according to Law on Monuments;
- restriction according to Law on Soil Protection.

### **Registration of the legal status of 3D situations**

Once the legal status of 3D situations has been established (the juridical step), the next question is how these limited rights and (Public Law) restrictions are registered in the cadastral registration and if information on the space to which rights apply is registered and available in the cadastral registration. The legal status of (2D) parcels as well as the spatial extent of parcels are very well registered in the (Dutch) cadastral registration. However, as can be concluded from this chapter, there are several reasons why information on the legal status of 3D situations is not (always) straightforwardly accessible.

The legal status of constructions and phenomena above, on and below the surface (buildings above roads, tunnels, pipelines, monuments and pollutions) is not registered in the current cadastral registration. The legal status in those situations can be found by examining the (limited) rights that are established (and thus registered) on the surface parcel(s) that intersect with a construction or phenomenon. The reason for this is the basic principle of a cadastre, i.e. rights and limited rights are established and registered on (2D) parcels. The function of a real right and whether it concerns a construction on, above or below the surface is not registered.

Spatial information on rights can be added in deeds, but is not incorporated in the current cadastral registration (to what space does the right apply?). The current

(2D) cadastral geographical data set (the spatial part of the cadastral registration) only contains parcels and buildings. Outlines of other real world objects for reference purposes can be inserted into the topographic data set that is maintained by the Kadaster.

Only in the case of apartment units, the registration provides clear administrative information on the factual situation, since the administrative database does contain information on individual apartment units. To get a spatial overview of the property situation of apartment rights, the deeds archived in the Public Registers need to be examined. Once the deeds are digitally accessible through the cadastral database, which will be possible within this year (2004), the overview drawings of apartment complexes can be viewed directly from the cadastral registration.

A person who queries the cadastral registration wants to obtain insight into the legal status of the situation. However since constructions are not registered as themes and since rights are mostly also not explicitly related to physical objects in the real world, the accessibility of information on the legal status of 3D situations is poor.

The necessity of improving information on 3D situations was emphasised by a query in the cadastral database of September 2003, which yielded about two million cadastral recordings of situations in which more than one person has interest in one parcel. However, in those cases further investigation needs to be done to find out the spatial extent of the concerning rights and restrictions in order to get insight into the factual situation.

As can be concluded from this chapter there are many recordings both according to Private Law and Public Law for which a 3D approach for registration would give better insight into the factual situation and would provide better means to manage the situation (e.g. in the case of monuments and soil pollution).

Based on the inventory in this chapter, we can define two basic limitations in the current cadastral situation as it applies 3D situations. Firstly, the space where a right applies for is not registered and not available in the cadastral registration. Secondly, constructions and other phenomena above or below parcels are not registered as such in the cadastral registration and cannot be queried. Since there is no link with a 3D representation of reality (representation of physical construction), the cadastral registration cannot properly reflect the real situation. Therefore a 3D approach comprises two aspects: give insight in spatial component of (limited) rights on the one hand and make it possible to maintain spatial as well as non-spatial information on constructions in addition to parcels on the other hand.



## Chapter 3

# Current practice of 3D registration: case studies<sup>1</sup>

In chapter 2, 3D aspects of the current Dutch cadastral registration were described. To illustrate the way 3D situations are currently registered in the Dutch cadastral registration, six case studies in the Netherlands were selected. The aim of the case studies is to show if current registration possibilities are sufficient in the case of stratified property or if improvements are needed. 3D situations are still relatively rare and mainly occur in urban areas. However some 3D situations are particularly for rural areas, e.g. a pipeline crossing several parcels owned by private persons. The case studies were selected in such a way that they form a representation of the types of 3D situations that currently occur in practice. Another criterion in the selection process was that the cases should be simple in order to illustrate as clearly as possible the constraints of current registration. The case studies are divided into building complexes (section 3.1) and subsurface infrastructure objects (section 3.2). Building complexes mostly occur in urban areas and interact with other types of land use. In those cases mostly private parties are involved. Subsurface infrastructure objects are mainly constructions meant to serve the public. Other cases (e.g. soil pollution, archaeological sites and monuments) are not studied because it is the intention of these case studies to get a picture of the complexity of cadastral registration of 3D situations in general, rather than to analyse all possible cadastral recordings with a 3D component, which are numerous and all have their specific characteristics. Therefore the most common and basic types of cadastral registration have been selected. It can be expected that types of cadastral registration that are not dealt with in these case studies, would show similar basic complications. The chapter will end with conclusions.

Future cadastral registration of the selected case studies will be shown in chapter 12, where the prototypes developed as part of this research are applied to the case studies introduced in this chapter.

---

<sup>1</sup>This chapter is based on [200] and [201].

## 3.1 Building complexes

The main characteristics of property units in building complexes are that two or more parties are involved in the ownership of the building and that different property units, often with different functions, are located within one building complex, concentrated on one or several ground parcel(s). The demand that private persons have concerning the cadastre is that their properties are registered properly. Cadastral query must provide sufficient insight into what persons own, and the location of the property boundaries. Since real estate has significantly gained value during the last decades, it has become more important to register property clearly and unambiguously. Building complexes are therefore relevant objects to study current registration possibilities of 3D situations. How are property units in building complexes registered at the moment? In what way does the cadastral registration provide insight into the property units in building complexes? Does the cadastral registration provide insight into the location of boundaries of the property units, also in the third dimension? To answer these questions, three case studies are described: an arch (building above a road), a multi-functional building complex and an apartment complex.

### 3.1.1 Case study 1: Building complex in The Hague



Figure 3.1: *Building over a road*

Figure 3.1 shows an example of a 3D situation: a building over a highway in The Hague. The right of property of the building has been established by establishing rights on the three intersecting parcels (figure 3.2). On the cadastral map (figure 3.2) you can see the outlines of the building (on surface level) and the surface parcels. The arrow indicates the view position of the camera in figure 3.1. The firm ‘Ing Vastgoed Belegging BV’ is holder of the whole building. The rights and restrictions established on the intersecting parcels are as follows. The municipality holds a restricted right of ownership on parcels 1719 and 1720. ‘Ing Vastgoed Belegging BV’ possesses an unrestricted right of ownership on parcel 1718, a right of superficies on parcel 1719

and a right of long lease on parcel 1720. In this example there is one building with one owner ('holder'). However three parcels are used to establish the legal status of the whole building.

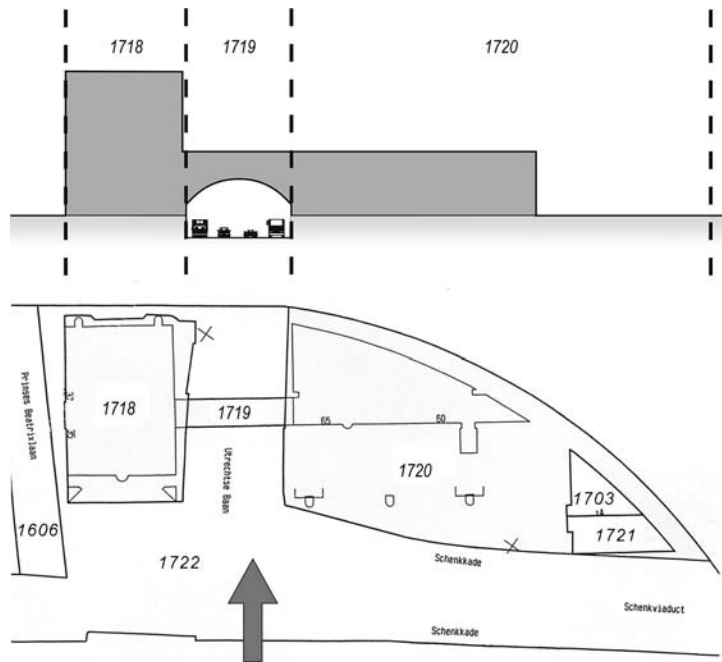

Figure 3.2: Cadastral map of the building in figure 3.1. The arrow indicates the position of the camera.

### 3.1.2 Case study 2: The Hague Central Station

The Hague Central Station is a building complex in the city centre of The Hague. It is a combination of a multilevel public transport interchange (bus/tram station and railway station), an office centre and shops (see figure 3.3 (a)). All parts of this complex are owned by different governmental and commercial organisations. This is achieved by dividing the high building (office and railway station) into apartment rights, and the establishment of a right of superficies for the bus/tram station.

The use of apartment rights will be discussed in more detail in the next case. Here we take a closer look at the right of superficies. A right of superficies is a limited real right that entitles its holder to build and have a building (or an other type of construction) in, on or above the land owned by another. As a limited real right it restricts the landowner in his use: he has to tolerate the existence of (a part of) the building on his parcel. On the other hand, the holder of the right of superficies is the full owner of the erected building. In the case of The Hague Central Station, the holder of the right of superficies is entitled to build and own the tram/bus station on

top of the railway platforms. The cadastral map of this complex is shown in figure 3.3 (b). The arrow indicates the position of the camera in figure 3.3 (a). The bus/tram station on top of the railway platform is erected on parcel '13295', the business center is on top of the railway station on parcel '12131'.

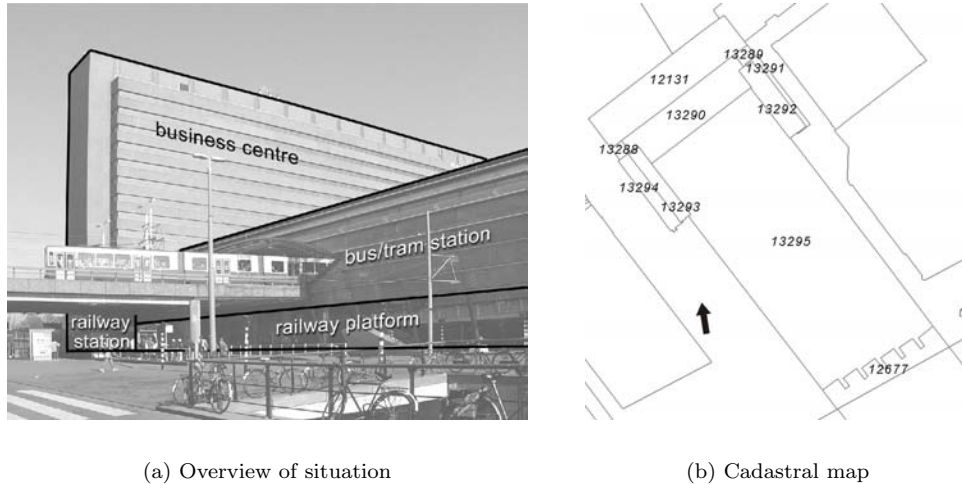

Figure 3.3: *The Hague Central Station, combination of a business centre, a railway station and a bus/tram station.*

According to the cadastral DBMS (AKR), the right of the concerning parcels are:

Parcel	Kind_of_right	Right_owner
12131	VE	VER. VAN EIG. STICHTHAGE
		divided into two apartment untis:
12205A0002	VE	STICHTHAGE TRUST B.V. GEV. TE'S-GRAVENHAGE
12205A0001	VE	NS VASTGOED BV
13288	VE	NS VASTGOED BV
13289	VE	NS VASTGOED BV
13290	VE	NS VASTGOED BV
13291	EVOS	NS VASTGOED BV
13291	OS	Gemeente Den Haag
13292	EVOS	NS VASTGOED BV
13292	OS	Gemeente Den Haag
13293	EVOS	NS VASTGOED BV
13293	OS	Gemeente Den Haag
13294	EVOS	NS VASTGOED BV
13294	OS	Gemeente Den Haag
13295	EVOS	NS Railinfratrust BV
13295	OS	Gemeente Den Haag

VE = full right of ownership

OS = right of superficies

EVOS = right of ownership, restricted by a right of superficies



Analysing these results, it is clear which persons have a right on the relevant parcels. For example for parcel 13295, AKR shows that “NS Railinfratrust BV” is owner of the land (with the railway platforms), and that the municipality of The Hague (in Dutch: *gemeente Den Haag*) is holder of the right of superficies (tram/bus station). However, neither these data nor the cadastral map give insight into how the rights are divided in the vertical dimension on every single parcel. There is also no indication in the cadastral registration that the municipality is the factual owner of the bus/tram station. A study in the Public Registers did not reveal much more information. Except for parcel 12131 (divided into apartment rights), the concerning deeds do not contain a spatial description or a (clear) drawing to clarify the division into 3D property units.

### 3.1.3 Case study 3: Apartment complex

A typical form of multiple use of space, known in Dutch law since 1953, is apartment ownership (condominium ownership). For this case, we used a ‘simple’ apartment complex, consisting of one ground parcel and three apartments. One apartment is located on the ground floor, and the two other apartments are located on the second and third floor, next to each other, with an entrance on ground level (see figure 3.4).

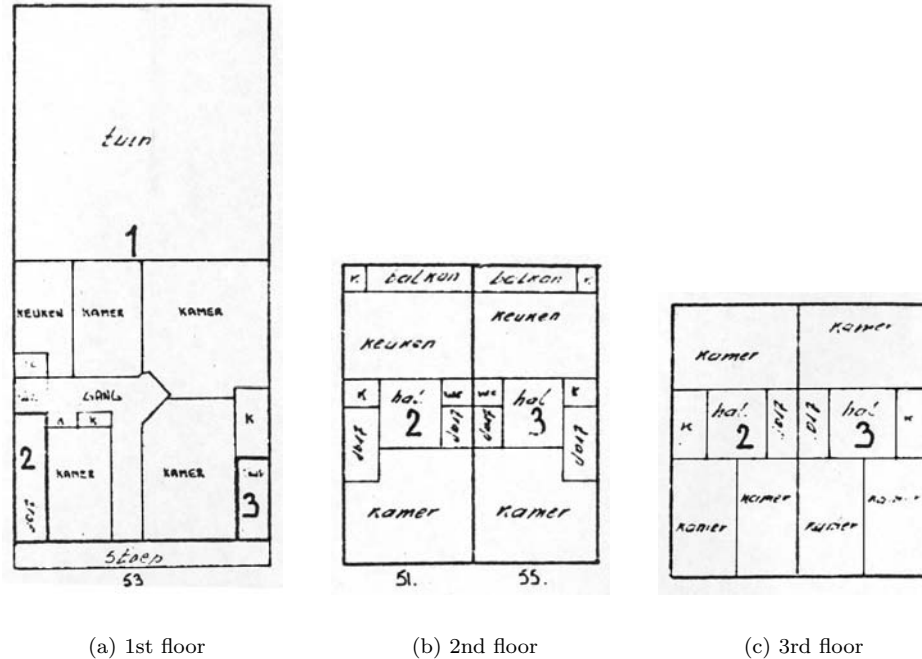

Figure 3.4: *Apartment complex used in case study.*

The deed of division of this apartment complex (archived in the land registration) contains a drawing with a cross-section and the overview of every floor (see figure 3.5). The individual apartments are numbered. The rights at the location of the apartment complex according to the cadastral registration are as follows:

Parcel	Kind_of_right	Right_owner
5238 G0	VE	VER. VAN EIG. I.HOORNBEKSTRAAT 51-55, DELFT divided into three apartment units:
6408 A3	VE	PERSON1
6408 A2	VE	PERSON2
6408 A1	VE	STOTER

VE = full right of ownership



(a) 1st floor

(b) 2nd floor

(c) 3rd floor

Figure 3.5: Drawing added to deed of division.

At first glance it seems that there are four owners, the “*vereniging van eigenaren*” (association of owners) and the holders of each of the three apartments. But this conclusion is incorrect. The parcel 5238 G0 refers to the ground parcel with the apartment complex erected on it. In practise the Kadaster names the “*vereniging van eigenaren*” (the association of owners) as owner. From a legal point of view this is not correct. The complex is co-owned by all the apartment owners, not by the association. In Dutch law the association of co-owners is merely a legal body entrusted with the day-to-day administration and management of the complex. All the co-owners of the complex are by definition members of this association, which is not explicitly registered in the cadastral registration.

Apart from the (co-owned) ground parcel, the individual apartments are each indicated by a unique number (6408 A1, 6408 A2, 6408 A3). The suffix A shows that this number refers to an apartment right. The last digit is the same as the apartment number in the deed of division.

Importantly the individual apartments, the areas of exclusive use, cannot be found on the cadastral map (see figure 3.6). The land registration has to be queried to find the plan of division. Addition of (3D) spatial information on the individual apartments in the cadastral registration would enhance insight. Another disadvantage of current apartment registration is that the plans in the notarial deeds are only available on analogue (and in the future on scanned drawings) in a local coordinate system (in 2D

layers). When spatial information on apartment units would be available in vector format in the national reference system, this information could be incorporated as part of the cadastral geographical data set or in other geo-data sets (e.g. topographic data) when requested.

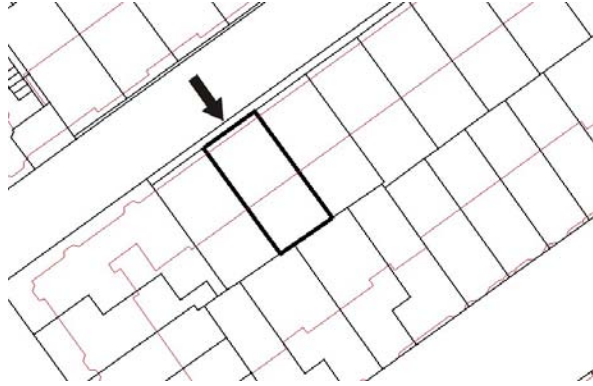

Figure 3.6: *The cadastral map of the apartment complex in figure 3.4. The parcel in question has been drawn with a thicker line-style. The front of the building is indicated with an arrow. Note that the parcel is larger than the footprint of the building, since the parcels also includes a garden ('twin' in drawing of deed of division).*

## 3.2 Subsurface infrastructure objects

Infrastructure objects are objects that are necessary to transport all kinds of things (cars, trains, electricity, water, communication). The main characteristics of infrastructure objects are their benefit to the public, their linear shape, and the fact that they cross parcel boundaries. From a cadastral point of view, it is important to register the property rights of infrastructure objects and to register public restrictions because of the infrastructure objects, not merely to secure the value of the real estate for the persons involved, but also to indicate who is responsible for the object (for example in case of damage). In addition, establishment of rights on infrastructure constructions provides a means to protect the construction against damage by specifying conditions in the accompanying deeds. A precise registration is also required, since the holder of the construction is usually obliged to pay the parcel owner a sum of money. Finally, information on the exact location of tunnels and pipelines is indispensable in risk management with regard to the increased attention on calamities in the past ten years (although it can be questioned if this is a specific cadastral task).

In this section three case studies of subsurface infrastructure objects are described (a railway tunnel in an urban area, a railway tunnel in a rural area, and two utility pipelines) to show the possibility to locate infrastructure objects in current cadastral registration.

### 3.2.1 Case study 4: Railway tunnel and station in urban area



Figure 3.7: *Rijswijk railway station (left) and kiosk (right).*

An interesting case of multiple use of space in the Netherlands can be found in the centre of Rijswijk, a suburb of The Hague. Some years ago the railway line running through this town was tunnelled. On top of this tunnel buildings were constructed. A small part of the tunnel area is shown in figure 3.7 and 3.8. In figure 3.9 the cadastral map of the situation is shown. According to AKR the following rights have been established on the parcels:

Parcel	Kind_of_right	Right_owner
7854	OS	NS VASTGOED BV
7854	EVOS	NS RAILINFRATRUST BV
7855	OS	NS VASTGOED BV
7855	EVOS	NS RAILINFRATRUST BV
7856	VE	NS VASTGOED BV
7857	OS	NS VASTGOED BV
7857	EVOS	NS RAILINFRATRUST BV
7944	OS	DE GEMEENTE RIJSWIJK
7944	EVOS	NS RAILINFRATRUST BV
7945	VE	NS RAILINFRATRUST BV
7946	VE	NS RAILINFRATRUST BV
7949	EVOS	NS RAILINFRATRUST BV
7949	OS	DE GEMEENTE RIJSWIJK

VE = full right of ownership; OS = right of superficies;

EVOS = right of ownership, restricted by a right of superficies

In this area there is:

- a railway station building, owned by NS Vastgoed BV (parcel 7856 whole parcel column; 7857 ground level)
- a railway tunnel, and platforms owned by NS Railinfratrust BV (parcel 7854, 7855, 7857, 7944, 7949 underground; 7945, 7946 whole parcel column)
- public space owned by *Gemeente Rijswijk* (7944, 7949 ground level)
- a kiosk, owned by NS Vastgoed BV (7855 and 7854 ground level)

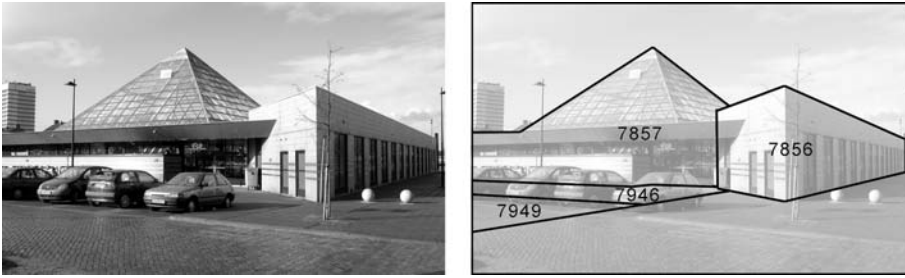

Figure 3.8: *The location of parcels around the building of the railway station.*

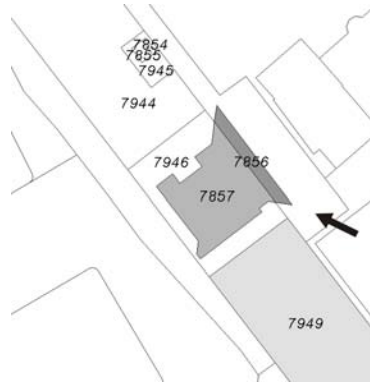

Figure 3.9: *Fragmented pattern of parcels caused by the projection of 3D objects on the surface. The arrow indicates the position of the camera in figure 3.8.*

In figure 3.7 the pyramid-shape object is the building of the railway station (parcels 7856 and 7857), the building on the right is a kiosk (parcels 7854 and 7855) and the railway tunnel is located beneath the buildings.

The cadastral map and the photo of figure 3.8 show that the station building, owned by NS Vastgoed, has been built for the major part above the tunnel (assuming that the tunnel is located below the surface parcel 7857) and for a relatively small part next to the tunnel (parcel 7856). For the first part NS Vastgoed holds a right of superficies on the parcel owned by NS Railinfratruster BV, for the second part NS Vastgoed has the full ownership of the parcel. This case also shows that the 3D spatial extent of rights is not available in the cadastral registration, although it is possible to see that more than one person is entitled to a parcel.

This example is a good illustration of how 3D physical objects below and above the ground control the parcel pattern in the cadastral map (e.g. 7856 and 7857 for the railway station building, also the tunnel is identifiable in the patterns of parcels). Moreover 3D physical objects are “divided” into parts according to the parcel boundaries on the surface. The cadastral map on this location reflects the basic principle of the current cadastre, i.e. registering rights on 2D parcels.

### 3.2.2 Case study 5: Railway tunnel in rural area

In the Netherlands the Paris-Amsterdam High Speed Railway (figure 3.10) is currently under construction (planned to be finished in 2007). Since this railway is passing through unaffected rural land, it was decided to drill a tunnel for this part of the railway. The project team of the tunnel provided us with 3D data for the tunnel, which we then imported as one spatial object (a linear object) into the cadastral DBMS. Therefore it was possible to query the legal status of the intersecting parcels. Normally this is not possible since physical objects are not maintained within the cadastral registration. The tunnel itself is about 15 metres in width and 8.5 kilometers long: 7,160 meters for the actual drilled tunnel and two entrance sections of 660 meters and 770 meters in length.

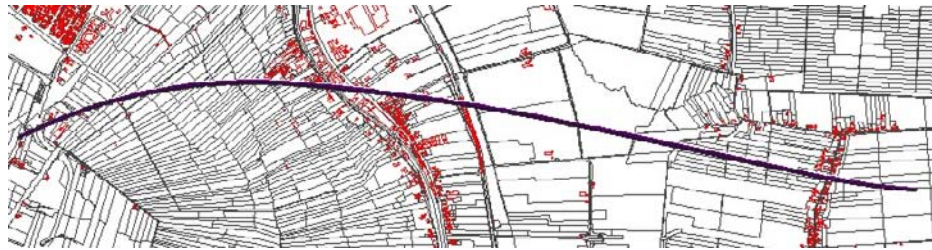

Figure 3.10: *The railway tunnel in the “Green Heart” of the Netherlands.*

In November 2001 the activities for this tunnel started. The drilling of the tunnel was completed in January 2004. We had access to three snapshots of the cadastral database: June 2000, June 2001 and September 2003. Between June 2000 and September 2003, most of the property rights needed by the Ministry of Transport and Public Works were obtained and registered. For this reason we were able to study the differences in the legal status of the parcels that contain the tunnel between the different snapshots. The results of this investigation are shown in table 3.1.

As can be concluded from this table, at the location of the planned tunnel many changes have taken place between June 2000 and September 2003. Of the original 104 (complete) parcels that intersected with the tunnel in June 2000, 36 are not subdivided in September 2003 (and 50 were not subdivided in June 2001). The other 68 parcels (and 54 in June 2001) are subdivided (without being surveyed yet) because the tunnel has been built just below a part of these parcels. The subdivision of parcels avoids that part of parcels that do not intersect with the tunnel are encumbered with a right for the tunnel. Most of the subdivided parcels are divided into two parts. A minority of them are divided in three, or even four new parcels.

Of the 104 intersecting parcels, in June 2000 the Ministry of Transport and Public Works had a right on 12 intersecting parcels which are all ownership rights. In June 2001, the Ministry had a right on 80 intersecting parcels; 44 ownership rights and 36 rights of superficies. Finally in September 2003, the Ministry had a right on 99 intersecting parcels; 47 ownership rights and 52 rights of superficies. All intersecting parcels affected with a right of superficies are also affected with the legal notification ‘OB’ (underground construction), with the Ministry as subject. In the snapshot of

	June 2000	June 2001	September 2003
1.Number of parcels intersecting with the projection of the tunnel	104	104	104
2.Number of intersecting parcels that contains part parcels	0	54	68
3.Number of parcels of (1) that is encumbered with a right that belongs to the Ministry of Transport and Public Works	12	80	99
4.Number of parcels (including part parcels) that is encumbered with a right that belongs to the Ministry of Transport and Public Works	12	91	121
5.Number of rights mentioned in (3) that is a right of ownership	12	44	47
6.Number of rights mentioned in (3) that is a right of superficies	0	36	52
6a.Number of parcels affected with an 'OB' notification	0	36	52
7.Number of rights mentioned in (4) that is a right of ownership (registered both on part parcels and complete parcels)	12	53	60
8.Number of rights mentioned in (4) that is a right of superficies (all registered on part parcels)	0	38	61

Table 3.1: *Results of the queries on the legal status of the parcels intersecting with the railway tunnel passing through the 'Green Heart' of the Netherlands.*

June 2000, none of the intersecting parcels had an 'OB' notification.

The results based on the cadastral database of September 2003 show that at that moment the Ministry still had to obtain a right on five intersecting parcels.

### 3.2.3 Case study 6: Utility pipelines

A Dutch company owning an important network of utility pipelines (hereafter: the "Company") provided us with 3D information on two pipelines in a rural area. We imported this data into the cadastral DBMS. Therefore it was possible to query the legal status of the intersecting parcels (see also [135]). The lengths of the pipelines are approximately 4 and 6.5 kilometres. We queried the legal status of the pipelines with a copy of the cadastral database of June 2001. The querying was again based on both spatial and administrative information. The results of the querying are shown in table 3.2. Registration of these pipelines will change as will be described at the end of this section. First of all we can conclude that not all parcels crossed by the two pipelines have the legal notification referring to a right held by the Company. In total 42 parcels are intersecting pipeline 1, of which 27 parcels have a legal notification and one parcel has a right of superficies for the pipeline, registered as such (and not as a special case of right of superficies for a pipeline, AKR code 'OL'). In total 43 parcels are intersecting pipeline 2, of which 38 parcels have a legal notification with the Company as subject. Another query showed that some of the "non affected" parcels are in full ownership of the Dutch government. In these cases a public law

*permit* is sufficient. In most cases this is not registered in the cadastre. Recently a project was started to register those permits as well. Additionally two privately owned parcels intersecting with the pipelines do not have a legal notification (see figure 3.11). A possible explanation can be that the Company has a personal right to use the land (short lease). The personal right of short lease cannot be registered in the cadastre (article 17 of Book 3 of the Dutch Civil Code).

	Pipeline 1	Pipeline 2
1.Number of parcels intersecting with the projection of the pipeline	42	43
2.Number of parcels of (1) that is encumbered with a right of superficies held by the Company	1	0
3.Number of parcels of (1) that is encumbered with a right of full ownership held by the Company	0	0
4.Number of intersecting parcels (including part of parcels) that has a legal notification with the Company as subject	27	38
5.Legal notifications of 4	mainly BZ(D)	mainly OL(D)

Table 3.2: *Results of the queries on the two pipelines of the Company.*

This case study reveals some complexities of current registration.

- The information that can be obtained from the cadastre is fragmented since only the rights on the intersecting parcels are registered. It is not possible to query the pipeline itself.
- The location of the pipeline itself is not registered. Even if a right has been established allowing the Company to build and hold a pipeline on a parcel (e.g. with the legal notification ‘OL’), the exact location of the pipeline (in 2D and 3D) is not known.
- A drawback of the cadastral registration of pipelines (and other cross-boundary objects) is that there is redundancy: for every parcel crossed by the pipeline, a reference is made to the same subject (holder of the pipeline), which may result in inconsistencies.
- Cadastral registration of infrastructure objects is not uniform. OL(D), BZ(D), OS (right of superficies), short lease are all used to register the legal status of pipelines (and even personal right of short lease, which is not registered in the cadastral registration). It should be noted that OL(D), BZ(D) and OS are different codes in the cadastral registration and all refer to exactly the same right (i.e. right of superficies in case of a pipeline), which is obviously confusing.
- Another complication is a ‘BZ’ or ‘OL’ notification instead of a ‘BZD’ or ‘OLD’ notification. The ‘D’, indicates that the right in rem is established on just a part of the parcel. The deed in which this notification is established contains information about the location of the pipeline. When a parcel is subdivided the notary (in the Netherlands a publicly appointed official charged with drawing up authentic deeds and legalising documents) is obliged to perform further examination to the exact location of the pipeline where a ‘BZD’ or ‘OLD’ is used. When a ‘BZ’ or ‘OL’ is used, the notary will not do this examination which results in an establishment of the legal notification on all the new parcels that were created on the location of the original parcel, even on parcels that do not intersect the pipeline.



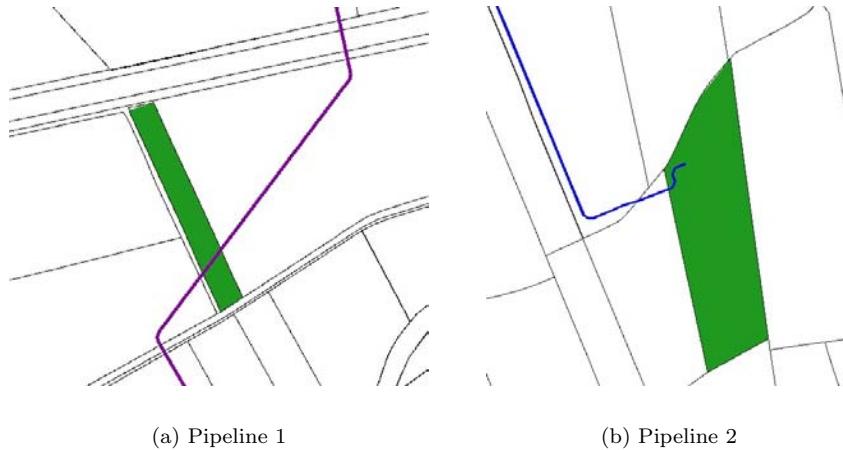

Figure 3.11: *Intersecting parcels (privately owned) with no cadastral recording.*

The Company had met the same complications (parcels that intersect with a pipeline without a restriction, but also parcels that do not intersect with a pipeline of the Company with a restriction). Therefore, in 2000, the Company started an action in collaboration with the Netherlands' Kadaster to clean up the registration. In April 2003 they finished one province (Drenthe). For this province, all parcels intersecting with a pipeline of the Company have been manually examined. For all parcels intersecting with the Company's pipelines for which nothing was registered in the cadastral registration, action was undertaken to improve cadastral registration. For example when a public law permit was used for a parcel (not registered in the cadastral registration) in the new situation an 'OB' code has been registered for that parcel. With this notification it is now possible to see that something is located below the intersecting parcel. The subject of the 'OB' code is the Company. It will be a challenge to keep the registration clear after subdividing parcels. Since the clean up action of this first province yielded good results, the other provinces will also be cleaned up. A new query in the future will therefore show other (better, more complete, clean) results. This case shows the complications for other utility companies that could learn from the action that was undertaken by the Company.

### 3.3 Conclusions

In this chapter six case studies concerning cadastral registration of 3D situations were described. The case studies were carried out in order to get an overview of the actual needs and requirements for a 3D cadastre.

#### **Cadastral registration of building complexes**

The first three cases illustrate the cadastral registration of 3D property situations that mainly occur in urban areas: multifunctional building complexes. Stratified property in building complexes is registered by means of all kinds of (limited) rights on the

ground parcel(s): right of superficies, apartment rights, right of easement. Consequently there is no uniform cadastral registration for stratified property in building complexes. In the current registration one can only see which persons have a right on the ground parcel(s), but the 3D extent of rights is not registered (what is the space to which a right applies?). The (2D and 3D) extent of property units in buildings is not visible on the cadastral map. Also administrative information on the property unit itself is not available in the cadastral registration, except in case of apartment rights (each apartment unit has at least an id). The Public Registers can be consulted to get insight into the actual 3D situation only in case of apartment rights. However, the overviews of apartment complexes added to deeds are paper or scanned drawings, which are not and cannot be integrated with the cadastral geographical data set. In other cases such as establishing a right of superficies, adding plans to deeds is voluntary. Consequently consulting the Public Registers does not necessarily yield more information. Since deeds will soon be available in scanned format, the deeds (and thus the drawings added to deeds) can be accessed directly from the cadastral database through a link. This will offer better accessibility of information in 3D situations, especially in the case of apartment complexes.

### **Cadastral registration of infrastructure objects**

The legal status of infrastructure objects is established by means of limited rights (mostly right of superficies) and legal notifications established on intersecting parcels. Information on a 3D physical object itself (with a 2D or 3D description) is not available because no unique id for infrastructure objects is maintained in the cadastral registration. Also the limited rights and legal notifications established for the objects are not related to a spatial description. Therefore we cannot find out where infrastructure objects are located in the 2D cadastral map and if the objects are located above, on or below the surface. The current cadastral recording of infrastructure objects leads to a fragmented pattern of parcels, while the 3D object is divided into parts in order to let them match with surface parcels. The limited rights and legal notifications are not linked to infrastructure objects in the real world, but to the holders of infrastructure objects. The reference to the holder of the infrastructure object is repeated for every intersecting parcel, which leads to redundancy and to potential inconsistencies.

The type of rights used to establish the legal status of infrastructure objects is also not uniform, since several methods were found for establishing the legal status of infrastructure objects. It is also possible that a holder of an infrastructure object has a personal right to use the land (short lease) or that the owner of an infrastructure object is the same as the owner of a parcel (e.g. both governmental bodies). In these cases no information on the 3D situation can be found at all in the cadastral registration.

In the case studies described in this chapter, we were able to perform queries such as ‘which parcels intersect with this infrastructure object’ since the holders of the infrastructure objects used in the case studies provided us with 3D information on the infrastructure objects. However, this query is not possible within the current cadastral registration as the infrastructure objects themselves are not available within the cadastre.

## Chapter 4

# 3D cadastre abroad

Countries throughout the world have experienced an increased pressure on land which has led to multilevel property. Since individualisation of property started originally with a subdivision of land using 2D boundaries causing a 2D parcel to be the base cadastral registration unit, cadastres will have to find solutions to deal with 3D property situations. Therefore, an indispensable question in this research is how do other countries deal with 3D situations, concerning legal, technical as well as organisational aspects and can we learn from other countries?

In this chapter we will have a closer look at 3D cadastral issues in six selected countries and states: Denmark, Norway, Sweden, Queensland (Australia), British Columbia (Canada) and Israel (section 4.3 to section 4.8). The reason for selecting these countries is either that the discussion on 3D cadastral issues has already started in these countries or that these countries have introduced solutions that solve (part of) the problem of 3D cadastral registration. To be able to compare the results of these international studies with the Netherlands, first the Dutch situation is summarised in section 4.2.

This chapter uses the results of the international workshop on 3D Cadastres that was organised in Delft, November 2001 as part of this research [142]. The international discussion that was started during this workshop, was continued at the FIG congress in April 2002 in Washington and at the FIG Working Weeks in April 2003 in Paris and in May 2004 in Athens during special sessions on 3D cadastres. The results of these meetings are completed with results that were obtained by literature study and by case studies that were carried out in Denmark and Queensland, Australia.

This chapter starts with an introduction on 3D cadastral registrations abroad and ends with conclusions.

### 4.1 3D cadastral registrations abroad

Countries throughout the world are confronted with the complexity of cadastral registration of 3D property situations. Developments to face and solve these problems

depend on the national legal system and the state of the art of the cadastral registration in the specific country.

Third world countries are still in the phase of getting the 2D cadastre up-to-date, let alone worrying about 3D registration. Additionally the type of cadastral registration as described in section 2.1, has its influence on how 3D situations are registered. Countries with a cadastral registration financially supported by the government (unlike the Netherlands) will be less motivated to take care of changing user requirements unless the government is an important user itself. However, if a government guarantees title there is also a strong motivation to take all possible steps to ensure changing requirements are taken care of. Another factor that seems to influence the discussion on 3D registration is the basis of the legal system. For example, in the Netherlands the concept of property rights to real estate is still land (surface) oriented, while other countries, as will be seen in this chapter, have dissolved the complications of 3D cadastral registration at the juridical level. The legal system in these countries provided the possibility to establish multilevel ownership no longer related to surface parcels.

In most countries apartment rights (condominium rights) or strata titles are used to establish 3D property units. The registration of apartment rights is different in every country. However, there are no cadastral registrations known in which the spatial extent of apartment units is registered (in 2D or 3D) as part of the cadastral geographical database.

Kenya, South Africa, Australia and England (basically all Common Law countries) use strata titles [191] in the case of 3D situations. Different terms (e.g. sections) are used in these countries for more or less the same concept. The land registration contains an analogue or scanned drawing of the situation. This drawing includes an overview of the complete parcel divided into individually owned units and common property, augmented by the cross sections of the different buildings (figure 4.1). These drawings are not incorporated in cadastral registrations.

Other international solutions to establish 3D situations involve the right of superficies or the use of easements. These rights can be spatially defined in titles or deeds by means of plans and cross sections, and in some countries also in 2D on the cadastral map (e.g. Australia, Denmark). However, no cadastral registration has been found that is able to reflect the third dimension of rights as part of the cadastral geographical data set.

The disadvantage of the solutions to register 3D property units in current cadastral registration, is that the 3D information is not integrated in the spatial part of the cadastral database (only available in titles, survey plans and/or deeds). It is for example not possible to see the 3D situations of two neighbouring parcels in one visualisation. Also querying the 3D situation ('who is owner of this stratum') is not possible. The 3D drawing in the land registration is just a (2D) visualisation of the 3D situation. Therefore it is not possible to view the 3D situation interactively.

The discussion on 3D registration has started in many countries as can be concluded from the workshop in Delft, 2001, that attracted eighty participants from twenty-seven countries. Additionally the establishment of 3D property units with separate ownership apart from the traditional ownership of 2D parcels is already practised in

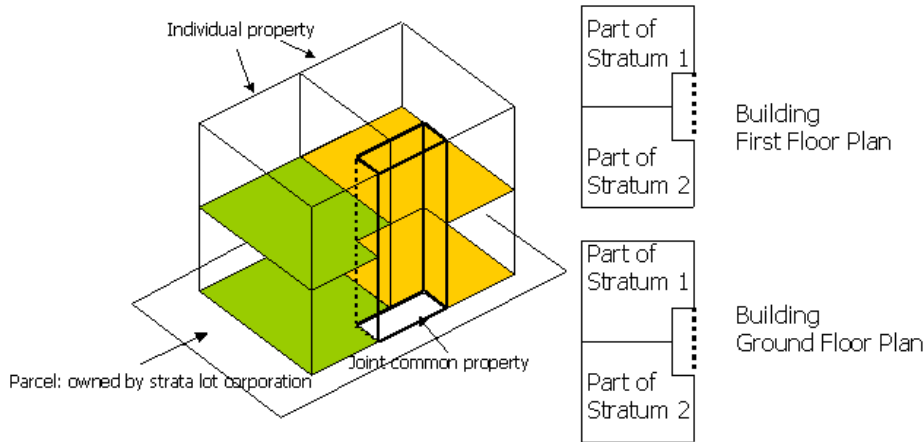

Figure 4.1: *Example of drawing in strata title (by courtesy of Michael Barry).*

some countries. However the international discussion on 3D cadastres is a very complex one, since every country has its own specific problems concerning 3D registration and also its own specific juridical and cadastral framework (dependent on the historical background) within which they have to face the problem of 3D registration. 3D cadastral issues of six countries and states were studied: Denmark, Norway, Sweden, Queensland (Australia), British Columbia (Canada), and Israel. The aim of these studies was to illustrate the country-specificity of the discussion on 3D cadastres, to streamline the international discussion on 3D cadastres and to see if this research can learn from experiences abroad. From the experiences in the described countries it can be concluded that several countries have been able to solve some aspects of 3D cadastral registration, although the approaches differ. The main drawback of these solutions is that they all lack a fundamental approach by taking the juridical, the cadastral as well as the technical framework into consideration: the solutions that were found mainly focus on the juridical aspects. Another important conclusion from the experiences abroad is that it is impossible to talk about *the* complications of 3D cadastral registration and it is also hard to talk with people from different countries about *the* 3D cadastre, since persons from different countries may use similar terms with (slightly) different meanings.

The remainder of this chapter will describe the results of the studies on the six countries and states. It was examined if the specific country has faced the 3D cadastral problem, and if so, how it has faced the problem. When establishing a 3D cadastral registration, several phases can be distinguished. 3D cadastral registration starts with the ability to establish 3D property units within the juridical framework. The next step is to provide insight into the 3D property units, e.g. by drawings included in the land registration (which is the Public Register describing interests in land) or, even better, by integrating the 3D information in the cadastral registration (which links

the essential information from documents recorded in the land registration to geometry of real estate objects). In a final phase, regulations could be laid down, which define how to prepare and structure the 3D information that is used to maintain 3D property units in the land registration and/or the cadastral registration.

The different countries have been assessed by examining the following questions:

- How can 3D property units be established within the existing juridical framework?
- What was the main trigger to establish 3D property units or to start the discussion on how to establish 3D property units?
- Do 3D property units exist as independent properties in the land registration?
- Do 3D property units exist as independent properties (with 3D geometry) in the cadastral registration, and if so, how (e.g. with link to 3D geometry or integrated in cadastral geographical data set)?
- What are the main shortcomings of current registration of 3D property situations?

To be able to compare 3D cadastral registration abroad, the questions will be first answered for the Dutch situation.

## 4.2 Evaluating 3D cadastral issues in the Netherlands

*How can 3D property units be established within the existing juridical framework?*

Property rights in the Netherlands always have to relate to surface parcels. Consequently, the ownership of real estate is always established on surface parcels. Owners can be restricted in using the whole parcel column by limited rights or a parcel column can be divided into different property units by apartment rights (which are also related to the surface parcel).

*What was the main trigger to establish 3D property units or to start the discussion on how to establish 3D property units?*

The discussion in the Netherlands was started since a few 3D property situations were met that could not be registered unambiguously in current cadastral registration. In addition, the current registration cannot provide sufficient information in case of 3D property situations, as can also be concluded from chapter 2 and 3.

*Do 3D property units exist as independent properties in the land registration?*

3D property units do not exist independently in the land registration, but are always related to 2D parcels. The only exception is an apartment unit which is known as an individual property unit in the land registration. However also an apartment unit must always relate to one or more 2D parcel(s). Information on 3D property units can only be obtained by querying deeds that establish real rights on surface parcels.

*Do 3D property units exist as independent properties in the cadastral registration?*

Only in the case of apartment rights, the 3D property units exist as separate real estate objects in the administrative part of the cadastral registration. Apart from

apartment units, the only real estate objects known in the Dutch cadastral registration are parcels. Since recently cables and pipelines meant for telecommunication can be registered in the cadastral database. However, these objects still need to be registered on a surface parcel (the anchor parcel). The outlines of subsurface objects can only be indicated in the topographic part of the cadastral database by using a specific classification and visibility code.

*What are the main shortcomings of current registration of 3D situations?*

The main shortcomings of Dutch cadastral registration in case of 3D property situations is that the 3D situation is projected on the surface and that the spatial extent of rights is not available in the cadastral registration. In addition, the real situation is not properly reflected in the cadastral registration, e.g. by showing (3D) outlines of physical constructions above and below the surface.

## 4.3 Denmark

A case study was carried out in Denmark during a working visit in Aalborg (November 2003) in collaboration with the Danish National Survey and Cadastre (*Kort & Matrikelstyrelsen*) and the 3D geo-information centre of Aalborg University. During the case study the issues of land registration and the cadastral registration with respect to 3D were studied. Two types of 3D property situations were further examined: apartment units and infrastructure objects crossing parcel boundaries. These case studies were examined in the same way as the case studies in the Netherlands. The case studies in Denmark are described in detail in [196] and [203].

The main findings of the study in Denmark are that two main aspects influence the discussion on 3D cadastral registration in this country:

- the organisation of real estate registration in Denmark;
- the lack of information on rights and subjects in the cadastral registration.

### Organisation of real property registration in Denmark

In Denmark there are four basic registrations of real properties falling under different authorities:

- Cadastral registration, maintained by the National Survey and Cadastre (KMS) which is an agency within the Ministry of Environment.
- Land registration (Land Book), which is a registration of property rights in real estate under the responsibility of the Ministry of Justice.
- Building and dwelling registration (BDR), maintained by municipalities (275 in total). The BDR contains information on three levels of registration:
  - property (related to buildings) which is the same property as registered in the cadastral registration;
  - building;
  - units.
- Valuation registration, also maintained by municipalities, to record valuation on single properties, which may themselves be units in the building and dwelling registration. The valuation registration assists authorities in calculating and

collecting property taxes. The Ministry of Economic and Business Affairs is responsible for both the building and dwelling registration and the valuation registration.

All these four registrations contain some information on real property objects. The entity ‘property’ in the land registration, the cadastral registration and the valuation registration refers to the same object: one or a collection of parcel(s), which is defined (in the cadastral registration) as one real property. However, the entity ‘property’ is separately maintained (different instances in different databases), while inter-relationships between the different databases are not digitally maintained. Property in the building and dwelling registration also refers to the ‘property’ entities in the other three registrations. However, this property is only registered when it is related to a building. The valuation registration divides the properties further into smaller property units. These property units can be:

- self-owned apartment units also registered as legal apartment units in the land registration;
- rented apartment units;
- apartment units in apartment complexes owned by a housing association.

In conclusion much information on real property is registered in Denmark. However, since registration of real property in Denmark is divided among different governmental bodies and since the definition of real property may slightly differ in the different registrations, the organisation of information on real property is complex. Consequently information on real property is not easily accessible, even in 2D situations. Information on the factual situation, both in 2D and 3D, would be better accessible if the different registrations were linked.

#### **Information available in the cadastral registration**

The cadastre in Denmark consists of four elements:

- a registration of real properties (*ejendom*) and land parcels;
- cadastral map;
- measurement sheets related to boundaries;
- registration of control points used for cadastral surveys.

However, the Danish cadastre does not contain any information on 3D situations:

- information on different types of land use on one parcel cannot be maintained: only the main use of a parcel is maintained;
- information on rights and subjects of rights on parcels is not maintained, with the exception of public restrictions (protected forest areas, dune protection zones, coast protection zones, polluted land parcels);
- the existence of an apartment cannot be known from the cadastral registration.

### **4.3.1 Evaluating 3D cadastral issues in Denmark**

*How can 3D property units be established within the existing juridical framework?*

In Denmark, real property is always related to surface parcels. Consequently, the



ownership of real estate is always established on surface parcels. Owners can be restricted in using the whole parcel column by easements or a parcel column can be divided into different property units by apartment rights.

*What was the main trigger to establish 3D property units or to start the discussion on how to establish 3D property units?*

In Denmark real estate is defined by surface parcels. Since this concept is a limiting factor for establishing and providing insight into the juridical situation in the case of 3D property situations, the question arose as to how to establish and register 3D property units.

*Do 3D property units exist as independent properties in the land registration?*

Limited rights and apartment rights are only known in the land registration. The legal documents that establish the title can be accompanied with drawings of the situation, but this is only obliged in case of direct (individually owned) apartment units. In this case a drawing with an overview of the floor(s) is included in the document in which the apartment right is established. The apartment units in apartment complexes that are owned by one housing association cannot be known from the land registration.

*Do 3D property units exist as independent properties in the cadastral registration?*

Cadastral registration only contains a parcel register and a real property register. Rights and subjects to rights cannot be obtained from the cadastre. Therefore, even the current registration does not provide information on the establishment of more than one right (or restriction) on one parcel. The land registration always has to be queried to determine what rights are established on a parcel. In addition, apartment complexes are not known in the cadastre.

*What are the main shortcomings of current registration of 3D situations?*

In the current registrations of real property, information on the factual situation is not readily accessible, since information on real estate is maintained in four different registrations. Different registrations need to be queried to get insight into the juridical situation. In addition registrations of real rights and real property is separated: real rights are only recorded in the land registration while real properties are only recorded in the cadastral registration. Therefore, a first step is to bring the land registration and the cadastral registration together, which will make it simpler to determine what rights are established on a parcel and which persons have a right to a parcel. Reorganising registration of real property, which is the first step in improving the accessibility of information (both in 2D and 3D), requires decisions at the political level.

A Danish Geo-Information Infrastructure will support setting up an integrated data model of property registration at the conceptual level which makes it possible that the different registrations can communicate and that representations of the same real property can be interrelated with each other (see also section 5.3).

## 4.4 Norway

Norway has a solid subsurface in a geological sense, in contrast to the subsurface of the Netherlands which consists only of sediments. In Norway tunnels for roads,

trains, and water drilled in the subsurface do not influence the economic value of the surface property. Therefore these subsurface objects are already common practice in Norway without subdivision and formal registration in the cadastre and in the Land Book. The owners of surface properties are only compensated financially if the surface property has been damaged in any way.

At the beginning of the nineties, providing the possibility for 3D property was listed as an important motivation for the improvement of cadastral legislation in Norway, since the current juridical framework does not provide the establishment of 3D property units with separated ownership on one surface parcel. It was expected that investors would be more willing to invest money in registered ownership, than in all kinds of limited rights that are currently used to establish stratified property.

A committee was established in 1995 which concluded that three types of 3D property should be facilitated:

- volumes below the surface of the earth, such as underground parkings, shopping areas, tunnels;
- buildings and other constructions erected on pillars or by other means realised above the original surface of the earth, mostly above roads or railways;
- constructions on pillars at sea or fresh water.

The findings of the committee led to a proposal for a law on ‘*construction properties*’. It is assumed that this law will be enacted in 2006 [133]. In this law the surface property is still the basic property object including all land and permanently fixed constructions except what is subdivided from the surface property. It is expected that the chosen legal instruments will have effect on prices. A 3D construction property has the following characteristics:

- A 3D property construction can only be established by subdivision of the surface property and may cross several parcels.
- It is up to the parties involved to decide whether to use the 3D property construction solution or to use other possible solutions such as servitudes or to remain unregistered in the cadastre.
- The parties involved enjoy much freedom and carry the risk of making bad arrangements. It is expected that the new law will accept construction or building drawings as satisfactorily for registration, without additional surveying. Any detailed surveying of the 3D property beyond that level of accuracy would be the choice and responsibility of the parties involved.
- Since a new parcel can only be established when it follows the planning and building acts, a subdivision of a parcel in general is not permitted unless it is likely that the subsequent construction on the parcel is approved. This means that there is a direct link between the new parcel and the building to be created. 3D construction properties that will remain unused are prevented by this regulation. In addition the potential for speculation in land and in space is reduced. A 3D construction property will be approved when it is needed to support a particular and approved construction. Therefore, the law on 3D construction property inhibits the free construction of 3D property units.
- A 3D construction property will cease to exist should the actual construction to which it alludes collapse and not be rebuilt within three years.

- A 3D construction property can only be established when the surface can still be used for a relevant purpose as part of the property from which the construction property will be subdivided. Therefore a building standing directly on the surface cannot be established as a 3D construction property.
- A 3D construction property cannot be established for parts of buildings. It is only possible in the case of separate buildings in which the 3D properties have no relationship to the neighbouring properties beyond the usual relationship between neighbouring surface properties. In the other cases, apartment rights (*eierseksjon*) must be used, for example in the case where new units are part of a common owned building.

At this moment no specifications for surveying or solutions for the cadastre are part of the proposal. Conditions in this area would only delay the introduction of the law that meets the demand of the market. For the short-term future it is expected that the cadastre will accept rather simple solutions such as visualising the projection of the 3D property on the surface only, while referring to more detailed information contained in the deeds.

Awaiting the new law, the municipalities (which are the cadastral authorities at local level) have for many years established properties as volumes above and below the surface, subdividing the volume from the surface property. They have extended the existing cadastral law with municipal regulations to be able to divide properties in 3D. The proposed regulations are based on existing practices. An example of this practice is the municipality of Oslo. This city introduced a practical approach to register 3D properties as real property both in the cadastral registration and the title register [217]. These properties have the same rights and restrictions just as surface parcels. The existing law does not provide for these 3D real properties, and hence the Oslo method has mostly been limited to underground facilities. In the case of 2D subdivision, the new parcel boundaries are surveyed and marked. In the 3D case, it is impossible to survey before the actual construction has been built. Therefore, the plans and drawings from the applicant are sufficient. Usually, this drawing is also accepted as the final document against which a survey certificate is issued without any surveying. On the survey certificate each corner is given by coordinates and heights both at floor and ceiling level. The registration number and the survey identify the parcel as a volume, but in the various registers the parcels size is given in square meters and not in cubic metres. This is due to the Land Subdivision Act that has no provision for 3D parcels. A 3D parcel is identified by a unique parcel number. 3D parcels can be recognised because the parcel number ends with ‘300’. The numbering of the 3D parcels is done in such a way that the relationships with the surface parcel are preserved.

#### 4.4.1 Evaluating 3D cadastral issues in Norway

*How can 3D property units be established within the existing juridical framework?*

The new law will enable to establish 3D construction properties that may cross several surface parcel boundaries. Although such construction properties are not yet formally allowed, municipalities and the land registration already accept it, as was shown by the Oslo method.

*What was the main trigger to establish 3D property units or to start the discussion on how to establish 3D property units?*

Currently multilevel ownership can be established by apartment rights or just by virtue of the owner's legal right to use his property (unobstructed by legislation). In the latter case, the legal status is not established and not registered, which is always a risk, especially in case of constructions owned by private persons. Therefore it is required to ensure the legal status of real property in the cadastre. Apartment rights must always relate to a surface parcel on which the related building is erected, while the 3D construction properties are not necessarily related to the surface parcels. The 3D construction property enables 3D ownership for which apartment rights are not an appropriate solution. Examples include independent volumes below the surface crossing several parcels (underground garages, shopping areas, tunnels etc.), buildings and other constructions erected on pillars or by other means realised above the original surface frequently built above roads and railways.

*Do 3D property units exist as independent properties in the land registration?*

The 3D property units that will be established will be known in the land registration. However there are no requirements for surveying and mapping the 3D property unit. The 3D geometry of the property unit may therefore not be known (in detail) in the land registration.

*Do 3D property units exist as independent properties in the cadastral registration?*

The 3D property units exist in the administrative part of the cadastral registration. The footprint of 3D construction properties can be drawn in the cadastral map. However, the 3D geometry of the 3D property unit will not be maintained.

*What are the main shortcomings of current registration of 3D situations?*

The first shortcoming in Norway is that construction property has to relate to real constructions. Furthermore, the cadastral registration can be improved by firstly setting up regulations to survey 3D property units and secondly by solving the technical aspects of 3D cadastral registration which is "how to incorporate the 3D information in the cadastral map".

## 4.5 Sweden

Before January 2004 in Sweden the division of ownership was not possible in the third dimension. This has led to remarkable legal structures. For example the space for the Stockholm underground is granted through an easement. The dominant parcel to which the easements are linked is a small property formed for a lift shaft going down to the underground railway [114].

The need for 3D property has been influenced by the fact that apartment units in an apartment complex can only be owned totally, e.g. by one housing association. Each member in such association has a flat connected with his apartment and when his share is sold, the right to the flat follows with the purchase. So, each apartment owner may sell his net share of the co-operative association (*bostadsrätt*). Both the association and the member may take a loan secured as mortgage. However, the association loan can be secured in the land registration and then be related to the whole property,

while the member loan is secured in a register kept by the association and is then related to the membership. Difficulties can arise when two types of security are in the same property and then also when different types of use are combined in one building (e.g. apartment units and offices), since this requires different right holders as well as the possibility of mortgaging the parts separately. One of the problems is the non-transparency of the related information, since the property and mortgage information is maintained in different registers. The separation of the right holders would make the apartment units as well as the offices more attractive on the real estate market (the office property will no longer constrain the housing property and vice versa). Therefore, for financial and administrative reasons, there is a need to divide properties in such a way that the facilities or parts of them can be mortgaged separately and owned as separate properties.

In [91] and [114] a new law is described that facilitates 3D property units. The law came into force in January 2004 [208]. The law was prepared by a committee, appointed by the Swedish government in 1994 to investigate the potentials for solving the problems of different types of use in one building. The main conclusion of the committee was that the most appropriate solution would be the facility to establish 3D property similar to 2D property. 3D properties can then be mortgaged and information on the 3D properties will be accessible through the real property register. The main objection to the proposal was that the fundamental property concept should not be radically altered from 2D since the number of 3D properties will probably be small. Therefore the new 3D properties had to fit within the structure of 2D properties. The following criteria have been set up for 3D properties (*3D-fastighet, 3D-utrymme*):

- Title must be in perpetuity.
- Title shall, as far as possible, be independent of the (land) property within whose parcel column it is located and shall be separately transferable, without any simultaneous transfer of the surface land.
- A 3D property must be an object for credit; public authorities, credit providers and other outsiders shall be permitted to obtain information on the rights established on the property.
- The new rules should as far as possible be in accordance with the existing principles of real property law.
- The ultimate aim of 3D property formation is to create better opportunities for 3D property use and also to permit such properties to serve as security for the grant of credits.

Formation of 3D property is only permitted if it accommodates, or intends to accommodate, a building or other construction and if it is assured of the rights necessary to its appropriate use (e.g. rights to joint facilities, easements). To avoid empty, air-space property units, the 3D property has to relate to a real construction. When it relates to a construction to be built, the cadastral authority can set a deadline for the completion of the construction. Unlike in Norway a construction itself may be divided into different property units with this new law. This is also the main type of ownership situation that the new law aims to facilitate. However, a 3D property for housing purposes must contain at least five apartment units, which means that the new legislation does not afford scope for the creation of individual apartment ownership. The 3D property units may intersect boundaries of surface parcels.

The 3D property is registered in the real property register and therefore accessible by the public. The new law takes care only of the legal issues and then in the same way as 2D properties. The projection of the 3D property units is indicated on the cadastral map. Details describing the boundaries, like marks, are described in scanned files in the cadastral database. Therefore these files can be checked (separately from each other) in computers.

### 4.5.1 Evaluating 3D cadastral issues in Sweden

*How can 3D property units be established within the existing juridical framework?*

The new law enables the establishment of 3D property units that may cross several surface parcel boundaries.

*What was the main trigger to establish 3D property units or to start the discussion on how to establish 3D property units?*

The main problem of the existing juridical system is that parts of multifunctional building complexes cannot be mortgaged independently, which may discourage investors from investing in multi-purpose building complexes. In normal cases this is no problem as the situation is instead handled through tenant-ownership. However, in cases with mixed land use problems can arise. Since the new law prescribes that a 3D property unit should contain at least five individual apartment units, the mortgage of individual apartment owners can still not be registered in the cadastral registration.

*Do 3D property units exist as independent properties in the land registration?*

The 3D property units are registered in the land registration. However there are no requirements for surveying and mapping the 3D property units. The 3D geometry of the property unit may therefore not be known (in detail) in the land registration.

*Do 3D property units exist as independent properties in the cadastral registration?*

Although 3D property units are registered as independent property units in the administrative part of the cadastral registration, it is not yet clear how 3D property units will be documented as part of the cadastral geographical data set. Until now, it was not the goal of the Swedish legislator to regulate the way 3D property units are incorporated in the cadastral database. At this moment the footprint of 3D property units can be drawn on the cadastral map. This means that 3D property units are registered in the same way as 2D property units.

*What are the main shortcomings of current registration of 3D situations?*

As in Norway, the 3D property units have to relate to built constructions. Consequently, the 3D property units do not cover all 3D situations. Furthermore cadastral registration can be improved by setting up regulations to survey the 3D property units and by solving the technical aspects of 3D cadastral registration: for example how to incorporate the 3D information as part of the cadastral geographical data set.

## 4.6 Queensland, Australia

In Queensland, Australia, the 3D registration has also (partly) been solved.

Since 1997, it has been possible to create parcels defined with 3D geometries. The juridical framework of Queensland, which originated from Common Law, provided the possibility of establishing 3D property units (which can be both freehold and leasehold estates). However, the cadastre only includes the footprint of these 3D parcels on the cadastral map, and therefore the cadastral issue of 3D property units is not solved in Queensland.

The cadastral registration in Queensland will be described more extensively compared with the other states and countries. The cadastral registration in Queensland is used to illustrate in more detail the possibilities and constraints of a 3D cadastre in the case of a land registration that is already able to define parcels with a bounded volume. In section 4.6.1 the different types of parcels that can be established in Queensland are described. In section 4.6.2 a case study from practise will be introduced to show possibilities and constraints of current cadastral registration of a 3D situation in Queensland. Improvements of the cadastral recording of this case will be showed in chapter 12, where the prototypes developed as part of this research are applied to this case study. Section 4.6.3 evaluates the 3D cadastral issues in Queensland.

3D cadastral issues in Queensland have been studied in collaboration with Queensland Government, Department of Natural Resources, Mines and Energy (NRME).

#### 4.6.1 Restricted, building and volumetric parcels

According to the Land Title Act of Queensland [174], a standard parcel (defined in 2D, but implying the 3D column) is a lot (or a collection of lots) which are unlimited in height and depth. Apart from these ‘unrestricted’ parcels, four types of parcels with a 3D component are distinguished:

- building parcels, which are parcels that are generally defined by floors, walls and ceilings;
- restricted parcels, which are parcels restricted in height or depth by a defined distance above or below the surface or by a defined plane (restricted easements can also be restricted in height **and** depth). The boundaries of the restricted parcels must coincide with the boundaries of the surface parcel;
- volumetric parcels, which are parcels that are fully bounded by surfaces and are therefore independent of the 2D boundaries of the surface parcels;
- remainder parcels, which are parcels that remain after a volumetric parcel or building parcel have been subdivided out of it.

The ‘in strata’ parcels that were used before 1997 (and are not applied anymore) included both the volumetric parcels and the restricted parcels.

A standard parcel may be subdivided using three different formats of survey plans: standard, building or volumetric format. In the document “Registrar of titles, directions for the preparation of plans” [175] the conditions for the different plans are exactly described.

A standard format plan defines land using a horizontal plane and references to marks on the ground. A standard format plan is used for standard parcels, restricted parcels

and restricted easements. In case of standard parcels, the drawn parcel refers to the whole parcel column. Restricted parcels (which are restricted in height or depth) are also indicated on standard format plans by *values relative to the surface* (defining horizontal planes), or by a defined plane. For restricted easements, the vertical restriction shall be detailed on the plan with reference to the Australian Height Datum together with details of the Permanent Mark on which this is based (page 20 of [175]).

A building format plan defines land using the structural elements of a building, including floors, walls and ceilings (building parcels). A building format plan is used in situations similar to apartment units in the Netherlands. A parcel is subdivided into a minimum of two building units (lots) and a common property that is shared. The common property is linked to the units and not to the persons owning the units. Lot numbers in buildings shall be numeric and may be made up in the form FL, TFL or TL, where T is a tower number, F is a floor number and L is the lot number. The building format plan should include a main plan with the location of each building or structure with respect to the outer boundaries of the base parcel (i.e. the projection of the outermost walls of the building). This plan should include any sub-surface basements and a diagram of every level of the building showing the parcels and common property on that level (page 32 of [175]). The maximum amount of encroachment (the intersection of this building with any other parcel) permitted is limited to half the width of the wall (page 36 of [175]). Consequently “the boundary of a building format lot may not be projected beyond the boundaries of the base parcel”.

A volumetric format plan defines land using 3D points to identify the position, shape and dimensions of each bounding surface and is used to reflect volumetric parcels. A volumetric parcel is a parcel, which is fully limited by bounding surfaces (which may be other than vertical or horizontal) and are above, below or partly above and partly below the surface of the ground (compare with restricted parcels and notice the difference). Volumetric parcels are possible in Queensland under the Land Title Act since 1997. The use and purpose of volumetric parcels (not per se related to constructions e.g. for a panorama) are determined by the local government and other legislation. One volumetric parcel can intersect several surface parcels. All lines on a volumetric format plan are straight and all surfaces are flat unless explicitly stated otherwise, hence any surface which is mathematically definable (so that an intersection can be calculated) can be registered. The height used to define volumetric parcels cannot refer to above or below a depth from the surface (the height cannot be defined as relative height or depth) since “this is subject to change and not capable of mathematical definition” [175]. The corners of volumetric parcels should refer to existing structures or marks as much as possible. The vertices of the corners should be given in bearings and distances of existing cadastral corners and the height levels in the Australian Height Datum. Each volume shall be given an area, which is the area of its footprint, and a volume in cubic meters. The plan should show a 3D representation of the parcel. The 3D descriptions are maintained in titles in the land registration while a footprint of the volumetric parcel is shown on the cadastral map.

The cadastral geographic data set of Queensland has a “base layer”, which is a complete non-overlapping coverage, and consists of parcels, road, rail, watercourse and intersection parcels. An intersection parcel is part of a roadway (the intersection of two roads). Volumetric parcels are not part of the non-overlapping coverage, but the



footprints of these 3D parcels are drawn on the cadastral base layer and therefore they are overlapping with the base parcels. Also easements, having their own geometry (and survey plans), are drawn on the base layer and may therefore intersect several parcels. Initially easements are defined on a single base parcel, but the base parcel may get subdivided, leaving the easement whole. Building parcels are not drawn on the cadastral map.

#### 4.6.2 A case study in Queensland

Since volumetric and restricted parcels are advanced examples of 3D property units, a case study from practice will be used to illustrate the establishment of these parcels: the establishment of 3D property units for the Gabba Cricket stadium in Brisbane. This stadium overlaps two streets: Vulture Street in the north and Stanley Street in the south (see figure 4.2).

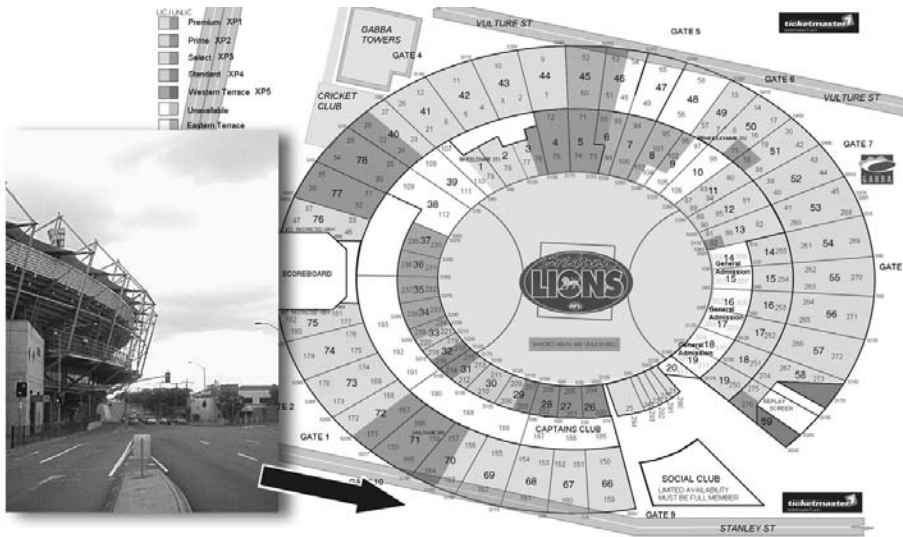

Figure 4.2: Overview of Gabba Stadium overhanging Stanley Street in the south and Vulture Street in the north, Brisbane, Australia.

Three 3D properties have been established: for the intersection with Vulture Street a stratum with parcel identifier 100 (established before 1997) and a volumetric parcel with identifier 101 and for the intersection with Stanley Street a volumetric parcel with identifier 103. The volumetric parcels were established after 1997. All three parcels are leasehold estates. This means that the holder of the real estate has the right of use and exclusive possession of the property for a specified time, which is comparable to the right of long lease (*erfpacht*) in the Netherlands. However, it should be noted that most volumetric parcels are related to freehold estates.

The titles establishing the 3D parcels contain very detailed 3D information imposed by the regulations: cross sections are added in case of the strata title and 3D diagrams

are added in the titles for the volumetric parcels (see figure 4.3 for parcels 101 and 103). All coordinates that are needed to demarcate the 3D property are present in the titles in bearings and distances. The coordinates are only determined when the information is entered into the cadastral database. The height of all coordinates is defined in the Australian Height Datum.

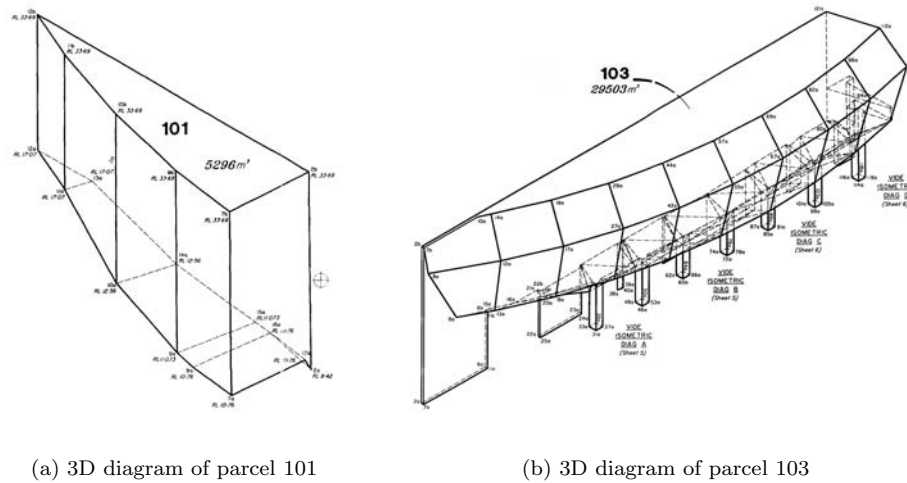

Figure 4.3: *Examples of 3D diagrams added to volumetric titles.*

The footprints of the 3D properties are part of the cadastral geographical data set. Figure 4.4 (a) shows the cadastral map with the footprints of the 3D parcels and figure 4.4 (b) shows the cadastral base map without the footprints of parcels 100, 101 and 103 (and without the geometry of easements). Figure 4.4 shows that 3D parcels are not part of the base parcel map and that volumetric parcels (and traditional strata parcels) exist separately from the base map and may therefore intersect parcels of the base parcel map. For example the 3D stratum parcel 100 crosses two parcels of the base map.

This example shows the very good potential for establishing 3D properties in the current registration in Queensland. How 3D information, which is part of survey plans and (volumetric) titles, could be used further to improve cadastral registration, will be explained in chapter 12, where the concepts developed as part of this thesis are applied to this case study in a prototype.

### 4.6.3 Evaluating 3D cadastral issues in Queensland

*How can 3D property units be established within the existing juridical framework?*

3D parcels (either bounded or unbounded) can be established. The way Queensland has solved the 3D property problem, shows that the law introduced in 1997 made it possible to establish 3D property units unrelated to the surface.



Figure 4.4: *Cadastral map on the location of the Gabba stadium, Brisbane, Australia.*

*What was the main trigger to establish 3D property units or to start the discussion on how to establish 3D property units?*

The existence of overlapping and interlocking constructions called for the ability to establish multilevel ownership. The legal system was extended to allow the establishment of 3D property units and the cadastral registration followed the legal practise.

*Do 3D property units exist as independent properties in the land registration?*

The 3D property units (bounded and unbounded parcels) are known in the land registration. The ‘Registrar of Titles directions for the preparation of plans’ dictates how to incorporate 3D information in survey plans. In case of restricted parcels, the projected parcels with values relative to the surface are sufficient, while volumetric survey plans require 3D diagrams, including values in the Australian Height Datum. It should be noted that the survey plans are (scanned) drawings. It is therefore not possible to view the volumetric parcels in an interactive 3D environment.

*Do 3D property units exist as independent properties in the cadastral registration?*

3D property units exist in the administrative part of cadastral registration. The footprint of the volumetric property is drawn on the cadastral map, and is therefore known in the cadastral registration. However, the 3D geometry is not available in the cadastral geographical data set, and therefore it is not possible to query the 3D situation from the cadastre, nor is it possible to see if two volumetric parcels overlap.

*What are the main shortcomings of current registration of 3D situations?*

Although, the titles contain detailed 3D information, the registration of the 3D properties meet some complications due to a number of reasons:

- Since the 3D information is laid down on paper (or scanned) drawings (which are 2D visualisations), the 3D information cannot be interactively viewed. This is a weak point because the ability to do so may be very helpful in case of complex volumetric parcels to interpret the situation correctly (e.g. parcel 103).
- The 3D properties are only described by coordinates and edges on drawings,

i.e. no 3D primitive is used. Therefore it is not possible to check if a valid 3D property has been established (is the 3D property closed, are the faces planar?).

- The 3D information is not integrated with the cadastral map or with other 3D information, e.g. two or more neighbouring parcels cannot be visualised in one view in 3D and it is also not possible to check how volumetric parcels spatially interact in 3D (overlap, touch etc.).

In Queensland, the basic improvement for 3D registration would therefore be to incorporate the information on 3D property units, which is already very well described in survey plans in the land registration, into the cadastral registration.

## 4.7 British Columbia, Canada

In British Columbia, Canada, an owner of a parcel has the right to subdivide his land into air-space parcels according to section 139 of the Land Title Act 1996 [16]. The air-space parcel may continue, or exist completely below the surface. Only the ‘fee simple estate’, which consists of all ownership rights that can be attached to a certain parcel (complete ownership), can be subdivided and not a leasehold estate (which is an estate created between a landlord and a tenant under a contract, comparable with the right of long lease in the Netherlands). For every subdivision, even in 2D, a subdivision plan has to be made. For air-space parcels a special part of the Land Title Act applies.

Every new 3D parcel (air-space parcel) has to be created within an existing conventional parcel. The grant of an air-space parcel does not transfer any easements or restrictive covenant that limits the use of the grantor’s land. The title to the ground below and to the air-space above and below the granted air-space parcel, as well as the easements and covenants remains the possession of the grantor. This means that an easement has to be created separately if access to the newly created air-parcel is desired or if the existing easements have to apply to the new air-space parcel as well.

The main requirement for creation of an air-space parcel is the provision of an air-space plan on the title [17]. This plan must consist of a 3D drawing to show that the boundaries lie within the boundaries of a single parcel (figure 4.5). This raises the question what will happen when the surface parcel is subdivided in the future. The plan must further indicate if it is a subdivision of the whole parcel shown on the plan or just a part thereof. A geodetic elevation (in the National Height Datum) is needed which must be noted on at least one of the corners of the parcel on the ground and for every corner or angle of the subdivided air-space parcel. Air-space parcels can be used for stratified property, but also for the purpose of later granting a right of view to benefit a parcel next to a planned construction [61].

For a further division of the air-space parcel, the rules of the Condominium Act applies. This divides the air-space into strata lots. The Condominium Act states that a building or land may be subdivided into strata lots by the provision of a building strata plan. The strata lots are coupled with an interest as a tenant in the remaining common areas. It is possible to establish either freehold or leasehold condominiums. The new strata lots have the same status as any land that is registered at the Land

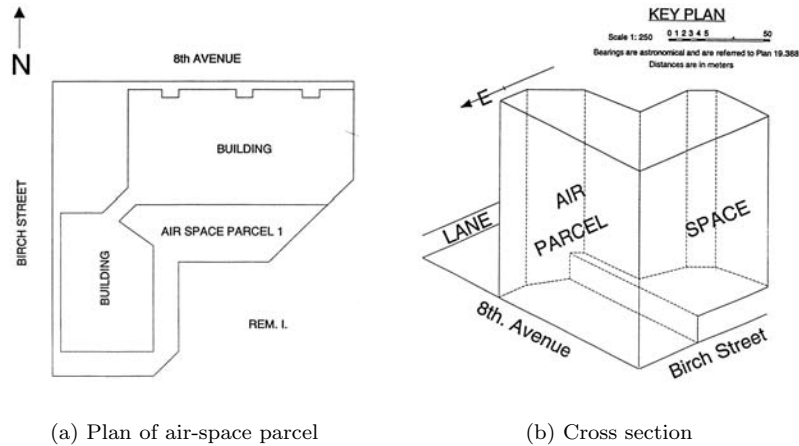

Figure 4.5: *Drawing in title of air-space parcel taken from [61].*

Title Office. The strata plan must contain a diagram of the proposed project, showing the boundaries of the land included in the strata plan and the location of the buildings.

In British Columbia the survey plans are registered in the Crown Land Registry and in the Land Titles Office. The Crown Land Registry lists all Crown land converted to private ownership, all private land turned over to the government, all existing Crown land tenures, leases, licences, or other time-limited holdings and includes maps that record the location of Crown land parcels. In British Columbia the Crown owns ninety percent of the land. The remaining ten percent is privately owned [61].

In the Land Title System, all titles are given a parcel identifier number, which is part of the legal description and should be included in all land titles documents. A registered title for a ‘fee simple estate’ can either be a conventional parcel or an air-space parcel, which are both considered as land under the Land Title Act. It can also be a part of the building, i.e. a strata lot according to the Condominium Act.

There is no general map which covers all existing parcels. There is only a plan that defines the specific area. Therefore information on the 3D (and 2D) properties can only be found in the land registration in the title documents. One has to look in the survey plans to get insight into the juridical situations.

#### 4.7.1 Evaluating 3D cadastral issues in British Columbia

*How can 3D property units be established within the existing juridical framework?*

3D property units with separate ownership within one parcel are allowed since it is possible to establish air-space parcels, apart from conventional parcels and apart from lots that are the results of subdivision under the Condominium Act. Air-space parcels may not intersect surface parcel boundaries.

*What was the main trigger to establish 3D property units or to start the discussion on how to establish 3D property units?*

As in the case of Queensland, the existence of overlapping and interlocking constructions called for the ability to establish multilevel ownership. Also in British Columbia the legal system was extended to establish 3D property units. The cadastral and land registration followed the legal practise.

*Do 3D property units exist as independent properties in the land registration?*

Air-space parcels are known as individual property units in the land registration. The 3D property situations are indicated with 3D diagrams in survey plans and can be known from the documents and records in the land registration.

*Do 3D property units exist as independent properties in the cadastral registration?*

In British Columbia, the cadastral registration is actually the land registration which includes a title registration. The survey plans are maintained as part of the titles. However there is no cadastral map in British Columbia. In 2D, neighbouring parcels cannot be integrated in one view, by which it is hard to get an overview of a certain situation and to see if two parcels overlap. Consequently, air-space parcels can also not be shown in one integrated view with other (air-space) parcels.

*What are the main shortcomings of current registration of 3D situations?*

Since 3D survey plans are prepared and available in a (more or less) similar way as in Queensland, basically the same shortcomings apply. In addition, 3D cadastral registration in British Columbia would be improved by two major steps. The first step is to make 2D survey plans digital and to create one parcel map out of the plans, with no overlaps and gaps in 2D. The second step is to make 3D survey plans digital (to be able to view the 3D property units interactively and to check the 3D property units) and to include the 3D information that is in detail available in survey plans in the digital cadastral data set. This would make it possible to query the air-space parcels in a combined view with the cadastral geographical data set.

## 4.8 Israel

Israel also faces high pressure on the use of land because some parts of it are intensively used. This has promoted developments of a 3D cadastre. At this moment, in Israel the 3D cadastral issue is only a topic of research. Since the research on 3D cadastre also started in Israel, this country was included in the study on 3D cadastre abroad.

The Survey of Israel has started a research and development project into the registration of the rights of land in three dimensions. This plan has an interdisciplinary approach in which legal, technical, as well as organisational aspects are considered [57, 58].

In the city transportation centre of Modi'in a large project has started including buildings, roads, tunnels, a railway station, bus station and more. This project has been used to examine the current land registration in Israel, and is now used to study the possibilities for 3D registration [63]. In [64] a case study is described in which 3D volumes were modelled for an underground parking in order to register rights for the parking. A precise 3D CAD model was constructed and intersected with surface

parcels leading to a spatial division of the 3D object. The aim of the model was to prepare a plan for registration of rights in 3D.

At the Geodetic Engineering Division of the Technion-Israel Institute of Technology a research is carried out in order to find a cadastral solution for utilising space above and below the surface and for defining the characteristics of a future 3D cadastre that will replace the existing 2D geographical surface cadastre in Israel. In the research many alternatives for a 3D cadastre have been defined based on different classifications. The defined alternatives will be studied into more detail in future research. The classifications do not yet take into account considerations for conceptual modelling of a 3D cadastre. The classifications that are distinguished in the research are based on different criteria and include the following topics (the terms used for these alternatives are based on [9]):

- multilayer information management models;
- alternatives for registering multilevel properties by using existing tools;
- 3D cadastral mapping;
- conceptual definition of the spatial parcel boundary;
- land settlement for 3D cadastre;
- restriction of current parcel column;
- 3D cadastral database: hybrid or integrated system;
- measuring of needed 3D data.

A list of criteria has been set-up, such as costs, feasibility, flexibility, continuity, and quality in order to assess the different alternatives. The design of a conceptual model for a 3D cadastre will be the next step after the best alternative has been chosen.

### 4.8.1 Evaluating 3D cadastral issues in Israel

*How can 3D property units be established within the existing juridical framework?*

At this moment 3D property units can be established in Israel in the same way as in the Netherlands. By establishing limited real rights on surface parcels, subdivision of the parcel column is possible.

*Do 3D property units exist as independent properties in the land registration or the cadastral registration?*

Also in Israel the 3D property units do not exist independently in the land registration or in the cadastral registration. Information on 3D property situations can be obtained when looking at drawings that are included in legal documents in which real rights are established.

*What was the main trigger to establish 3D property units or to start the discussion on how to establish 3D property units?*

Intensive use of some parts of Israel has led to overlapping and interlocking constructions. Since the right of ownership in Israel is not explicitly bounded in the third dimension and since this concept of ownership cannot easily be changed within the juridical framework, the question arose as to how to maintain and provide insight into the legal status of 3D property situations.

*What are the main shortcomings of current registration of 3D situations?*

Since the land registration and the cadastral registration maintain information on 3D property situations comparable to the Dutch registration, the main complications of current situations in Israel are similar as the complications that are met in the Netherlands (see chapter 2 and chapter 3).

## 4.9 Conclusions

Many countries have met the problems of registering 3D situations within current cadastral registrations which were originally developed to register the legal status of 2D parcels. The developments on 3D cadastral registration depend on the national legal system, on the state of the art of the cadastral registration as well as on the type of cadastral registration. For example, the main objective of many (less developed) countries is to get their 2D cadastral registration up-to-date, which means they do not bother (yet) with 3D registration. Apartment rights or strata titles, right of superficies and servitudes are used world-wide to establish stratified property, although no cadastral registration exists that reflects the 3D characteristics of these 3D property units as part of the cadastral geographical data set. All these rights and limited rights are still related to surface parcels.

This chapter presented the 3D cadastral issues in six countries and states: Denmark, Norway, Sweden, Queensland (Australia), British Columbia (Canada) and Israel. From these studies it can be concluded that no complete solution exists for 3D cadastral registration.

In Denmark the separate registrations of real property in the land registration and of real estate in the cadastral registration makes it already difficult to check the legal status of 2D situations. Therefore, the first step towards a 3D cadastre requires linking the land registration and the cadastral registration more closely together, allowing both registrations to access the information of each other. Some countries are, or will be soon, able to establish 3D property units with multilevel ownership no longer related to surface parcels within the existing juridical framework (with some extensions): Norway, Sweden, Queensland and British Columbia. These solutions differ per country, e.g. the footprints of 3D property units are limited to the 2D surface parcels (British Columbia) or not (Norway, Sweden, Queensland), the 3D property units have to relate to built constructions (Norway, Sweden) or not (British Columbia, Queensland), the 3D property units have to be described in survey plans (British Columbia, Queensland) or not (Norway, Sweden).

As can be concluded from this chapter, none of these solutions is a complete solution for 3D cadastral registration. Firstly, a digital description of the 3D property unit in vector format is not maintained (only scanned or paper drawings) in the land registration. Therefore, the 3D property unit cannot be viewed interactively and the geometry of the 3D property unit cannot be checked. Secondly, the 3D properties are still not incorporated in 3D in the geographical data set of the cadastral registration, hence it is not possible to query the 3D situation. The 3D property units are incorporated into the cadastral data set in the same way as 2D properties (as footprints). These solutions therefore do not address technical issues, such as how to store, query



and visualise 3D property objects (in 3D) and how to make sure that 3D properties do not overlap (the condition that 2D parcels may not overlap assures complete and consistent registration in current cadastres).

Although the examples of establishing multilevel ownership show good potentials for a 3D cadastre, in some countries the step to register 3D properties that are no longer related to surface parcels may be too extensive for the short-term future. An introduction of multilevel ownership requires redefining the cadastral concept. It is dependent on the legal system if 3D property units that are no longer related to surface parcels are easily possible within the current juridical framework. In countries where the concept of ownership of real estate is still restricted to a surface parcel, the 3D cadastre either has to find solutions to improve cadastral registration using the concept of a surface parcel or has to reconsider the traditional concept of ownership.



## Chapter 5

# Needs and opportunities for a 3D cadastre

The first part of this thesis focused on the basic question ‘what are the needs for a 3D cadastre’. Therefore first an inventory was made of types of Dutch cadastral recordings with a possible 3D component (chapter 2). To show the complexities of current cadastral registration of 3D situations in the Netherlands, chapter 3 described six (national) case studies. Chapter 4 described international developments on 3D cadastral registration in order to see if this research on improving 3D cadastral registration in the Netherlands can benefit from experiences abroad.

The implementation of a 3D cadastre will only be successful if the considerations for the 3D cadastre reflect on the current cadastral framework. The current cadastral registration of 3D situations in the Netherlands will therefore be summarised in section 5.1.

The current cadastral registration meets complications in 3D situations, causing a need for a 3D cadastre. This chapter will elaborate on the findings of the first part of this thesis in order to see what the needs are for a 3D cadastre. In addition, this chapter will also describe the potentials for a 3D cadastre.

The complexities of current registration will be summarised in section 5.2. From the complexities, the basic needs for 3D cadastral registration can be deduced (section 5.3). A 3D cadastre offers other opportunities as well, as will be described in section 5.4. When looking at the opportunities of a 3D cadastre, it is relevant to look for applications outside the cadastral domain which may benefit from a 3D approach of cadastral registration and vice versa, directly (since 3D information can be interchanged) as well as indirectly (since they can learn from the experiences from each other). Section 5.5 will describe 3D applications outside the cadastral domain. This chapter will end with conclusions.

## 5.1 Current cadastral registration of 3D situations in the Netherlands

In Dutch practice the legal status of most 3D situations is secured using apartment rights or right of superficies established on surface parcels. In case of apartment rights spatial information is available in the land registration using the legally prescribed (paper or scanned) drawings including cross sections. Although not strictly 3D, a drawing of each vertical layer is provided. In case a right of superficies is established in general no drawings are available in the land registration. Only in case of apartment units, the 3D property unit is known in the (administrative part of the) cadastral registration. In both cases the 3D property unit is not incorporated (in 2D nor in 3D) in the spatial part of the cadastral registration, with the exception that outlines of underground objects can be inserted into the topographic part of the cadastral database (which is not part of the cadastral map) by using a specific classification and visibility code. The scanned drawings will soon be accessible through the cadastral registration.

Current cadastral registration of 3D situations can be accomplished by a notification in the cadastral registration specified with an ‘OB’ code (*Ondergronds Bouwwerk*: underground construction). Such a notification is registered on a parcel. The OB notification indicates that something is located below the surface, whereupon the user can do further examination in the land registration (see section 2.5). The legal documents recorded in the land registration describe which rights are established on the intersecting parcels and may be accompanied by a drawing. The OB code does not say anything about the legal status of the 3D property situation. In addition, this solution only covers constructions below the surface and covers therefore only part of the 3D situations. As was seen in section 2.5.3, many other types of cadastral registration (occurring in more than 2 million cadastral recordings in September 2003) may indicate a 3D situation as well.

The cadastral database of September 2003 showed 1532 occurrences of an OB code, while none of these situation was indicated in the cadastral geographical data set. Notaries have to get used to this new type of registration. They will only use it when it has public benefits to them or their customers (e.g. more legal security, less work). Further the OB code is not used in a uniform way. We selected the registered OB codes, grouped by the different (cadastral) municipalities. Note that in the Netherlands, the *notaris* (civil law notary) is a publicly appointed official charged with drawing up authentic deeds and legalising documents. He is also a legal specialist on real estate law and acts as such also as an advisor of parties involved in transactions.

The diagram in figure 5.1 shows the number of occurrences of an OB code (on the y-axis) per municipality (on the x-axis). Municipalities with no OB codes are not included. In total there are 1218 cadastral municipalities in the Netherlands of which 44 with one or more occurrence(s) of an OB code. The municipalities are ordered on the number of OB occurrences. These results show that four municipalities are responsible for 40 percent of the OB occurrences: Emmen, De Wijk, Dalen and Norg. In addition 28 municipalities of this list (responsible for 1386 OB recordings) are all situated within the cadastral district of the regional office of Assen (which is one of the

less dense populated parts of the Netherlands). From the fact that a spatial correlation is present in the registration of OB codes, while the high number of OB recordings does not correspond with a more frequent occurrence of underground constructions, it can be concluded that the registration of an OB code is strongly influenced by preferences of the parties involved and consequently that the registration of an OB code is not uniform. For both the person who is responsible for the registration of an OB code (mostly the notary) and the person who queries the cadastral registration, it is not unambiguously clear when an OB code is to be used. The subjects that are linked to the OB codes are too diverse to be able to conclude if for example the user of the volume below the surface influences the registration of OB codes (for example a company that owns a large network of pipelines in this area).

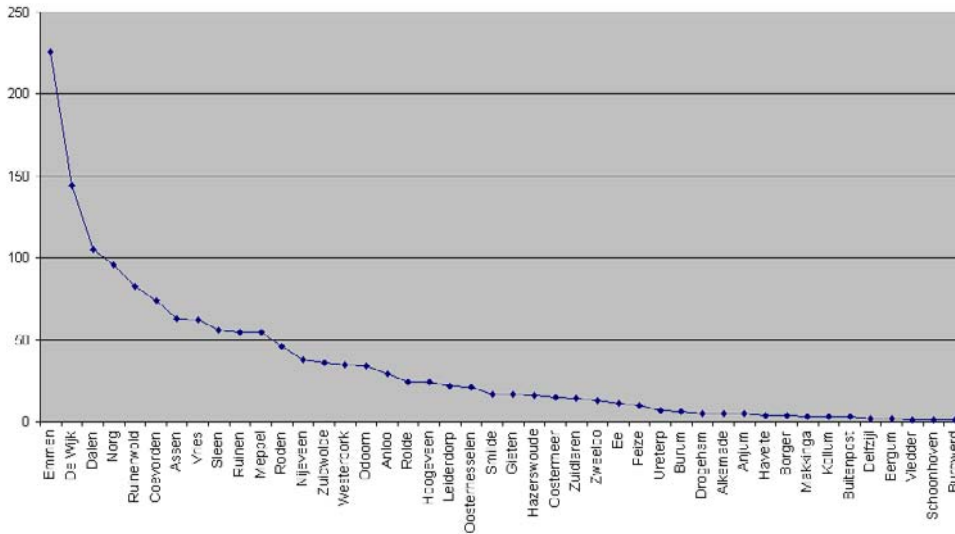

Figure 5.1: *The number of occurrences of an OB code per cadastral municipality.*

Not in all cases the establishment of special rights for underground objects is juridically necessary. Many underground situations relate to infrastructure where the owner of the parcel is also the owner of the subsurface object (e.g. a subway-tunnel under land owned by the municipality). In these cases no reference to a subsurface object is made at all in the deed, let alone that a drawing is provided. Consequently, this will also not lead to a cadastral recording of the situation. Other cases of underground constructions that do not lead to a cadastral recording are cases of not-registered personal rights (short lease), obligations to tolerate constructions for public good that follow from general laws and when nothing is registered.

## 5.2 Complexities of current cadastral registration

Requirements and developments of 3D cadastre are dependent on the type of cadastre as well as on the historical and juridical background of a specific country.

A study abroad showed that cadastral registrations in many countries are based on the same principle as the Dutch cadastral registration: a parcel is the basic registration entity for cadastral registration. This principle of cadastral registration follows the juridical definition of ownership of land. Ownership of land is defined by boundaries on the surface and is not explicitly limited in the vertical dimension. In general, the ownership of land includes all space above and below the parcel, as well as all constructions that are permanently fixed to the land. The consequence is that property to land is very well registered in the cadastral registration by means of 2D parcels, while 3D property units are established and registered by means of limited rights and other restrictions on intersecting parcels, i.e. an owner can be restricted in using the whole parcel column by establishing limited rights, apartment rights or Public Law restrictions.

Some other countries and states have redefined the unlimited ownership of a parcel. In these countries and states it has recently (or will soon) become possible to establish ownership rights related to bounded volumes by defining volumetric parcels (Queensland), air-space parcels (British Columbia) or 3D construction properties (Norway and Sweden). These 3D property units are the result of subdividing 2D parcels (or actually parcel columns). The solutions fit into the existing juridical framework of the specific country or only required small adjustments. The possibilities to establish multilevel ownership have not (yet) been translated into an appropriate cadastral registration of 3D property units. The 3D property units exist as independent properties in the land registration and are described on 3D survey plans. The 3D property units also exist as independent properties in the administrative part of the cadastral registration. However, it is impossible to view the 3D property units interactively (which is helpful to get insight into complex 3D property units) since the drawings are only available in scanned or paper format. In addition, consistency checks are not possible: are two 3D properties neighbours, is there a gap, is there overlap? Finally, the 3D properties are not available in 3D as part of the cadastral geographical data set.

### 5.2.1 Complexities of current Dutch cadastral registration

Although it is possible to register the legal status of 3D situations in the Netherlands administratively, the registration is not satisfactory, because of several reasons:

- The right itself is administrated, but not the function of the object to which the rights refer (underground infrastructure, metro station, subterranean parking place).
- 3D spatial information on rights (geometry, location) is not available, e.g. does the right of superficies apply to space above or below the surface?
- The administrative information (by means of restrictions and limited rights) may indicate that something *could* be located above or below the surface. As was seen in section 2.5.3 in September 2003, a total of about two million of such recordings were available in the cadastral database. However, this is the only information that the current cadastral registration can provide in 3D property situations.

- In the Netherlands (and most other countries) no rules or standardisation exist for establishing rights and for setting up deeds in 3D situations, leading to diverse solutions. Every notary (or licensed surveyor in other countries) that is confronted to register rights in 3D situations has to decide upon which rights to use in specific situations and what information to include in deeds (ranging from detailed 3D surveys to a global description).

### **Cadastral registration of property units in building complexes**

Property units in buildings are mainly established by means of apartment rights, and sometimes with a right of superficies, as was seen in chapter 3. With the cadastral registration of these rights, it is possible to see which persons have a right on a parcel or an apartment unit. However, the cadastral registration cannot provide information on how properties are located in the complex itself. Also the property units in building complexes, which are established with means other than apartment rights cannot be found as distinct objects in the land and cadastral registration. Drawings can be added in deeds, which are archived in the land registration (which is obligatory only in the case of apartments rights). The deeds, and thus the drawings, will soon be available in scanned format, thus making these documents accessible through the cadastral network. However, spatial information in vector format in real world coordinates would provide the possibility to incorporate this information as part of the cadastral geographical data set.

### **Cadastral registration of infrastructure objects**

In case of infrastructure objects, the 2D parcel is strongly limiting the amount of information that can be obtained from the cadastral registration:

- The rights for 3D infrastructure objects are established by means of ownership rights, limited rights, and legal notifications; all established on intersecting parcels and not on the infrastructure objects themselves. These rights are not related to the infrastructure objects.
- There is no uniform way to establish the legal status of infrastructure objects and consequently the registration for infrastructure objects is not uniform.
- The infrastructure object is partitioned over the many parcels it intersects with. No information on the whole infrastructure object is available, not even an id, i.e. the existence of the object is not known in the cadastral registration. Since the spatial extent of the objects is not known the following queries cannot be performed ‘which parcels intersect with the 3D object?’ ‘what rights and restrictions are established on the parcels intersecting with the 3D object?’, ‘are there any 3D objects (tunnels, pipelines) intersecting with a specific parcel?’.
- When the parcel is subdivided (e.g. in case of a transfer of a part of the parcel), it is not always known in which part of the parcel an infrastructure object is actually located. Therefore, the cadastral database can become polluted since all child parcels will be encumbered with a restriction due to the (potential) presence of a construction. The registration does therefore not necessarily reflect the real situation.

## 5.2.2 Locating infrastructure objects in the current cadastre

There are basically three possibilities of locating infrastructure objects in the current cadastral registration. The case of the HSL railway tunnel (see section 3.2.2) can be used to illustrate these possibilities. We used the parcel boundaries of the intersecting parcels and 3D spatial information on the tunnel to create a fictive cadastral map (see section 12.1.5) with new parcel boundaries to limit the parts of the parcels that are affected by the tunnel (according to Dutch rules). Although the actual cadastral geographical data set of 2003 was used, the examples in this section are not intended to show the actual parcel boundaries: they are only meant to clarify the alternatives.

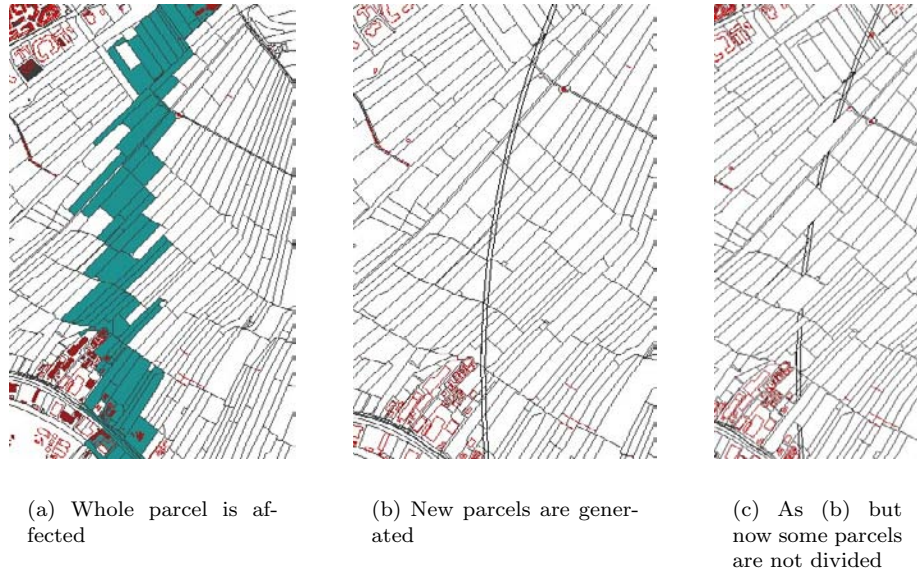

Figure 5.2: *Three possibilities to register infrastructure objects.*

The first map (figure 5.2 (a)) would be the result if all parcels intersecting with the tunnel were completely affected with a right to build the tunnel. The location of the 3D object is (vaguely) indicated when all parcels that are intersecting the tunnel are selected. This selection is done by finding all the parcels that are encumbered with a right of which the Ministry of Transport and Public Works is the subject. The relationships between the tunnel and (limited) rights and notifications that are established are not stored (the tunnel itself is not stored). The only information that the cadastral registration can provide is what rights and notifications are established on a parcel and who the subjects are of the rights and notifications. In the case of the HSL tunnel, this subject is the Ministry of Transport and Public Works. Since the Ministry owns many other objects as well, this does not give insight into the nature of the 3D object that the Ministry keeps on the intersecting parcels: the object could also be a viaduct or a road at surface level. In addition, the result could also be a mix of several different objects (belonging to the same owner).



When the tunnel partially intersects a parcel, normally the ownership or the right of superficies will just be obtained for only a part of the land (according to Dutch legislation, as explained in section 2.5.2). This will lead to the creation of new parcels. Figure 5.2 (b) illustrates this situation: the Ministry has obtained rights of ownership or superficies for the extent of the tunnel (with a needed safety zone on both sides). New parcels are generated. Still the relation between the tunnel and all the parcels is not maintained in the database. Because of the pattern of (new) parcels, the location and direction of the tunnel is clearly visible. But if other constructions are (partly) built on top of the tunnel and new parcels will be created according to the footprint of these buildings as in the Rijswijk case (section 3.2.1), this image will be disturbed. Also, the same parcel pattern might be the result in the case of physical objects above the surface (roads). The cadastral map is even more disturbed in figure 5.2 (c). It is more realistic to suppose that the Ministry is not the owner of only the land right above the tunnel, but also of complete parcels. For example when during the negotiations they agree to buy all the land from the original owner (and not only the small zone that is actually needed). In this case, there is no need to generate new parcels.

In case of cables and pipelines it is not always required to create new parcels to be able to establish the restriction on only a part of the parcel. In those cases AKR uses a ‘BZD’ or a ‘OLD’ code (see section 2.3.2). The exact location of the restriction can be defined in the deed, but is not maintained in the cadastral registration. Consequently, the location of the restriction is not clear from the cadastral registration. The alternative is to split parcels and to register a ‘OL’ code (BZ codes are not possible after 1992).

### 5.3 Basic needs for a 3D cadastre

The complexities described in the previous section, are not (all) new. However, they have become more obvious during the last decades. This is partly due to the fact that 3D situations have been occurring much more often than forty years ago (number of multi-purpose buildings has increased, number of cables and pipelines has grown, many tunnels have been built during the end of the last century). But also due to a considerable increase in the value of property during the last decades, users want to have the legal status of their property clearly ensured in the cadastre. This means that the cadastre should give sufficient insight into property and in the boundaries of property in all dimensions.

From the complexities and limitations summarised in the previous section, conclusions on the basic needs for a 3D cadastre can be drawn. The basic needs for a 3D cadastre can be summarised as:

- to have a complete registration of 3D rights (rights which entitle persons to volumes). The current cadastre already registers rights which entitle persons to volumes, however a 3D cadastre should explicitly register the 3D space to which these rights apply;
- to have good accessibility to the legal status of stratified property including (3D) spatial information as well as to Public Law restrictions.

It is disputable and dependent on the background of a cadastral registration if information that does not directly support the main tasks of a cadastre should be registered and maintained in the cadastral registration, e.g. the exact location of cables and pipelines. In addition, it will be more effective (e.g. with respect to data integrity and data consistency) if information on constructions and other objects of interest are maintained at their source and accessible within and from the 3D cadastre.

Based on these considerations, we can conclude that a 3D cadastre should incorporate the following functionalities:

- register 3D information on rights (what is the space to which the person with a real right is entitled?) and make this information available in a straightforward way;
- establish and manage a link with external databases containing objects of interest for the cadastre (infrastructure objects, soil pollution areas, forest protection zones, monuments) and incorporate the location (and other information) of these objects in the cadastral registration;
- use the information on these objects to support registration tasks, i.e. to detect and correct errors or in the process of registering and viewing the legal status of 3D situations. Are all intersecting parcel encumbered with a right for the infrastructure object?.

Linking different registrations and linking different databases can be established by the set-up of a well-working national Geo-Information Infrastructure (GII).

#### **Geo Information Infrastructure**

The term “Spatial Data Infrastructure” (SDI) or “Geo-Information Infrastructure” (GII) is often used to denote the collection of technologies, policies and institutional arrangements that facilitates the availability of and access to geo-information to the benefit of many users [132]. The word infrastructure is used to promote the concept of a reliable, supporting environment, analogous to a road or telecom-network, that, in this case, facilitates the access to geo-information using a minimum set of standard practices, protocols, and specifications. Like roads and networks, a GII facilitates the conveyance of virtually unlimited packages of geographic information [132]. A GII consists of the following four components [65]:

- geographic data;
- technology for storing, access, distribution and use of geo-information;
- standards for describing, exchanging and linking geo-information;
- policy and organisation.

A distributed set-up of registrations within a GII provides the possibility to link information maintained in different databases. In this way the geometry of infrastructure objects and other 3D objects of interest can remain and be maintained at their original source (in databases at organisations who are responsible for these objects), while this information can be used to improve cadastral registration in 3D situations.

## 5.4 Opportunities for a 3D cadastre

A 3D approach to cadastral registration offers improvements for the main tasks of a cadastre for a number of reasons:

- 3D registration provides information on the 3D extent of rights, limited rights and legal notifications and allows integration of 3D information in the current cadastral geographical data set. In the case of 3D registration, a 3D property unit can be queried in a 3D environment in the same way a parcel can be queried in the current registration (with some other attributes).
- A 3D cadastre will incorporate digital information on 3D situations. In the current registration analogue drawings clarifying the 3D information can be added to deeds. The availability of deeds in digital (scanned) form has already improved the accessibility of information. It is now possible to link digital documents to parcels in the cadastral geographical data set (e.g. the document appears after clicking on a parcel). However, a vector representation of the situation in the national reference system (not scanned) instead of a drawing will offer better registration possibilities, since it is easier to integrate the vector-information with the current cadastral geographical data set to get an overview of the whole 3D situation (and not just at the location of the specific parcel). Digital information will also offer better possibilities for quality checks. In addition, digital information facilitates the exchange and integration of information between and within cadastral offices, municipalities and provinces and it facilitates viewing of 3D (property) situations interactively.
- When enabling 3D registration, the parties involved have a tool to register 3D situations, which may motivate them to include spatial information in deeds and to establish the legal status of 3D situations in a uniform way. This makes it possible to have uniform, and consequently readily accessible, recordings of 3D property units (it should be noted that coordinates, also in 3D, should always be obtained from cadastral surveying).

A 3D cadastre can interact with other registrations, which offers other opportunities as well:

- If the exact 3D location of infrastructure constructions is available within the cadastral registration (maintained in databases by holders of these objects), the cadastre can use this source for certain cadastral tasks e.g. during clean-up of registration or to support other cadastral tasks.
- Holders of infrastructure constructions will benefit from a clear registration of the location of infrastructure objects, since they have more legal protection (rights are better maintained) and they do not pay compensation for parcels that do not intersect. In current practice errors occur such as a cable crosses a parcel but no limited right or notification has been established or a limited right or notification has been established while the parcel is not crossed by a cable. By knowing the exact locations, the parcels and thus the persons involved and who need to be compensated can be more accurately determined.
- Linking databases containing infrastructure objects with the cadastral registration can also be used for registering pipelines according to the Law on Telecommunication. According to a decision of the Dutch Supreme Court, telecom-networks are considered as immovable goods (this decision will in the future

apply to other cables and pipelines as well). Consequently the cadastre has to be able to register these networks apart from parcels and apartments (see section 2.4.1). This registration can be improved when a direct link is maintained with the database of the holder of the networks (and of other pipelines in the future).

## 5.5 3D applications outside the cadastral domain

To ensure legal security and to support town and regional management in general, 3D geo-information gets more attention in today's society where there is an increasing interest to place different types of land use on top of each other. Registrations and applications outside the cadastral domain are therefore also confronted with the fact that 3D information becomes more and more important. A 3D cadastre can benefit from other domains that develop towards 3D and vice versa, since knowledge and experiences can be shared and since 3D data can be interchanged.

Many examples of applications that have a growing interest in 3D information have been cited in [145, 146]. Traditionally, the military applications were the first to look for 3D solutions and provided the first elaborated systems for 3D visualisation and simulation [105]. Nowadays more and more civil applications need the third dimension:

- Urban planning is one of the most demanding areas pushing 3D developers to provide fast modelling approaches, extended visualisation and interaction tools, and elaborated spatial functionality [123, 190]. The influence of new buildings and infrastructure on the existing environment can be visualised best in 3D environments, which is important in discussions with citizens. In addition, 3D visualisations of planned infrastructure and underground constructions provides better insight into the vertical planning of regions [90].
- Landscape modelling seeks specific 3D tools for interactive design and simulation [12, 25].
- Road, railway and canal construction and maintenance benefits largely from visual 3D environments [15].
- Maintaining 3D information on real-world objects enables to deal with 3D characteristics of buildings, e.g. calculating the volume of buildings (for tax purposes) or dictating a maximum construction height and depth.
- 3D geo-information can serve as input for 3D spatial modelling such as modelling noise levels [93] and risk modelling for buildings when a tunnel is being drilled [124].
- Knowledge about 3D characteristics of natural processes can be used to impose limitations and obligations, e.g. in case of noise control, odour nuisance and safety measures.
- In telecommunications the decision on the locations of antennas requires 3D analysis to obtain information on the area which can be covered and on the costs of using a specific location.
- Geological applications (e.g. finding fractures or salt domes) require 3D analysis [230].

- In order to predict the consequences of bursting of dikes (flooding), a good terrain model is needed together with 3D software [231, 239].
- Cables, pipelines and tunnels can be better protected against damage when their 3D location can be visualised in the real world [182] (see figure 5.3). Based on knowledge of the location of constructions precisely defined restrictions can be imposed on the owners of the surface land from doing anything that could damage the underground construction.
- Location-based services (LBS) for shopping, tourism, rescue operations etc. is another area, where the use of 3D visualisation (and most probably 3D GIS) is rapidly increasing [29, 80].

A last example with increasing interest in incorporating 3D geo-information is the domain of local land use plans. At the moment there are no standards or rules to incorporate 3D information in local land use plans. Consequently every local land use plan that has to regulate different types of land use on top of each other reinvents the method how to deal with the 3D component of local land use planning. Local land use plans can also differ within one project since local land use plans are the responsibility of municipalities and infrastructure objects may cross municipality boundaries, e.g. as in the case of the HSL-tunnel.



Figure 5.3: *To avoid damage to cables, first digging by hand is necessary (Dutch Newspaper, July, 2000).*

An example of a local land use plan which had to deal with 3D information is the ‘Noord-Zuid lijn’ in Amsterdam.

### **3D local land use plan of the Noord-Zuid lijn Amsterdam**

In Amsterdam a metro-tunnel is being drilled from north to south (the ‘Noord-Zuidlijn’). A local land use plan was needed in which the use of a tunnel below other types of land use was guaranteed. The tunnel is planned partly below houses.

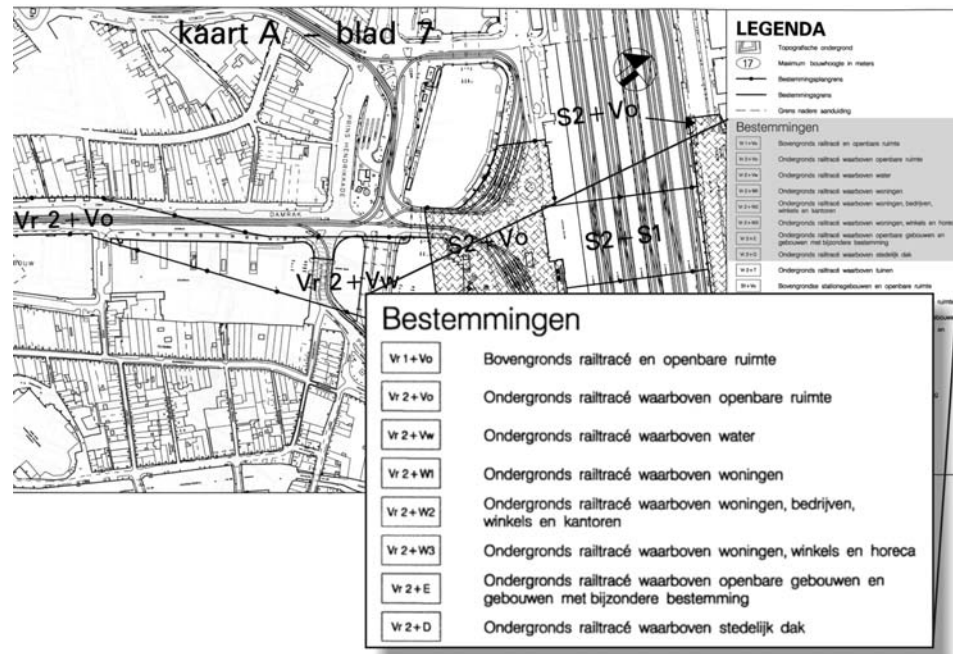

Figure 5.4: Local land use plan of metro tunnel (Noord-Zuid lijn) in Amsterdam. ‘Ondergronds railtracé waarboven’ means ‘Subsurface metro line on which’.

Figure 5.4 shows part of the map that was produced for this local land use plan. It is a 2D map. The areas on the 2D map are encoded (as ‘multi-layers’) and the 3D information (tunnel below houses) is added as a description in the legend and not as a 3D spatial description. Consequently, the local land use plan of the Noord-Zuidlijn does not include 3D spatial information (also not elsewhere in the local land use plan).

## 5.6 Conclusions

This chapter summarised from the previous chapters the complexities and limitations of current cadastral registration in 3D property situations.

From a juridical point of view it does not seem problematic to establish 3D property units. This can be realised either within juridical frameworks that still strongly hold to the unlimited concept of ownership that is linked to surface parcels (using right of superficies, apartment rights and strata titles) or within more flexible juridical frameworks that enable establishment of multilevel ownership (e.g. air-space parcels, volumetric parcels, construction properties) as was observed in a few other countries.

In the Netherlands, where 3D property units are established by means of limited rights on surface parcels, the registration of the legal status of 3D situations has until now been limited to an administrative registration. In the case of apartment units or

when more than one real right is established on one parcel, it is possible to see that it concerns a 3D situation. In those cases it is possible to query which rights and persons are involved. However, no 3D overview of the situation can be obtained.

Also abroad no solutions have been found to incorporate the 3D geometry of 3D property units in the cadastral registration. Current cadastral registrations all lack a fundamental approach for 3D cadastral registration by combining juridical, cadastral as well as technical aspects with respect to 3D situations.

From this chapter the essential elements for a 3D cadastre can be defined. A 3D cadastre should be able to:

- maintain the spatial extent of real rights, and provide information on the spatial extent of real rights;
- establish and manage a link with external databases that contain objects that are of interest for the cadastre (infrastructure objects, monuments, soil pollution zones etc.);
- use information on these objects in the work processes of cadastral registration.

Registration of 3D situations offers other opportunities as well. Once 3D information on situations is accessible (e.g. from the cadastral registration based on links with other registrations via the GII), this information can be used in other applications and vice versa. For example, exact information on the location of cables, pipelines and tunnels offers opportunities to use this information in the management (planning activities) of the subsurface.

The remainder of this thesis aims at meeting the needs of cadastral registration (with the main focus on cadastral registration in the Netherlands) by studying possibilities and constraints to establish a 3D registration both from a technical and a cadastral point of view. The proposed solutions for a 3D cadastre should fit to some extent in the current juridical framework of the Netherlands.





## Part II

# Framework for modelling 2D and 3D situations



## Chapter 6

# Theory of spatial data modelling

This chapter presents an overview of the basic concepts and terms in spatial data modelling. The aim is to familiarise the reader with concepts used in this thesis. First data models and in particular characteristics of spatial data models are described (section 6.1), followed by a description of the different phases in data modelling including their characteristics (section 6.2 to 6.4). UML (Unified Modelling Language) has become a standard to represent data models and is used to represent the data models in this thesis. Therefore a short introduction into UML is also included in this chapter (section 6.5). DBMSs are essential systems in spatial data modelling and in the new generation GIS architecture. Section 6.6 describes how the relationship between spatial data modelling in GISs on the one side and in DBMSs on the other side has evolved. Finally when looking at spatial data models, the standardisation initiatives on spatial data modelling are important, which are described in section 6.7. The chapter ends with concluding remarks.

### 6.1 Data models

The term ‘model’ is a frequently used term in many disciplines. Models in general are used to make an abstraction of reality with the aim to make reality understandable. Data models are intended to interpret the world in a way that is understandable to computers [223]. A data model is a generic blue print (structure); the data model can be populated with instances (data) to come to an abstraction of reality for a specific application. Data models consist of:

- classes;
- attributes;
- relationships;
- constraints;
- operations.

**Classes and objects**

In data models classes are abstractions of phenomena in the real world that can be identified, e.g. parcels, persons, buildings. Objects are instances of classes. An object instance has at least a unique id, which is in principal meaningless but which can be used in references. In data models, the term object does not refer to objects as they occur in the real world, but to the representation of the real-world objects, which may be very confusing. The representations can be maintained in a DBMS. For example a road can be referred to as an object, i.e. the representation of the road. The object, containing both spatial and non-spatial attributes, can be maintained in the DBMS (e.g. line, with attributes such as owner, type of asphalt etc). Objects are basic elements in object oriented modelling (see section 6.3.2).

**Attributes**

Objects have attributes in which the property of the objects is described, e.g. a land parcel can have 'area' or 'land use' as an attribute.

**Relationships**

In the data model, relationships exist between the objects, identifying how the objects are related. For example a land parcel has a relationship with person: a parcel is owned by a person. There are three kinds of relationships with respect to cardinality: one-to-one, many-to-one, many-to-many. The objects can be structured in a class hierarchy. Objects that are derived from other objects have either a 'is-part-of' or a 'is-a' relationship with the objects they are derived from. The first type of relationships is called 'aggregation' and the second type is called 'specialisation'.

**Constraints**

A constraint is a limitation on objects or on relationships in the data model, e.g. 'the age of the object person must be more than zero'. Consistency constraints can be used to prevent any logical contradiction within a model of reality [48]. This is not the same as correctness, which excludes any contradiction with reality itself. Consistency constraints are used to enforce the logical consistency of the data model. Consistency constraints can be organised into two groups [213]:

- Inherent constraints, which are incorporated in the definition of the data model. The model can disallow certain objects or limit certain relationships by its definition. For example if the data model does not define relationships between a parcel and a subject, this relationship cannot be maintained.
- Explicit constraints, which are not part of the data structure but which need to be explicitly defined, e.g. the constraint that an employee cannot earn more than his manager.

**Operations**

The operations describe all the actions that can be performed on objects. Here we focus on operations in DBMSs. Four generic DBMS operations on objects using the Data Manipulation Language are distinguished in the database literature [213]:

- retrieve: make a whole data set available to the user;
- insert: add new data to the database;
- delete: remove data from the database;
- update: change existing data.

Apart from these generic operations, in [213] three other supporting operations in DBMSs are distinguished:

- selection: retrieve operation under a particular condition;
- navigation: operations that permit a logical path on the basis of a selection to be followed;
- specialisation: complex operation that allows a new object to be created on the basis of existing ones.

Note that the term specialisation is also used to denote a special type of relationships in data modelling as was mentioned above.

### 6.1.1 Data models in GIS

In GIS, a data model is the structure used to identify and represent objects referenced by space relative to the earth surface [186]. Models of spatial information are usually grouped into two broad categories: field-based models (raster) and object-based models (vector).

In the field-based model, the world is modelled as a regular tessellation (raster), which is sampling based. For example height can be modelled in a field-based approach in which each point in space has exactly one value of height. Field-based models are often used to model continuous spatial trends such as elevation, temperature, and soil. In object-based models, the focus is to abstract spatial information into distinct, identifiable and relevant things or entities called objects. Individual objects are modelled together with their attributes. Object-based models are often used for man-made objects and are common in modelling transportation networks (roads), land parcels for property tax and legal ownership-related applications.

#### Objects in GIS

Traditionally geo-sciences focus only on real-world phenomena with a spatial extent. It is therefore relevant to distinguish between spatial (or spatial-temporal) objects and non-spatial objects. A spatial object is the representation of a real-world object having spatial (topology, size and shape, position and orientation) and thematic characteristics [6, 112, 118, 169]. A spatio-temporal object has three fundamental components: location (spatial), attributes (aspatial) and time (temporal) [233].

Till recently GIS models maintained only spatial objects, while non-spatial objects, such as subjects or rights in a cadastral context, were maintained in DBMSs or were integrated in GIS as semantic characteristics of spatial objects. However, integrated architectures are evolving in which both spatial and non-spatial objects are maintained in one integrated DBMS (see section 6.6).

#### Relationships in GIS

In spatial data models, spatial relationships exist. Spatial relationships describe the relationships between the geometric elements of spatial objects. In spatial modelling, spatial relationships serve two main purposes:

- to find the spatial relationships between two spatial objects (used in querying), e.g. find all parcels that are adjacent to a certain parcel;

- to enforce the consistency of a model by formulating consistency constraints using spatial relationships (used in modelling and editing), e.g. two parcels should not overlap.

Spatial relationships can be classified as topological or geometrical. Topological relationships describe the connectivity, containment and adjacency relationships among spatial objects. These relationships are invariant under topological transformation, such as translation, scaling and rotation [234]. Geometrical relationships are described in terms of distance and directions and depend on the absolute positions of objects relative to a given reference system [234].

### Constraints in GIS

In spatial data models, consistency constraints can be used to enforce spatial characteristics. For example topological constraints can enforce that lines only intersect at nodes and parcels shall not overlap. Semantic constraints can enforce spatial characteristics that are dependent on semantics, e.g. a building area should always be adjacent to a street [26]. Semantic constraints are application dependent.

### Operations in GIS

Operations on spatial objects can be performed on both the spatial characteristics and the thematic characteristics of the objects or on a combination of these characteristics. Here we focus on operations on spatial objects maintained in spatial models in DBMSs. DBMSs have a strictly defined functionality based on relational algebra and calculus [176] and were originally not designed to manage spatial objects. The traditionally available operations have to be ‘translated/extended’ into the spatial domain to be able to handle spatial objects. As was seen, four basic operations are distinguished in the database literature [213]: retrieve, insert, delete and update. A similar set of operations (but more elaborated) has to be available for spatial data. The operations related to introducing a new element, deleting and updating an existing one have to be extended with respect to the data structure used. In [186] four groups of operations related to DBMSs are distinguished that use the geometrical characteristics of spatial objects:

- Update operations: standard DBMS operations such as insert, delete, modify, etc.
- Select operations: e.g. ‘retrieve all parcels that overlap with this pipeline’. Three basic groups of selection operations with respect to spatial objects can be defined to be offered at DBMS level:
  - Metric operations: selection operations that require computations of geometrical properties, e.g. compute distance, volume, area, length and centre of gravity. Metric operations need coordinates of the spatial objects and the result is always quantitative. Metric operations are unary operations and should not be confused with metric relationships, which are binary operations.
  - Proximity operations: selection operations related to spatial location, e.g. objects in a certain area, volume or field of view.
  - Relationship operations: selection operations based on spatial relationships between objects.
- Spatial join: like the join operator in relational databases, the spatial join is one of the more important operators. When two tables are joined on a spa-

tial predicate (intersect, contains, is-enclosed-by, distance, northwest, adjacent, meets), the join is called a spatial join. This is equivalent to the map overlay in GIS. The operations combine two sets of spatial objects to form a new set. An example is ‘find all natural areas and forest areas that overlap’.

- Spatial aggregate: retrieve spatial objects based on spatial characteristics of other spatial objects; an example is ‘find the station closest to this building’.

The spatial join and the spatial aggregate are actually complex select operations.

In addition to these operations, the DBMS has to offer supporting operations such as navigation and specialisation. Navigation is an operation that is handled internally by the DBMS, e.g. follow pointers. Examples of spatial navigation related operations are route planning (which require multiple topology operations ‘meet’) and shortest path (which require multiple topology operations ‘meet’ and multiple metric operations ‘distance’). Specialisation operations are operations that create new objects on the basis of existing ones, which is a different meaning than the specialisation relationship in data modelling. A specialisation within the spatial domain would be when the user provokes the creation of a conglomerate called ‘university’ of several existing buildings. Buffer, convex hull, union of objects and all types of generalisations fall in the group of specialisation operations.

### 6.1.2 Design phases in modelling

A data model is a structure to capture an abstraction of reality for a specific application. In designing a data model three phases are distinguished in literature which have their own data model associated with them [213, 223]:

- a conceptual model (section 6.2);
- a logical model (section 6.3);
- a physical model (section 6.4).

## 6.2 Conceptual model

In the conceptual phase all classes that need to be included in the data model are identified, together with the characteristics and relationships of the classes. The aim of the conceptual model is to demarcate the part of the real world which is relevant for the specific application. The model has a high abstraction-level since it is the basis of the conception process. It consists of a schematic representation of phenomena and how they are related. The conceptual model not only provides a basis for schematising but is also a tool for discussion and, as such, a good conceptual model must be easily understandable. The model sharing may be done by using narrative language, but the transfer to the next stage is easier if a more formal language is used [99]. Till recently ER (Entity Relationship) [23] has been a popular tool for designing the conceptual data model. In the ER model, the world of interest is partitioned into entities (objects), which are characterised by attributes and interrelated relationships. Associated with the ER model is the ER diagram, which gives a graphic representation to the conceptual model. In the ER diagram entities are represented as

boxes, attributes as ovals connected to the boxes and relationships as diamond boxes. Recently UML (Unified Modelling Language) has become a standard for conceptual (and logical) model design. The UML class diagram is the counterpart of the ER diagram. UML will be discussed in more detail in section 6.5.

## 6.3 Logical model

In the phase of logical design the conceptual model is translated into a logical model. In this phase the conceptual schema is translated into the data model of a particular type of DBMS. Often the term logical model is associated with data structure, since in this phase the database structure is designed. Three types of database models are distinguished here (other examples are network models and hierarchical models): relational model, object oriented model and object relational model. These models will be described respectively in sections 6.3.1, 6.3.2 and 6.3.3.

### 6.3.1 Relational model

The relational model was introduced by Codd [27]. A relation is an organised assembly of data that meets certain conditions. A relational database is a collection of relations. A relation has a number of attributes or data items representing some property of an entity. Relational models have been widely adopted by the market and have been implemented in mainstream DBMSs.

A table in a relational database represents a relation, and each column of a table is called an attribute. An object type can be defined by one or more relationships. The relationships between tables are established by keys. A key is an attribute (or combination of attributes) that contains unique values for each row in the table. Certain constraints on the relational schema must be maintained to ensure the logical consistency of the data. Three kinds of constraints can be distinguished:

- Key constraints. The key constraint specifies that every relation must have a primary key. There may be several keys in a relation. The one that is used to identify the entities is the primary key.
- Entity integrity constraints. The entity integrity constraint states that no primary key can be null.
- Referential integrity constraints. Logically consistent relationships between the different relations are maintained through the enforcement of referential integrity constraints. This constraint can be implemented using a foreign key. A foreign key is a set of attributes in a relation that is duplicated in another relation. The referential integrity constraint stipulates that the value of the attributes of a foreign key either must appear as a value in the primary key of another table or must be null. Thus a relation refers to another relation if it contains foreign keys.

Data definition and data manipulation of relational models can be done with the Structured Query Language (SQL). A short introduction into SQL follows below.



## SQL

SQL is the most widely implemented database language for relational models. SQL has two components: the DDL (Data Definition Language) and the DML (Data Manipulation Language). The schema of the database (containing definitions for tables and constraints) is specified with the DDL. The DDL is used to create, delete and modify the definition of the tables in the database, while the actual queries are posed and rows are inserted, updated and deleted in the DML. The basic principles of SQL [214] are described below to provide understanding of the SQL statements used in this thesis. Oracle SQL is used here as example, although slight differences can be present between the SQL in different relational DBMSs. A table can be created using the DDL component of SQL:

```
CREATE TABLE subject (
  subject_id          number(12),
  name                varchar2(128),
  street              varchar2(24),
  place               varchar2(24),
  PRIMARY KEY subject_id)
```

The name of the created table is 'subject'. The table has four attributes, and the name of each column and its corresponding data type is specified. Tables no longer in use can be removed from the database using the 'drop table' command. After the table has been created, data can be inserted in the table ('populating the table'). This is done in the DML component of SQL. The following statement adds one row to the table 'subject':

```
INSERT INTO subject VALUES (999, 'Stoter', 'Jaffalaan 9', 'delft')
```

To add another row with the same subject.id will be rejected by the DBMS because of the primary key constraint specified in the 'create table' statement. The alternative to the insert command is 'bulk loading' which can be used to save time when inserting high volumes of data. Once the database schema has been defined and the tables are populated, queries can be expressed in SQL to extract the subsets of interest. The return values of a select query can also be the result of operations on the resulting subset. The basic operations are union, intersection and difference. All the rows of the table are scanned and the ones where the sought value is found are returned as results. The basic form of a select query (which is part of the DML) is:

```
SELECT column_names FROM relations WHERE row-constraint
```

Operations can be specified after both the SELECT and the WHERE key-word.

### 6.3.2 Object oriented model

Although objects always have been the basis in the conceptual phase of data modelling, the existing technologies forced the data model to be implemented in other structures such as the relational structure. However, relational modelling is table and record oriented and not object oriented, which has proved to have its limitations when modelling the real-world [74]:

- A restricted set of data types are available even for less complex data.

- The structure of relational databases (tables, rows, columns) does not accommodate complex data types easily.
- Complex data can be stored as BLOBs (Binary Large Objects), which can be retrieved from relational databases, but not searched, indexed, or manipulated.
- Relational tables offer an inadequate model of real-world objects, since you can only model objects as a set of relationships, e.g. how to deal with behaviour of objects.
- Relational tables offer poor support for integrity constraints.
- Operations are only available in a limited way.
- In relational DBMSs it is difficult to handle recursive queries.

The basic idea of object oriented modelling is to make a direct correspondence between real-world entities and their computer representation. In an object oriented data structure, classification is the main principle. Classification is the mapping of objects or instances to a common type. The combination of classes, objects and operations (methods), together with the inheritance principle, characterises the object oriented model, in contrast to the record oriented relational model [99].

### **Classes and objects**

Classes are collections of objects with the same behaviour. Instances are particular occurrences of objects for a given class. Within classes subclasses can be defined, for example the class trees can be divided into leaf trees and fir trees. The subclasses are specialisations of the superclass, as was mentioned before.

### **Attributes**

Objects have attributes associated with them with their data types (which can be user-defined data types). Attributes are the descriptive properties of the object. Instances of an object have all the attribute types of the class in common. Attribute values can be defined at either the class or the instance level.

### **Methods**

Classes are not only characterised by attributes but also by methods. ‘Method’ refers to an operation on objects: a procedure that can be applied to a class of objects. A method is a member function of the class.

### **Inheritance**

In classification hierarchies, an object in a subclass (specialisation) inherits all attributes of the corresponding higher-level superclass. For example if we have a superclass LineString we can define subclasses LinearRing and Line which both inherit the operation Length from LineString.

In object oriented modelling the spatial and non-spatial attributes of spatial objects are not very much different from each other. The attributes ‘area’ and ‘geometry’ of a land parcel are not treated differently as other alphanumerical attributes. According to [234] there are some problems with object oriented databases that cause performance to be a difficulty in object oriented databases:

- Provision of query optimisation is made difficult by the complexity of object types. Many operations are available compared with the few operations in relational DBMSs. It is therefore hard to estimate the cost of execution and to choose between different strategies to execute a query.

- Indexing is hard. The difficulty is that indexes rely on direct access to attribute values, while an object is only accessible via messages through its protocol and identified by the object-id.
- Transaction in object oriented databases may be of a much higher level of complexity than simple transactions within a relational DBMS. Due to the hierarchical nature of much object data, transactions may cascade downwards and affect many other objects.

According to [74] the problems of the object oriented approach are that there is no standard data model, object orientation has no clear theoretical basis and, most importantly, there is no standard query language, such as SQL in relational databases. Because of these problems, object oriented modelling has been less adopted in mainstream DBMSs than relational modelling.

### 6.3.3 Object relational model

The object relational model [195] introduces the advantages of object oriented models in relational models. In relational databases the set of data types is fixed. In object relational modelling this limitation is overcome because of the built in support for user-defined data types: Abstract Data Types (ADTs). Like classes in object oriented technology, a user-defined type consists of (internal) attributes and member functions to access the values of the attributes. Member functions are callable within SQL and can modify the values of the attributes in the data type. A user-defined type can appear as a column attribute type in a relational schema. The term abstract is used because the end user does not need to know the implementation details of the associated functions. The structure is hidden from the user, who can access it only through the operations defined on it. All that the end users need to know is the interface, i.e. the available functions and the data types of the input parameters and output results [186]. The ADTs appear at the same level as base data types, such as float or string.

#### Spatial data and Abstract Data Types

Spatial database applications must handle complex data types such as points, lines and polygons in 2D and 3D and also 3D primitives such as polyhedrons. Traditional relational DBMSs only support a set of alphanumeric data types (date, string, number). In [47] it was stated that the principal demand of spatial SQL is to provide a higher abstraction of spatial data by incorporating concepts in relational databases closer to our perception of space. This can be accomplished by incorporating the object oriented concept of user-defined ADTs. When a user-defined type 'point' is created, one can define a column name 'location', of type 'point'. The operations that can be performed on the data type are stated in the type definition. For the point type for example a function 'distance' can be defined, which computes the distances between two points. Another example is a land parcel stored in the database. A useful ADT may be a combination of the type polygon and some associated function (method), say 'is\_adjacent'. The adjacent function may be applied to land parcels to determine if they share a common boundary.

The OpenGIS Consortium (see section 6.7.1) defined specifications for incorporating

2D spatial ADTs in SQL. These ADTs include topological and geometrical operations. How mainstream DBMSs implemented these specifications is described in detail in chapter 7.

## 6.4 Physical model

In the phase of the physical design, the logical model is translated into hardware and software architecture. The physical model is hidden from the user. The design of the physical model is critical to ensure reasonable performance for various queries. Therefore, the physical design has to enable the operations for manipulating the logical model in an efficient way. At the physical level the following tasks are handled by the DBMS [178]:

- **Storage.** The DBMS manages an efficient organisation of the data on a persistent secondary storage unit (mostly one or many disks). The representation at this level might be completely different from that shown to the user according to the logical data model. A table might be stored in several files, possibly distributed over many disks. Data sets are often too large to fit in the primary memory of the computer and accessing secondary memory is much slower than accessing primary memory caused by moving the head of the disk reader. On the other hand transporting data between primary and secondary memory may also cause a performance bottleneck. The goal of good physical database design is therefore to keep the amount of data transfer between primary and secondary memory to an absolute minimum.
- **Access paths and (primary) indexes.** In response to a query the spatial access method should only search through a relevant subset of objects to retrieve the query answer set. This can be achieved by primary and secondary indexes. Primary indexes are built with the table itself, while secondary indexes are additional structures. A DBMS provides data access methods or access paths that accelerate data retrieval. A typical data structure that accelerates data retrieval is the B-tree [28].
- **Query processing.** Processing (evaluating) a query usually involves several operations. To efficiently evaluate the query, these operations must be properly combined. An important issue in query processing is the design of efficient join algorithms.
- **Query optimisation.** Because most query languages are purely declarative, it is the responsibility of the system to find an acceptably efficient way to evaluate a query.
- **Concurrency and recovery.** The DBMS manages concurrent access to data and resources from several users and should guarantee the security and consistency of the database, as well as the recovery of the database to a consistent state after a system failure.

Another aspect that can be added to this list is [186]:

- **Clustering:** Goal of clustering is to reduce seek and latency time in answering queries that result a range of data. For spatial data this implies that objects that

are close to each other in the real world and are commonly requested jointly by queries, should be stored physically together in secondary memory. The design of spatial clustering techniques is more difficult compared with traditional clustering, because a storage disk is a one-dimensional device. What is needed is a mapping from a higher dimensional space to a one-dimensional space which is distance preserving. Several mappings to accomplish this are Z-order, Gray code and Hilbert curve [52].

## 6.5 UML

The Unified Modelling Language (UML) [215] has become a standard language for object oriented software design at the conceptual level but also for many other applications. The language can be used to model the structural schema of a data model at conceptual level. There are many types of UML diagrams: use-case diagram, class diagram, object diagram, sequence diagram, collaboration diagram, statechart diagram, activity diagram, component diagram and deployment diagram. Apart from the diagrams the UML-standard offers a language to formally describe limitations and constraints in the diagrams: the Object Constraint Language (OCL). UML has two diagrams to describe the static structure of a system: class diagram and object diagram. Both diagrams show the elements of the system and the structural relationships. The class diagram contains the classes in the system with their attributes, operations, relationships (associations) and constraints. The class diagram is a model: it describes the structure and the limitations of the objects. The object diagram is a representation on a certain timestamp of the objects that have been created according to the structure of the class diagram. In most cases only the class diagram is used. In this thesis the class diagram of UML is used to describe the data models. UML notation for class diagrams is briefly described in this section (see also [228]).

### Class

Class is the encapsulation of all objects which share common properties in the context of the application. The UML notation of a class is a rectangle with three parts. In the top of the rectangle the name of the class is stated, in the second part the attributes and in the third part the operations.

Parcel
+Object_id:number
-First_line_id:number
+Return_polygon(object_id):geometry

### Object

An object is denoted in UML with a rectangle containing underlined text, starting with a colon, followed by the name of a class (e.g. : Parcel).

### Attributes

An attribute is information, maintained by an object (instance of a class). Every attribute has exactly one value for every instance of the class. These values represent the state of an object. Attributes are stated in the middle part of the representation of a class. The type of the attribute is reflected after the colon after the name of the

attribute. A '+' for the attribute indicates that the attribute is known outside the object (public attribute), a '-' indicates that the attribute is only known within the object (private attribute).

### Operations

The collection of operations of an object represents the behaviour of an object. Since all instances of a class have the same operations, the operations are described within the class. An operation can have arguments and a return-value. Operations are stated in the bottom part of the representation of a class. Parameters are given with round brackets after the operation name. The type of a return-value is given behind a colon after the parameters. The '+' or '-' can be added to indicate whether the operation is public or private.

### Association

An association is a structural relationship between two classes. Structural means that an instance from one class is related to an instance from the other class during its existence. The relationship can change over time. Between two classes more than one association can be defined. For example a person can work for a company, and a person can be a customer of a company. In UML an association is drawn with a line. The name of an association is typed along the line. The names of the relationship are drawn from left to right and from top to bottom. If this is different, an arrow indicates the direction of the relationship. The following types of associations can be distinguished:

- generalisation/specialisation;
- aggregation;
- composition.

### Generalisation/specialisation

Generalisation is the grouping of classes into new classes. A new class can be specified if there are more than one class with identical characteristics (operations or attributes). The original classes inherit these identical characteristics of the new created class. The new class is called superclass or generalisation, the classes with the identical characteristics are called subclasses or specialisations. In UML a generalisation/specialisation is drawn with a large, open arrow. The arrow points to the superclass (see figure 6.1 (a)). A superclass can represent an abstract class. An abstract class is a class of which no instances can exist. In UML this is denoted by giving the name of the class in italics, optionally followed by {abstract}, or by denoting it as a stereotype, using <<name\_stereotype>>. A stereotype can be used to specify that the class or object belongs to a more general group of classes or objects which give them specific characteristics, e.g. interface, enumeration, application, implementation, abstract etc.

### Aggregation

Aggregation is a special kind of association to show that one or more classes are part of another class. The parts can exist independently from the complex class. An example of an aggregation is a bicycle having wheels and a frame. The wheels and frame can exist individually and can be taken from the bicycle to be used for another bicycle. In UML an aggregation is denoted with a white diamond on the side of the complex (figure 6.1 (b)).

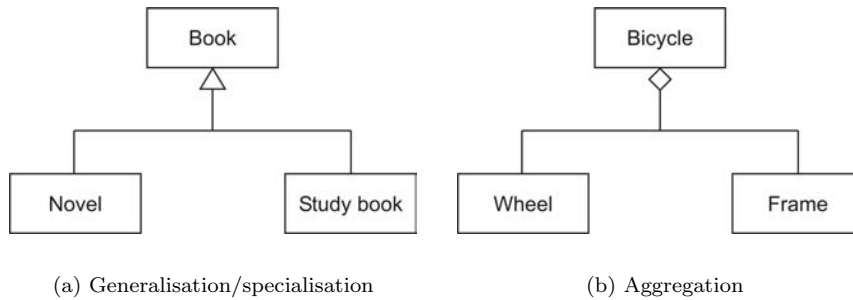

Figure 6.1: *Examples of UML notations.*

### Composition

In a composition relationship, also a special kind of association, a part can only belong to one complex and there is a restriction that a part ceases to exist when the complex ceases to exist: a part cannot exist independently from the complex. This is called lifetime dependency. An example is a polygon existing of linear rings, when the polygon is removed, the linear rings defining the polygon also cease to exist. A composition is denoted with a black filled diamond on the side of a complex.

### Multiplicity

The multiplicity is the number of instances of the associated class with which one instance of the class can have a relationship. In UML the multiplicity is drawn with an asterisk or a number. When nothing is defined, the multiplicity is one. The possible notations for multiplicity are:

- 5: exactly 5;
- \*: zero or more;
- 1..\*: one or more;
- 2..5: two till five;
- 2,5: two or five.

The multiplicity can be drawn on both sides of the association. The multiplicity in figure 6.2 (a) is read as 'a car transports two till six passengers and a passenger is transported by zero or one car'.

### Association class

An association class is a class related to an association. This means that the class is identified with the association, which contains additional details (attributes, operations). As soon as there is a relationship between two instances, an instance of the association class exists. An example of an association class is a marriage, which is an association class between a man and a woman, and in some countries also between a man and a man or a woman and a woman (or between one woman and one or more men or vice versa) (see figure 6.2 (b)). An association class is used when the association has attributes, when the association has operations or when the association itself has associations with other classes than the two on which this association is based.

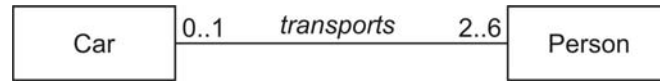

(a) Multiplicity

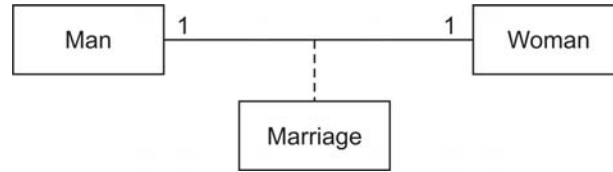

(b) Association class

Figure 6.2: *Examples of UML notations.*

An association class is like a normal class and therefore it has the same characteristics as normal classes within UML. In UML notation an association class is drawn with the class symbol which is linked with a dashed line to the association it belongs to.

### Constraints

A constraint is a limitation on one or more elements in the class diagram. In UML constraints can be defined using the OCL (Object Constraint Language). An OCL-constraint is denoted with the notation {OCL-constraint} in a notebox linked to an object or class, e.g. {area of parcel > 0}. There are also two predefined constraints in UML:

- The ordered collection of objects with multiplicity greater than one is denoted with {ordered}, e.g. the ordered collection of linear rings in a polygon.
- The symbol {XOR} with a dashed line to two or more associations indicates that only one of the associations can be instanced, e.g. a cadastral object can be an apartment unit or a parcel, but not both.

An example of an UML class diagram is shown in figure 6.4, section 6.7.1.

## 6.6 Spatial data modelling and DBMS

Spatial data is mostly part of a complete work and information process. Therefore in many organisations there is a growing need for a central DBMS (at least at the conceptual level) in which spatial data and alphanumeric data are maintained in one integrated environment. Consequently DBMSs are an essential part of the new generation GIS architecture.

An extended description on how GISs have evolved with respect to DBMSs can be found in [221]. GISs used to be organised in a dual architecture consisting of 1) data



management for administrative data in a (relational) DBMS and 2) data management for spatial data in a GIS. This was caused by the different nature of alphanumeric and spatial data and the inability of early DBMSs to handle spatial attributes. In the dual architecture (figure 6.3, left) the two parts are connected to each other via links (unique id's). The spatial attributes are not stored in the DBMS and therefore they are unable to use the traditional database services (query, index). In the dual architecture the consistency of the data is hard to manage. For example if a parcel is deleted in the spatial part, persons can no longer have a relationship with this parcel, which is maintained in the non-spatial part.

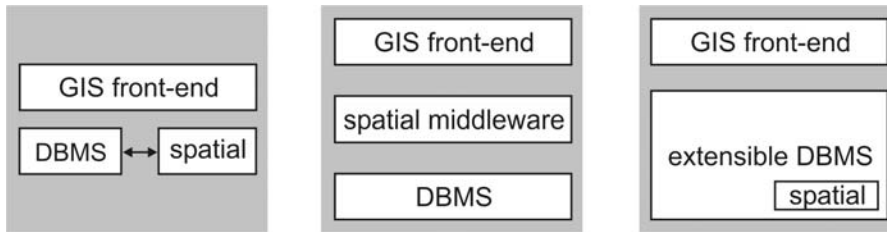

Figure 6.3: *Evolving architectures of GIS. Left: dual architecture; middle: layered architecture, right: integrated architecture, taken from [221].*

The solution to the problems of dual architecture was a layered architecture in which all data is maintained in a single (relational) DBMS. Since spatial data types were at that time not supported at DBMS level, knowledge about spatial data types was maintained in middleware (figure 6.3, middle). Spatial information was maintained in the DBMS by means of BLOBs (Binary Large Objects). SQL cannot process data stored as BLOBs and therefore the data depends on the host application code, which handles the data in BLOB format. This solution requires data transport from the DBMS to middleware and consequently queries cannot be implemented optimally.

In recent times DBMSs have evolved towards an integrated architecture in which all data is maintained in one object relational DBMS (figure 6.3, right). Presently, most mainstream DBMSs support spatial data types and spatial functions by means of ADTs. This architecture ensures an integrated and consistent set of data. Chapter 7 describes the state-of-the-art of geo-DBMSs in this new integrated GIS architecture.

## 6.7 Standardisation initiatives

Since the same geo-information is used by more and more people and applications, interoperability of geo-information and geo-processes (together named geo-services) has become a major issue in geo-sciences. With respect to interoperability, three standardisation initiatives should be discussed and taken into account in this thesis, i.e. OpenGIS, ISO TC/211 and CEN/TC 287.

### 6.7.1 OpenGIS Consortium

The main mission of the OpenGIS consortium (OGC), founded in 1994, is to enable interoperability of geo-services. Interoperability is the ability of digital systems to 1) freely exchange all kinds of spatial information and 2) cooperatively run software capable of manipulating such information over networks [157]. The OGC Specification and Interoperability Program provide an industry consensus process to plan, develop, review and officially adopt OpenGIS Specifications for interfaces, encodings and schemas that enable interoperable geo-services, data, and applications [157]. At the moment more than 250 public and private organisations participate in OGC. Among the members are TU Delft, the Netherlands' Kadaster and ITC. An important concept in the OGC model is a spatial (or geographical) feature, which is an abstraction of a real world phenomenon associated with a location relative to the earth [152] and a geometry. The basic spatial class of the geometries is 'GM\_Object' (figure 6.4).

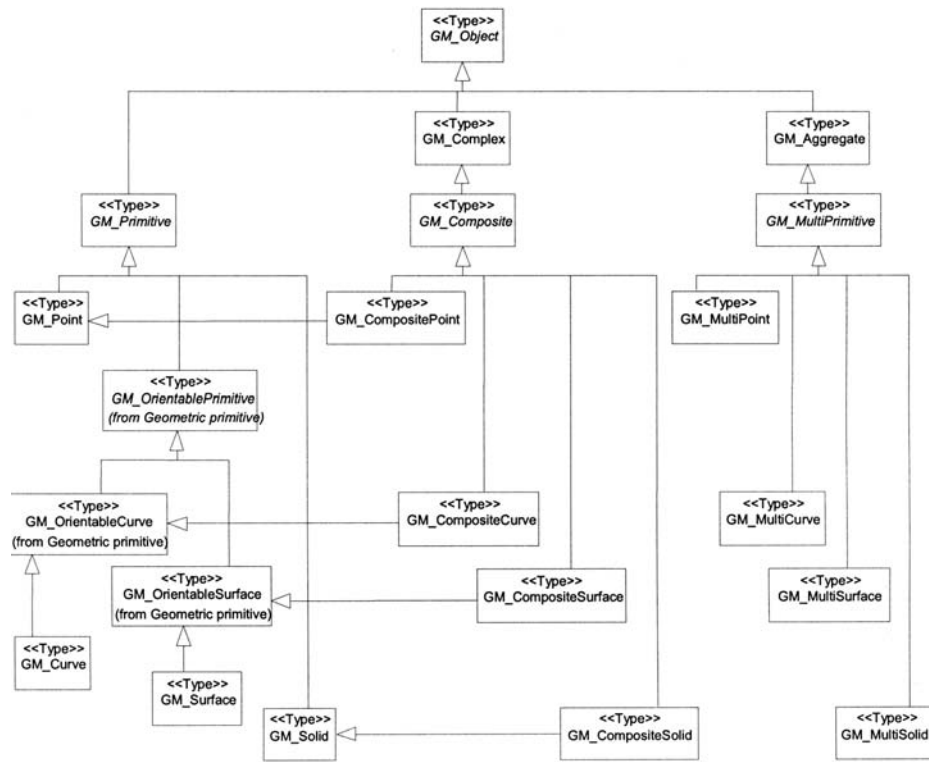

Figure 6.4: UML class diagram of geometry basic classes with specialisation relations, taken from [152].

OGC produces Abstract Specifications and Implementation Specifications [150]. The aim of the Abstract Specifications is to create and document a conceptual model sufficient to create the Implementation Specifications. The Implementation Specifications translate the Abstract Specifications into common distributed computing

environments (e.g. Corba, DCOM, Java, HTTP). UML is (mainly) used as basic language for the formalism of models defined in the Abstract and Implementation Specifications. Examples of Implementation Specifications are [159]:

- OpenGIS Location Services (OpenLS): consist of the composite set of basic services comprising the OpenLS Platform for location based services (mobile GIS).
- Catalog Interface: defines a common interface that enables diverse but conformant applications to perform browse and query operations against distributed and potentially heterogeneous catalog servers.
- Coordinate Transformation Services: provide interfaces for general positioning, coordinate systems, and coordinate transformations.
- Grid Coverages: designed to promote interoperability between software implementations by data vendors and software vendors providing grid analysis and processing capabilities.
- Simple Features - CORBA: provide application programming interfaces (APIs) for publishing, storage, access, and simple operations on Simple Features (point, line, polygon, multi-point) using CORBA.
- Simple Features - SQL: provide application programming interfaces (APIs) for publishing, storage, access, and simple operations on Simple Features (point, line, polygon, multi-point) using SQL.
- Simple Features - OLE/COM : provide application programming interfaces (APIs) for publishing, storage, access, and simple operations on Simple Features (point, line, polygon, multi-point) using OLE/COM.
- Geography Markup Language (GML 3.0): the Geography Markup Language (GML) is an XML (eXtensible Markup Language, see section 8.4) encoding for the transport and storage of geographic information, including both the spatial and non-spatial properties of geographic features.

### Geography Markup Language

An example of GML code to describe a polygon in 3D space, is:

```
<gml:PolygonPatch>
  <gml:exterior>
    <gml:LinearRing>
      <gml:coordinates>
        105111.588,448909.588,9 105132.743,448884.341,9 105137.45,448888.285,12
        105116.295,448913.532,12 105111.588,448909.588,9
      </gml:coordinates>
    </gml:LinearRing>
  </gml:exterior>
</gml:PolygonPatch>
```

The conceptual model underlying the representation of geometry and topology in GML [155] is that of Topic 1 of the OGC Abstract Specification [152] (which adopted the ISO 19107 standard, see next section and chapter 7). The ISO model describes the correspondence of topological and geometrical relationships up to three dimensions. GML 3.0 [155] includes the ability to handle complex properties, to describe coordinates with x,y and z (already possible in version 1 and 2) and to define 3D

objects. A topological volume in GML is described using the TopoSolid type. A TopoSolid type is defined by faces, faces are defined by edges and edges are defined by nodes. The user is free to choose where to explicitly store the geometry: at face, edge or node level. However, the topology has to be defined fully to node level. The user is also free to choose whether to define co-boundary relationships as well, i.e. the face-solid relationships, the edge-face relationships and the node-edge relationships.

### **OGC Web Services**

OGC specifications also define several Web Service Implementations for disseminating geo-information across the Internet: Web Map Services, Web Feature Services, Web Coverage Services and Web Terrain Services. A service is a collection of operations, accessible to a user through an interface [156]. OGC compliant applications operating on user terminals (e.g. desktop, notebook, handset, etc.), can then “plug into” a server supporting the services to join the operational environment. Web Services are based on the general request-response rules used by Hypertext Transfer Protocol (HTTP). Support of GET and POST methods are available within this protocol. An example of a HTTP request is:

```
http://www2.dmsolutions.ca/cgi-bin/  
mswms_world?SERVICE=WMS&Version=1.1.1&Request=GetMap&LAYERS=WorldGen_Outline
```

The OGC specifications for Web Services describe how to define a request string to be appended to the URL sent to the specific Web Service. They also define what requests are possible and what the output format of the responses should be.

#### *Web Map Services*

The Web Map Service Specification (WMS) [153] was the first OGC Implementation Specification to standardise the way in which a client requests maps. Clients communicate with a WMS by sending a URL request (using the HTTP protocol) to a WMS instance via general Web Server software like Microsoft Internet Information Server or Apache. The URL contains the name of the layer and other parameters such as the size of the returned map as well as the spatial reference system to be used when drawing the map. The WMS defines three operations:

- **GetCapabilities:** the response to a GetCapabilities request is general information about the service itself and specific information about the available maps.
- **GetMap:** returns a map image with a defined spatial extent and spatial reference system.
- **GetFeatureInfo (optional):** returns information about features shown on the map based on the x,y position indicated by a click action of a user.

#### *Web Feature Services*

The next step was the Web Feature Service Specification (WFS) [154] that provides further extension of Web functionality, i.e. insert, update, delete and query of geographic features. A WFS delivers GML (vector) representations of features in response to queries from HTTP clients instead of image representations in case of a WMS. Clients access features through WFS by submitting a request for just those features that are needed for an application. A WFS can either be a basic WFS (read-only) or a transaction WFS. A basic WFS implements three operations:

- **GetCapabilities**: similar as in WMS.
- **DescribeFeatureType**: returns a schema of the data structure of the data set maintained at the data host on which the WFS has been implemented.
- **GetFeature**: returns a set of features in GML according to the query of the user based on spatial and non-spatial attributes of features.

With a transaction WFS it is, apart from querying features, also possible to insert, delete and update data. Therefore a transaction WFS implements, in addition to supporting all the operations of a basic WFS, the Transaction operation (and optionally the LockFeature operation).

#### *Web Coverage Services*

The Web Coverage Service Specification (WCS) [158] defines Web based access to raster data. The raster data can be delivered in image format and can be further processed, e.g. rendered by visualisation software at client-side or used as input into scientific models. Operations in WCS are very similar to WMS operations which work only on vector data.

#### *Web Terrain Services*

The Web Terrain Services Specification (WTS) [149] (not yet fully adopted as OGC specification) defines how to create views out of 3D data, like city models and digital elevation models. The view (3D scene) is defined as a 2D projection of 3D features into a viewing plane. The view is created based on input parameters, such as point of interest and horizontal angle between the north direction and the horizontal projection. The Service returns a rendered (2D) image of the 3D view.

We illustrate the working of OGC Web Services by showing the system architecture for a WFS and WMS (figure 6.5). A client sends a URL, defining a request, to a Web Server. The Web server sends the HTTP request to an OGC Web Service (WMS or WFS). The OGC Web Service translates the request and sends it to a data host. The data host sends the resulting dataset to the OGC Web Service, whereupon the OGC Web Service translates the resulting data set into a format understandable to the client, as an image in case of a WMS or GML format in case of a WFS. The OGC Web Service sends the image or GML file back to the client. To be able to view the data at the client, the client needs to be able to ‘understand’ the image respectively GML.

### 6.7.2 ISO TC/211

The ISO Technical Committee 211 (TC/211): Geographic Information/Geomatics also defines standards related to GIS. TC/211 prepares geographic information standards in cooperation with other ISO technical committees working on related standards such as IT standards. The project no. 19107, Geographical Information: Spatial Schema defines a conceptual model of geometry and topology related to geographic features.

TC/211 is divided into several working groups. In total nine working groups have been started, while four of them have been disbanded since they achieved the goals of the specific working group [86]. Working groups that were disbanded are:

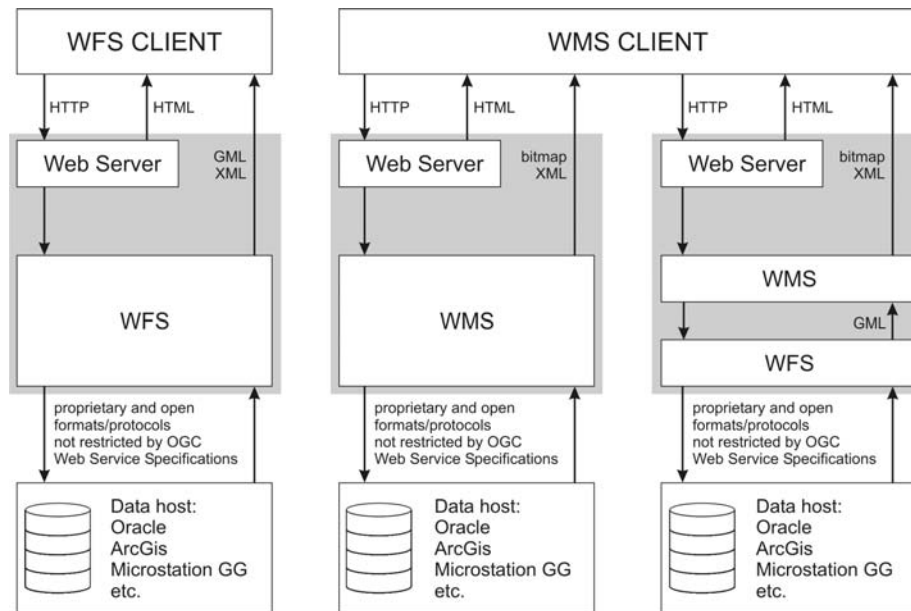

Figure 6.5: *System architecture for disseminating geo-information using Web Map and Web Feature Services.*

- Working group 1: Framework and reference model
- Working group 2: Geospatial data models and operators
- Working group 3: Geospatial data administration
- Working group 5: Profiles and functional standards

Working groups that are still alive are:

- Working group 4: Geospatial services
- Working group 6: Imagery
- Working group 7: Information communities
- Working group 8: Location Based Services
- Working group 9: Information Management

Since 1997 ISO and OGC have worked together based on the large overlap of their area of interest. Today, OpenGIS Consortium is working, via formal liaisons, with ISO TC/211 to harmonise abstract and implementation specifications. OGC members have access to key ISO documents and contribute (indirectly) to their evolution and in turn some of the future OGC specifications (geometry, metadata) will essentially be ISO specifications repackaged under agreement. In the future, the same specifications will be published by both ISO and OGC (“i.e. double branding”).

### 6.7.3 CEN/TC 287

In 1992 a special Technical Commission (TC) was erected as part of the European Commission of Normalisation (CEN, Comité de Normalisation) [21]: CEN/TC 287 Geographical Information. This TC ended her work in 1999 with the publication of a list of ENVs (European Norme Vorläufig: tentative norms) in the area of geographical information aiming at the European market and society [1]. CEN/TC 287 was in process from 1992 to 1999. It was expected that ISO/TC 211 would take over the European working-programme of standardisation in the area of geographical information and that it was not necessary to have two TC's. This was indeed the case when ISO TC/211 was erected. However now the European market has to decide how to include the ISO norms in current practise. Therefore in May 2003, CEN/TC 287 was brought back to live under the secretary of the NEN (*Nederlands Normalisatie Instituut*). The main goal of this new committee is to harmonise the ENVs developed in the nineties with the ISO TC/211 norms, developed since 1995 [1].

Also at national level initiatives on normalisation are developing. In the Netherlands a Geo-information Terrain Model was designed in 1995 [131]: NEN3610. This model was designed by the RAVI (*Stichting Ravi netwerk voor geo-informatie*) in collaboration with organisations and institutions. The aim of the NEN3610 model is to be able to easily exchange geographical information between different groups. The model describes objects at a global level. On a more detailed level NEN1878 and NPR3611 (practical regulations) have been developed. The project 'Framework for Geo-information exchange' (*Framework voor Geo-informatie uitwisseling*) will improve NEN3610, and replace NEN1878 and NPR3611 in order to better harmonise with international developments on open standards and in order to overcome the limitations of the current models [1].

## 6.8 Conclusions

In this chapter the main topics of spatial data modelling were described. Applying these topics to the 3D cadastre research, a few concluding remarks can be made.

### Object-based or field-based

For the 3D cadastre model an object-based (vector) approach instead of a field-based approach (raster) has been chosen for the spatial modelling part. The character of cadastral data (parcels, property) favours an object-based approach (no continuous character, identifiable objects, man-made objects). However, the terrain elevation aspects could be treated with a field-based model.

### Core objects of a 3D cadastre

In 2D, the core object for a cadastre is the real estate object (parcel) that is registered in the cadastral system. A parcel is not always easy to identify in the field. The parcel has a relationship with persons via rights and/or restrictions as was seen in section 2.2.3. For the 3D cadastre, the objects to be considered are:

- representation of physical objects as they occur in the real world (tunnel, cable, pipeline);

- ‘property objects’, which are representations of 3D property units. Property objects are not always directly identifiable in the field, for example if a right of superficies has been established while the actual construction has not been built yet or when a right of superficies has been established for a tunnel which also includes a safety zone.

### **Phases of data modelling**

In chapter 10 the conceptual model for a 3D cadastre will be described that has been designed during this research.

The next step is the translation of the conceptual model into the logical model (i.e. database structure of DBMS). As was seen in section 6.3.2 relational models have basic drawbacks when modelling the real world. Especially when modelling topological and geometrical characteristics of spatial objects. An object oriented approach overcomes these drawbacks. However, true object oriented DBMSs have only been implemented and used limitedly and object oriented technology still needs to be further developed and optimised, as was seen in this chapter. Object relational models, which are the compromise between the relational and the object oriented paradigm, are likely to be the leading DBMS technology for the next decades. In addition object relational models offer sufficient functionality for the 3D cadastre domain. Therefore an object relational DBMS was selected for the 3D cadastre prototypes. Since this research does not aim at a complete operational application (although parts of a 3D cadastre have been developed in different prototypes) the logical model for a 3D cadastre will not be completely designed during this thesis. Only the main part of the data model will be translated into a logical model and implemented in prototypes. In chapter 11 principles of the DBMS model for a 3D cadastre will be considered, as well as what issues should be taken into account when designing the logical model for a 3D cadastre.

The physical model for a 3D cadastre is beyond the scope of this thesis.



# Chapter 7

## Geo-DBMSs

In section 6.6 it was concluded that DBMSs play a central role in the new generation GIS architecture. Within this architecture spatial and non-spatial information on objects is maintained in one integrated DBMS environment, called a geo-DBMS. This chapter describes how spatial information on objects can be structured in DBMSs and how this information can be used, e.g. in spatial analyses.

The OpenGIS Consortium adopted the ISO 19107 international standard [87] as Topic 1 of the Abstract Specifications: Feature Geometry [152]. These Abstract Specifications provide conceptual schemas for describing the spatial characteristics of spatial objects (geographic or spatial features, in OGC terms) with vector geometry and topology up to three dimensions embedded in 3D space. The Abstract Specifications also describe a set of spatial operations consistent with these schemas. According to the specifications, the spatial object is represented by two structures: 1) structure of geometrical primitives (i.e. simple feature) and 2) topological structure (i.e. complex feature). While the geometrical structure provides direct access to the coordinates of individual objects, the topological structure encapsulates information about their spatial relationships.

Geometrical primitives are a combination of geometry (coordinates) and a coordinate reference system. Topological primitives make use of id references to low dimensional primitives, e.g. a polygon refers to its edges and nodes. The coordinates are stored only with the low-dimensional primitives. In principle, topological primitives are introduced to accelerate the computational geometry algorithms replacing them with combinatorial ones. Topological primitives only have meaning within a topological model. The OpenGIS Abstract Specifications have been transformed into Implementation Specifications, of which the most relevant for this research is: the OpenGIS Simple Features Specification for SQL [148], which supports spatial objects up to two dimensions (in 2D and 3D space) in object relational DBMS environments. Mainstream DBMSs have adopted these Implementation Specifications.

This chapter describes how mainstream DBMSs can maintain spatial objects, using both a structure of geometrical primitives (section 7.1) and a topological structure (section 7.2). Section 7.3 describes spatial analyses that can be performed in DBMSs

distinguishing between analyses that can be performed on geometrical primitives and analyses that can be performed on topological structure.

As will be seen in this chapter current support for 3D in DBMS is limited. Therefore, as part of this research a 3D primitive was implemented in a mainstream DBMS. The implementation will be described in section 7.4. When talking about 3D, the 2.5D representation of the terrain in a TIN (Triangular Irregular Network) structure should also be a topic of attention. The issue of TIN structures representing heights will be elaborated in chapter 9. This chapter ends with concluding remarks (section 7.5) including a discussion on which spatial analyses should be DBMS built-in functionality and which spatial analyses should be reserved for front-end applications.

## 7.1 Geometrical primitives in DBMSs

Mainstream DBMSs (Oracle, [160], IBM DB2 [82], Informix [83] and Ingres [84]) and also popular non-commercial DBMSs such as PostgreSQL [172] and MySQL [122] have implemented spatial data types and spatial operators (also called ‘spatial functions’) more or less similar to the Simple Features Specification for SQL of OGC. The implementation described in the Specification for SQL consists of an SQL extension using ADTs that supports storage, retrieval, query and updating of simple spatial features (points, lines and polygons). The spatial features are stored in geometrical primitives. Topological relationships between geometries can be retrieved by the use of spatial operators (see section 7.3). OGC Implementation Specification for SQL has so far been in 2D. Also the implementations of spatial data types in mainstream DBMSs are based on supporting 2D primitives in 2D and 3D space. With the implementations of the geometrical primitive it is possible to store and query spatial features in a DBMS, but the relationships between neighbouring spatial objects is not standardised and can only be determined with a geometrical query. Also the geometrical primitive causes redundancy in the case of a planar partition such as a cadastral map: shared edges and shared nodes are stored twice. In this section we distinguish between 2D (section 7.1.1) and 3D geometrical primitives (section 7.1.2). To illustrate how spatial objects can be maintained in DBMSs, Oracle Spatial 9i is used. Oracle Spatial 9i is not fully OGC compliant, since the spatial ADT as defined in Oracle differs slightly from the ADTs as defined by OGC. The OGC Implementation Specification for SQL defines separate data types for different types of geometry (points, linestrings, polygons etc.) while Oracle Spatial has only one data type for all types of geometry. Oracle is OGC compliant at level 1 (relational encoding of geometry) and not at level 2 (types and functions). However, the experiments show generic aspects for supporting geometry in a DBMS.

### 7.1.1 2D geometrical primitives in DBMSs

The supported spatial features in Oracle Spatial 9i are points, lines and polygons (including arcs, boxes and mixed geometry sets in 2D and 3D). The object relational model in Oracle defines the object type `sdo_geometry` as:

```

CREATE TYPE sdo_geometry
AS OBJECT (
SDO_GTYPE NUMBER,                type of the geometry (e.g. point,
                                  linestring, polygon)

SDO_SRID NUMBER,                 reference to the spatial
                                  reference system

SDO_POINT SDO_POINT_TYPE,        specific entry for pints

SDO_ELEM_INFO MDSYS.SDO_ELEM_INFO_ARRAY, indicates how the coordinate
                                  array should be interpreted

SDO_ORDINATES MDSYS.SDO_ORDINATE_ARRAY); list of coordinates

```

An example of using the Oracle object relational model to represent a polygon is shown in figure 7.1. In `sdo_gtype=2003`, the first position indicates the dimension (2D in this case), the last position indicates the element type (3 indicates a polygon). In `sdo_elem_info`, the combination '1003,1' indicates that this is a polygon containing straight lines ('1003' for polygon, and '1' for straight lines). The first position in '1,1003,1' ('1' in this case) indicates that the first (and only) element starts at offset 1 in the coordinate list.

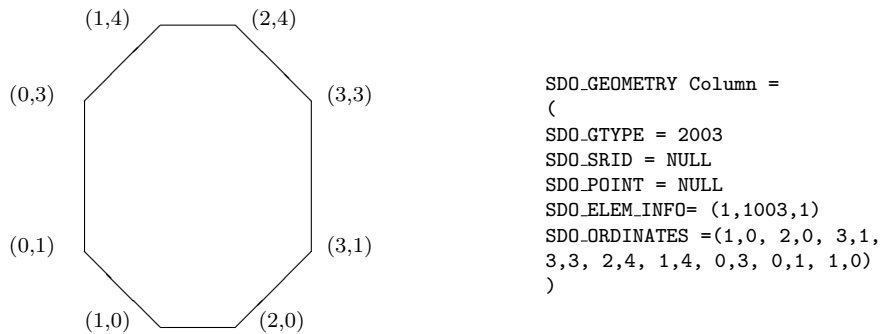

Figure 7.1: *Example of storing a polygon using Oracle's spatial data type.*

The next SQL statements illustrate how a box with 0,0 as lower-left and 100,100 as upper-right coordinates is stored in Oracle (`sdo_geometry` type) in the 'geom2d' table. Another way to represent a box is with a special element type in the `sdo_elem_info` array by which only the lower-left and upper-right coordinates are needed (which is not illustrated in this example).

```

/* creation of the table */
CREATE TABLE geom2d (shape mdsys.sdo_geometry not null, ID number(11) not null);

/* inserting data (2D box) */
INSERT INTO geom2d (shape,id)
VALUES (
mdsys.SDO_GEOMETRY(2003, NULL, NULL,
mdsys.SDO_ELEM_INFO_ARRAY(1, 1003, 1),
mdsys.SDO_ORDINATE_ARRAY(0,0, 100,0, 100,100, 0,100, 0,0)
), 8);

```

Besides the tables representing the geometries of the objects, metadata can be maintained describing the dimension, lower and upper bounds and tolerance in each dimension. In the following statements the information on the table `geom2d` is inserted in the metadata table. Finally, a spatial index (in this case R-tree, but a Quad-tree spatial index is also possible in Oracle Spatial) is created on the table (to speed up spatial queries). A spatial index can only be built when metadata has been inserted for the specific table:

```
/* inserting metadata, 2D table*/
INSERT INTO user_sdo_geom_metadata VALUES
('GEOM2D', 'SHAPE', mdsys.sdo_dim_array(
mdsys.sdo_dim_element('X', 0, 500, 0.5),
mdsys.sdo_dim_element('Y', 0, 500, 0.5) ), NULL);

/* creating index */
CREATE INDEX geom2d_i ON geom2d(shape) INDEXTYPE IS mdsys.spatial_index;
ANALYZE TABLE geom2d COMPUTE STATISTICS;
```

### 7.1.2 3D geometrical primitives in DBMSs

2D primitives are also supported in 3D space, for example a `'geom3d'` table can be created by the following query in Oracle:

```
/* creation of the table */
CREATE TABLE geom3d (
shape mdsys.sdo_geometry not null,
ID number(11) not null);
```

Note that the commands to create a 2D table and a 3D table are the same. The following query inserts the box as used in the 2D example with a height of 50:

```
/* inserting data, a 3D box *
INSERT INTO geom3d (shape, id) VALUES (
mdsys.SDO_GEOMETRY(3003, NULL, NULL,
mdsys.SDO_ELEM_INFO_ARRAY(1, 1003, 1),
mdsys.SDO_ORDINATE_ARRAY(0,0,50, 100,0,50, 100,100,50, 0,100,50, 0,0,50)
), 9);
```

Metadata can be inserted after which a spatial index (R-tree in 3D) can be created on the `'geom3d'` table:

```
/* inserting metadata, 3D table*/
INSERT INTO user_sdo_geom_metadata VALUES
('GEOM3D', 'SHAPE', mdsys.sdo_dim_array(
mdsys.sdo_dim_element('X', 0, 500, 0.5),
mdsys.sdo_dim_element('Y', 0, 500, 0.5),
mdsys.sdo_dim_element('Z', 0, 300, 0.5)
), NULL);

/* creating index */
CREATE INDEX geom3d_i ON geom3d(shape)
INDEXTYPE IS mdsys.spatial_index parameters('sdo_indx_dims=3');
ANALYZE TABLE geom3d COMPUTE STATISTICS;
```

Most DBMSs (including Postgres, IBM, Ingres and Informix) support the storage of points (0D), lines (1D) and polygons (2D) in 3D space as illustrated by this example, but not of 3D volumetric data types. However, volumetric objects can be stored in a geometrical primitive within current techniques using 3D polygons. 3D objects can be represented as polyhedra (body with flat faces) in two ways: as a set of polygons or as multipolygon (one object consisting of several polygons). To illustrate this, the cube in figure 7.2 has been used.

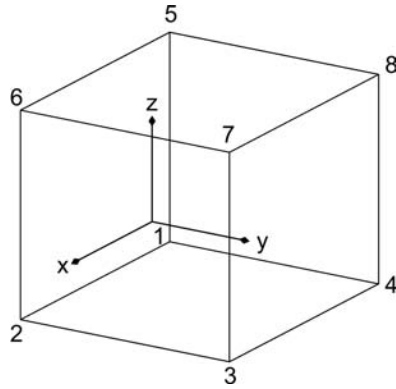

Figure 7.2: *Cube to be stored in the DBMS.*

In the first option (defining a 3D object as a set of 3D polygons) two tables are used: a table ‘BODY’ and a table ‘FACE’. In the table ‘BODY’ the 3D spatial object is defined by a set of records representing a polyhedron with references to the (flat) faces it consists of. In the table ‘FACE’ the actual geometries of faces are stored as polygons in 3D space (*sdo\_gtype*: 3003, *sdo\_elem\_info*: (1,1003,1)). This structure is partly a topological structure, since the body is defined by references to the faces and the faces can be shared by neighbour-bodies. However, shared edges and nodes are represented in every face they belong to, which leads to many redundant coordinates. The generated tables for the cube are shown in table 7.1 (*x1*, *y1*, *z1* refers to the *x*, *y* and *z*-coordinate of point 1 in figure 7.2).

In the second representation (defining a 3D object as a multipolygon) a body is stored as one record instead of a set of records. The multipolygon, which is also supported in

BODY		FACE	
<i>BID</i>	<i>FID</i>	<i>FID</i>	<i>sdo_ordinate array</i>
1	1	1 (lower face)	<i>x4,y4,z4, x3,y3,z3, x2,y2,z2, x1,y1,z1, x4,y4,z4</i>
1	2	2 (side 1)	<i>x3,y3,z3, x4,y4,z4, x8,y8,z8, x7,y7,z7, x3,y3,z3</i>
1	3	3 (side 2)	<i>x4,y4,z4, x1,y1,z1, x5,y5,z5, x8,y8,z8, x4,y4,z4</i>
1	4	4 (side 3)	<i>x1,y1,z1, x2,y2,z2, x6,y6,z6, z5,y5,z5, x1,y1,z1</i>
1	5	5 (side 4)	<i>x3,y3,z3, x2,y2,z2, x6,y6,z6, z7,y7,z7, x3,y3,z3</i>
1	6	6 (upper face)	<i>x5,y5,z5, x6,y6,z6, x7,y7,z7, z8,y8,z8, x5,y5,z5</i>

Table 7.1: *Tables representing a 3D cube using a set of 3D faces.*

Oracle Spatial, is used for this representation (sdo\_gtype: 3007, sdo\_elem\_info: (starting offset,1003,1)). This has also been implemented. The resulting table ‘BODY’, in which the cube of the example is stored, is shown in table 7.2.

An advantage of 3D multipolygons (compared to a set of polygons) is that they are identifiable as one object by front-end applications (GIS, CAD) that can access objects stored in the DBMS. Another advantage of the 3D multipolygon approach is the one-to-one correspondence between a record and an object. A disadvantage of both representations is that the topological structure between objects cannot be used, which implies risks for consistency as well as redundant storage of coordinates (and in the 3D multipolygon solution also of faces). Also topology within one object is not maintained. However, the main disadvantage of these implementations is that no true 3D geometrical primitive (as volumetric data type) is supported by the DBMS and therefore it is not recognised as such by the DBMS. In addition, functions on 0D, 1D and 2D primitives that are defined in 3D space project the primitives on a 2D plane (as will be illustrated in section 7.3.2).

These disadvantages can be overcome with the implementation of real 3D (volumetric) data types. In [198] an extension of Oracle Spatial 9i is proposed with support of a true 3D data type: the polyhedron primitive. This primitive has been implemented in this research including the data model, validation functions and spatial functions in 3D [5] (see section 7.4).

<b>BODY table</b>	
<i>Bodyid</i>	<i>Geometry</i>
1	SDO_GEOMETRY(3007, - 3007 indicates a 3D multipoly- gon NULL, NULL, SDO_ELEM.INFO_ARRAY( - offset of polygons is specified 1, 1003, 1, 16, 1003, 1, 31, 1003, 1, 46, 1003, 1, 61, 1003, 1, 76, 1003, 1 ), SDO_ORDINATE_ARRAY( x4,y4,z4, ,x3,y3,z3, x2,y2,z2, x1,y1,z1, x4,y4,z4, -end of 1st (lower) polygon x3,y3,z3, ,x4,y4,z4, x8,y8,z8, x7,y7,z7, x3,y3,z3, x4,y4,z4, ,x1,y1,z1, x5,y5,z5, x8,y8,z8, x4,y4,z4, x1,y1,z1, ,x2,y2,z2, x6,y6,z6, z5,y5,z5, x1,y1,z1, x3,y3,z3, ,x2,y2,z2, x6,y6,z6, z7,y7,z7, x3,y3,z3, x5,y5,z5, ,x6,y6,z6, x7,y7,z7, z8,y8,z8, x5,y5,z5 - end of last (upper) polygon ))

Table 7.2: Table representing a 3D cube using a 3D multipolygon.

## 7.2 Topological structure in DBMSs

Topological structures are generally used to represent planar or space partitions without redundancy and to represent (linear) networks. In this thesis (on cadastral registrations) the focus is on planar and space partition. Therefore linear networks will not be further considered. In planar partitions (2D topological structures) and space partitions (3D topological structures) spatial objects are defined on the basis of non-overlapping objects.

A large number of 2D topological structures are already available in literature, of which some have been implemented in commercial [97] and user-defined systems [136] and populated with data. Many 3D topological structures are also reported but only a few of them have been tested for large data sets, e.g. [243].

In general, many questions related to topological structures in relation to DBMSs still have to be resolved. How many and which primitives to store persistently? How many and which relationships to store explicitly? Is it sufficient to maintain the relationships to only low dimensional objects (edges and nodes in the case of polygons) or does the relationships to high dimensional objects (co-boundary relationships, e.g. edges that refer to their left and right polygon) also need to be maintained? In this respect, it is likely that a data model appropriate for a certain application may fail to serve another application. Thus a simultaneous maintenance of several topological structures in the DBMS might be needed. In [144], organisation of many topological structures in the DBMS is suggested by using a detailed description in a metadata table.

An extensive argumentation for the need to organise the topology support at DBMS level is provided in [144]. As specified there, a topological structure at DBMS level has many advantages:

- It avoids redundant storage (more compact than a full geometrical model).
- It is easier to maintain the consistency of the data after editing.
- It is more efficient during the visualisation in some types of front-ends, because less data has to be read from disk and transferred to clients.
- It is the natural data model for certain applications; e.g. during surveying an edge is collected (together with attributes to a boundary).
- It is more efficient for certain query operations (e.g. find neighbours).

An Implementation Specification for topological structures (complex features in OGC terms) is currently being developed by the OpenGIS Consortium in cooperation with ISO. A request for a proposal on this topic was issued in 2001 (and not updated since then) [151]. The request aimed at extending the interfaces in the OpenGIS Simple Features Implementation Specification. The new interfaces will build on the OpenGIS Simple Features Specification to address feature collections and more complex objects and concepts including curves and surfaces in 2D and 3D, compound geometries, arcs and circle interpolations and topology. Note that GML is able to model complex objects and 3D objects as defined in the OGC Abstract Specifications Topic 1.

In the current Implementation Specifications for Simple Features topological relationships can be derived by spatial operations on geometrical primitives (see also section 7.3.1).

Relational DBMS has proven that it can efficiently store the topological references: a face left and right of an edge, boundary to boundary references, treatment of islands, etc., i.e. the modelling aspect of topology. The problem with a standard relational DBMS, however, is that the declarative language SQL cannot handle the ‘navigational access’ needed to obtain the geometry of a topological primitive. In SQL it is not possible to express the statement: ‘follow the next references of the boundary until we are back at the beginning’. This functionality has to be provided by embedded queries using programming languages (able to ‘loop’ the data), e.g. PL/SQL (procedure language of Oracle) or Java. This functionality is however already available in every object oriented DBMS implemented within methods associated with classes. Currently, few user-defined and commercial implementations of topological structure in DBMSs exist using object relational technology. Also the next version of Oracle Spatial (10g) will have some support for topological structure.

To illustrate possibilities of topological structure in current DBMSs, this section describes a user-defined implementation of 2D topological structure (section 7.2.2) and a commercial solution (Laser-Scan Radius Topology [97]) (section 7.2.3). Both implementations represent a planar partition structure. First a description of planar partition topology according to both OGC and ISO is given (section 7.2.1). Like the 3D geometrical primitive, 3D topological structure has not (yet) been implemented as part of a DBMS. In section 7.1.2 a data structure was described in which the faces of a 3D body are geometrically described in a face table. The body table in this data structure contains references to the faces where the body consists of, but the data structure does not contain references to edges and nodes. In this data structure, bodies can share faces. Section 7.2.4 describes user-defined implementations of a full 3D topological structure.

### 7.2.1 OGC, ISO and planar partition topology

Spatial models defined by planar partitions are based on faces, edges and nodes. Polygon is the geometrical equivalent of the topological primitive ‘face’. This section describes how ISO and OGC define the feature ‘face’ and the geometrical equivalent ‘polygon’ in a planar partition topological structure.

#### ISO/TC 211

The ISO standard 19107 ‘Geographic information - Spatial schema’ defines geometrical primitives for which the code starts with ‘GM’, and related topological primitives, for which the code starts with ‘TP’. A `TP_FaceBoundary` consists of one or more `TP_Rings`. One of these rings is distinguished as being exterior of the boundary. Each ring is oriented so that the face is on its left, which means an anti-clockwise orientation for outer rings and a clockwise orientation for inner rings. A `TP_Ring` is used to represent a single component of a `TP_FaceBoundary`. It consists of a number of `TP_DirectedEdges` in a cycle. The `endNode` of a `TP_DirectedEdge` is the `startNode` of the next `TP_DirectedEdge`. Since `TP_Rings` are used in `TP_FaceBoundary` objects, the ring will be oriented so that the face is on its left.

According to the ISO/TC 211 standard a face is defined by edges and those edges are anti-clockwise oriented in case of outer rings (and clockwise in case of inner rings):



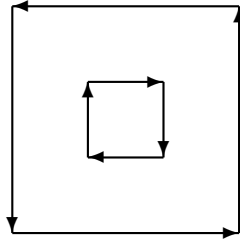

Every edge has a reference to the preceding and succeeding edge. The associated geometrical primitive of a face is ‘polygon’. From the specifications it is not clear whether the outer boundary of a polygon is allowed to touch itself, nor is it clear if inner rings can touch the outer boundaries or other inner rings [140]. However, since only one outer boundary is allowed, a polygon with two outer boundaries (defining potentially disconnected areas) is certainly invalid.

### OGC specifications for SQL

The ISO definition of the topology of a face is at the abstract level. As was stated before, the OpenGIS Consortium adopted the ISO Spatial Schema as Abstract Specifications and transformed these to the implementation level in the OpenGIS Simple Feature Specification for SQL.

Since the OpenGIS Specification for SQL does not define topology, we will have a look at the geometrical primitive of a polygon according to this Implementation Specification. A polygon is defined as a simple surface that is planar. A very precise definition of the polygon is given in the OGC specifications. The main characteristics from this definition relevant for the topology implementations described below is that rings may touch each other in at most a point. However, since polygons are built of LinearRings and since LinearRings are simple geometries, self-intersection of outer and inner rings is not allowed [140]. Inner rings, which divide the polygon into disconnected parts, are also not allowed. Note that the Simple Feature Specification does not say anything concerning the orientation of polygons.

## 7.2.2 User-defined DBMS implementation of 2D topological structure<sup>1</sup>

To explore the possibilities of using topology in spatial DBMS, a data set of cadastral parcels was selected, provided by the Netherlands’ Kadaster. This data set is modelled topologically in a relational DBMS, i.e. the geometry of the parcels is not stored explicitly, but can be inferred from the cadastral boundaries that are stored [136]. The most important tables are ‘boundary’ (cadastral boundaries) and ‘parcel’ (parcel identifiers). There is no need for the geometric data type ‘polygon’, because the area features (parcels) are stored topologically in the ‘parcel’ and ‘boundary’ table using the winged edge structure [7]. The edges in the boundary table contain references to other edges according to the winged edge structure, which are used to form the complete boundary chains (parcels). The edges in the winged edge structure also

<sup>1</sup>This section is based on [173].

contain a reference to the left and right parcel.

According to [136] there are a number of reasons why the Netherlands' Kadaster has chosen to maintain parcels in a topology structure:

- The approach allows calculations on correctness of topology after updates.
- It opens the possibility to relate attributes to the boundaries between parcels, e.g. date of survey, name of person locating the boundary, etc.
- If each parcel would be represented in the DBMS by a closed polygon, it would be complicated to represent the basic object of cadastral surveying: one boundary between two neighbour parcels.
- Closed polygon representation would lead to double (or triple or even more) storage of all coordinates (except the territorial boundary), which complicates data management in a substantial way.
- Closed polygon representation can result in the introduction of gaps and overlaps between parcels, which is not related to reality.

A parcel has exactly one reference to one of the surrounding boundaries and one reference to a boundary of each enclave. The structure of the topological references and the relationship between parcels and boundaries are visualised in figure 7.3.

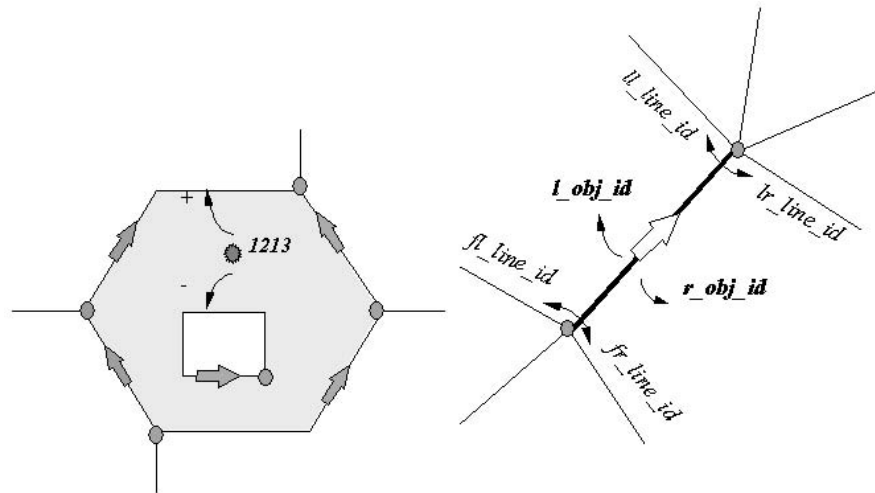

Figure 7.3: *Topological structure in the spatial DBMS of the Netherlands' Kadaster, taken from [136].*

The apparent disadvantage of storing spatial objects in a user-defined topological structure in the DBMS is that the DBMS is not aware of the geometry of spatial objects. Because there is no geometry attribute in the parcel table, it is for example not possible to calculate the area of a parcel or use the geometry of a parcel in overlap-functions. By extending the DBMS with a function that materialises (*realisation* in OCG terms) the geometry from the topological relationships it is possible to store data topologically and still use the spatial operations offered by the DBMS built on the geometrical model.

Therefore a function ‘return\_polygon’ has been implemented which realises the geometry of a polygon. The implementation is done in Oracle Spatial 9i. In order to get high performance and to avoid unnecessary conversions and data communication between DBMS and client, the return\_polygon function must be performed within the geo-DBMS itself. In Oracle Spatial 9i, this can be done by stored procedures or functions which work within the database. The stored procedures and functions can be written in PL/SQL and/or Java, both of them using SQL to access the data. With the help of the spatial index, spatial clustering and an index on the id’s of objects this should lead to good performance. The return\_polygon function can be used in an SQL-statement, e.g. in a query to compute the area of a parcel:

```
SELECT sdo_geom.sdo_area(return_polygon(object_id), 1) FROM parcel;
```

The function to realise the geometry of polygons has been implemented in two ways. The first solution uses only the information on the relationships between the preceding and succeeding edges. The second solution is based on the left-right information of edges. Both implementations will be described and compared in the next paragraphs of this section.

A function-based spatial index is created on the face of the parcels in order to optimise the performance. Since version 9i, Oracle has offered function-based indexes, i.e. an index which is created on the return value of a function in addition to a normal index created directly on the value of an attribute. A function based spatial index facilitates queries that use locational information of type sdo\_geometry returned by a function. The spatial index is created based on the pre-computed values returned by the function. This is implemented in Oracle 9i in two steps. First, the user\_sdo\_geom\_metadata table was updated (defining the lower and upper bounds and tolerance in each dimension) to specify the function name:

```
INSERT INTO user_sdo_geom_metadata VALUES(
'PARCEL', 'return_polygon(object_id)', mdsys.sdo_dim_array (
mdsys.sdo_dim_element('X', 82291, 84261, 0.0005),
mdsys.sdo_dim_element('Y', 453039, 455632, 0.0005)), NULL);
```

The next step is to create a spatial index by specifying the function name and parameters. For example, creating an R-tree index, is done with the following SQL-statement:

```
CREATE INDEX parcel_idx ON parcel(return_polygon(object_id))
INDEXTYPE IS mdsys.spatial_index;
```

Without a function-based spatial index it would not have been possible to properly index the faces. During an overlap query or any other query using the spatial index, objects are filtered by means of this index. That is, using the pre-computed bounding boxes which are stored in the R-tree. Then the return\_polygon function is executed to obtain the complete geometry of filtered objects to be used in the exact overlap test. The return\_polygon function depends on the values in other tables. Therefore when the index is built it contains the results of evaluating the function as at the time of index build. If the function does not produce the same results next time it is evaluated, the index search algorithm will give the wrong results. Therefore the index needs to be rebuilt each time an update is done that affects the bounding box of any

parcel. A trigger on the edge updates could probably do the job to also update the appropriate index entries in the R-tree. However, this was not tested.

### **Realising geometry of polygons based on relationships between edges**

The function `return_polygon` based on the relationships between edges has been implemented in PL/SQL. The function starts with the table ‘parcels’ and uses the ‘boundary’ table. The function creates a polygon geometry, of which the orientation is valid according to the Oracle Spatial (and OGC) rules: the coordinates of the outer ring are listed in anti-clockwise order and the coordinates of the enclaves are listed in clockwise order. In the data set the winged edge structure is defined in both directions, since every boundary contains a reference to its four connecting boundaries (which is dissimilar to the ISO definition that only define references to the succeeding and preceding edge).

The relevant attributes in the ‘parcel’ table used in the construction of polygons are:

- `object_id`: the unique identifier of parcels;
- `line_id1`: reference to one of the surrounding boundaries (stored in the boundary table);
- `line_id2`: reference to one of the boundaries of the first enclave (also stored in the boundary table).

If there is more than one enclave the ‘parcelover’ table is used. The relevant attributes in this table are:

- `object_id`: the unique identifier of parcels;
- `line_id1`: reference to one of the boundaries of the second enclave;
- `line_id2`: reference to one of the boundaries of the third enclave;
- .....
- `line_id10`: reference to one of the boundaries of the eleventh enclave.

These `line_id`’s contain also references to a line in the boundary table. If a parcel has more than eleven enclaves, the `parcelover` table has more than one entry for that `object_id`. Consequently the attribute ‘`line_id1`’ in the `parcelover` table may refer to the second, the twelfth, the twenty-second etc. enclave, the attribute ‘`line_id2`’ may refer to the third, the thirteenth, the twenty-third etc. enclave, etc.

The relevant attributes in the ‘boundary’ table in LKI are:

- `object_id`: unique identifier of boundaries;
- `geo_polyline`: geometry of the line;
- `fl_line_id`: reference to the first line on the left, seen from the middle point of the line, looking back to the beginning;
- `ll_line_id`: reference to last line on the left, seen from the middle point of the line, looking towards the end;
- `fr_line_id`: reference to the first line on the right, seen from the middle point of the line, looking back to the beginning;
- `lr_line_id`: reference to last line on the right, seen from the middle point of the line, looking towards the end;

- l\_parcel: parcel that is located at the left-hand side from the directed boundary (when looking from the beginning to the end of the boundary);
- r\_parcel: parcel that is located at the right-hand side from the directed boundary (when looking from the beginning to the end of the boundary).

Note that these references are different from those in figure 7.3. In figure 7.3 the references at the start of the edge are ‘left’ or ‘right’ seen from the starting point of the edge. In contrast, in the data set these references are ‘left’ or ‘right’ seen from the middle point of the edge and therefore they are reversed (which is the Dutch interpretation of the winged edge structure).

How the function works, will be illustrated with an example in which the polygon of parcel 603 is realised (see figure 7.4). The attributes of line\_id1 and line\_id2 in the parcel table are:

```
SELECT object_id, parcel, line_id1, line_id2 FROM parcel WHERE parcel=603;
```

OBJECT_ID	PARCEL	LINE_ID1	LINE_ID2
310148953	603	310439663	0



Figure 7.4: Parcel 603 and 973 are used in the examples.

The parcel has one reference to its outer boundary (i.e. line\_id1) and no enclaves (because line\_id2=0). The polygon of the parcel can now be constructed by starting with the first boundary, with object\_id=310439663. The boundary table is queried to look for the coordinates of this boundary and to look for the boundaries that are connected to it in anti-clockwise direction. This step is repeated until the first boundary is found again. To avoid a select statement having to be performed for every next boundary, first all boundaries together with the relevant attributes, which have parcel 603 on their right-hand or left-hand side, could have been selected (see figure 7.5 and the query below). However, the implementation of the function described here only uses the ‘connect’ information, while the implementation as described in the next session only uses the left-right information.

```
SELECT object_id, fl_line_id, fr_line_id, ll_line_id, lr_line_id, l_parcel, r_parcel
FROM boundary WHERE l_parcel=603 OR r_parcel=603;
```

OBJECT_ID	FL_LINE_ID	FR_LINE_ID	LL_LINE_ID	LR_LINE_ID	L_PAR	R_PAR
310547374	310419672	-310419673	310594168	310439663	973	603
310419672	-310419673	310547374	310518755	310419671	603	960
310518755	310419671	-310419672	-310439663	310439732	603	605
310439663	-310547374	310594168	310439732	-310518755	960	603

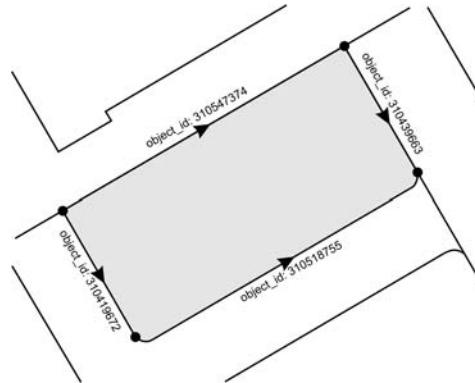

Figure 7.5: Id's and direction of boundaries of parcel 603.

After having followed all edges of the outer ring the polygon can be constructed by connecting all line strings of the resulting boundaries. In this process the line strings, which are oriented in clockwise order (referred to with a minus), need to be reversed. The polygon geometry is realised in such a way that the coordinates at connection points are stored only once, and polygons are closed (first and last point is repeated). The collected geometry information is returned as a spatial data type of Oracle (polygon).

Now we will look at a polygon with enclaves: parcel 973 (see figure 7.4). As can be seen from line\_id2, parcel 973 has at least one enclave, starting with the boundary with object\_id 310376490 (line\_id2):

```
SELECT object_id, parcel, line_id1, line_id2 FROM parcel WHERE parcel=973;
```

OBJECT_ID	PARCEL	LINE_ID1	LINE_ID2
310152502	973	-310419676	310376490

The realisation of the outer boundary of the polygon is performed in the same way as in the first example and will not be explained here. Parcel 973 contains one or more enclaves (line\_id2 > 0). Therefore the rings of the enclaves need to be constructed in clockwise direction according to ISO and Oracle rules. The first enclave starts with the boundary with object\_id 310376490 (line\_id2). In principal we can follow the same procedure as in the case of the outer boundary: create a list with all connecting arcs (this time in clockwise order) to realise the geometry of the enclave.

The geometry of enclaves is constructed in the same way as the geometry of outer boundaries: linestrings are connected, duplicate coordinates are removed, linestrings in anti-clockwise direction are reversed and the polygon is closed. To see if this parcel has more than one enclave the ‘parcelover’ table is checked:

```
SELECT * FROM parcelover WHERE object_id IN (SELECT object_id
FROM parcel WHERE parcel=973);
```

LINE_ID1	LINE_ID2	LINE_ID3	LINE_ID4	LINE_ID5	.....	LINE_ID10
-310379237	-310205718	0	0	0	.....	0

The result is two more enclaves. The enclaves are generated in the same way as the first one. Again, the collected geometry information of enclaves together with the geometry of the outer boundary is inserted in the spatial data type of Oracle to create the polygon geometry of the parcel in Oracle.

### Realising geometry of polygons based on left-right information

The alternative version of the ‘return\_polygon’ function uses only the left-right information stored with every parcel boundary and a geometrical comparison to find and join connected boundaries in a ring. Here the boundaries that have the given parcel to the left or right are selected. By repeatedly joining boundaries that end in the same endpoint, we end up with the boundary of the complete parcel. Enclaves are realised in the same way. At the end of the procedure it has to be detected which of the rings defines the outer boundary and which of the rings define enclaves.

The attributes in the ‘boundary’ table that are used by the algorithm are:

- geo\_polyline: geometry of the line;
- l\_parcel: parcel, located at the left-hand side from the directed boundary;
- r\_parcel: parcel, located at the right-hand side from the directed boundary.

The function has been implemented in the Java programming language and is integrated in the database server. The function accesses the database tables via an internal JDBC connection.

The first step is to retrieve all boundary lines that are part of the parcel:

```
SELECT geo_polyline FROM boundary WHERE l_parcel = 973 OR r_parcel = 973;
```

This query results in a collection of LineStrings. What needs to be done now is to glue these LineStrings together in such a way that they form an ordered collection of rings. This is done using two data structures:

- Rings: In this variable we collect the completed LinearRings (LineStrings that form a loop) that are formed during the algorithm.
- Graph: The graph structure contains all LineStrings that still need to be combined to form loops. The graph contains vertices (nodes) and edges. The endpoints of the LineStrings form the nodes of the graph. The edges in the graph are formed by the LineStrings and run between two nodes, being the startpoint and the endpoint of the LineString.

The algorithm first fills the graph structure and then tries to move all LineStrings from the graph into the ring structure from which the result is constructed.

```
// 1. Initialization.
for (all LineStrings that belong to the parcel boundary)
{
    Insert the LineString into the graph.
}

// 2. Main Loop.
while (graph contains a node with two edges)
{
    Delete the node and the two edges from the graph.
    if (the two edges at the node are the same edge)
    {
        we have found a loop and add the edge to the rings.
    }
    else
    {
        glue the two LineStrings together to form one big LineString.
        Insert the new LineString into the graph.
    }
}

// Now the graph should be empty. If this is not the case, the input
// data was incorrect.

// 3. Construct Polygon from rings.

Find the ring which encloses the largest area.
This is the outer boundary assuming that the input data is correct.
The rest of the rings are enclaves.
Construct a polygon using the boundary and the enclaves.
Calculate the orientation and return the polygon as Oracle's spatial data type.
```

### Discussion on self-implemented return\_polygon function

The performance of both implementations is of course dependent on the complexity of the data: the more points in a boundary, the worse the performance, also the more boundaries in a polygon the worse performance. Also the following of pointers as in the implementation based on the relationships between edges is not very compatible with the relational model, since it leads to “row at a time” processing. This also causes response time issues with increasing boundaries in a polygon. To test these statements we did some tests of which one of the results is shown in figure 7.6.

On the x-axis of this figure the number of points in the resulting polygon are shown, on the y-axis the construction time per polygon in seconds. For both implementations the trend is visible of increasing construction time when the number of points in the resulting polygon increases. This trend is more apparent in the left-right implementation. Probably this is due to the fact that in the left-right implementation the boundaries are connected by finding common points. In this process computational costs increase with the number of points. Since the left-right method has been implemented in Java and the method based on relationships between edges in PL/SQL the performance of both methods cannot be compared. Apart from performance, the implementations differ in the underlying geometrical primitive. In the relationships-between-edges implementation, the outer ring of a face can touch itself on the outer boundary at exactly one point, and in the left-right implementation this is not possible. This difference can be illustrated by the polygon shown in figure 7.7: a polygon that has an island that touches the boundary at exactly one point. The relationships-



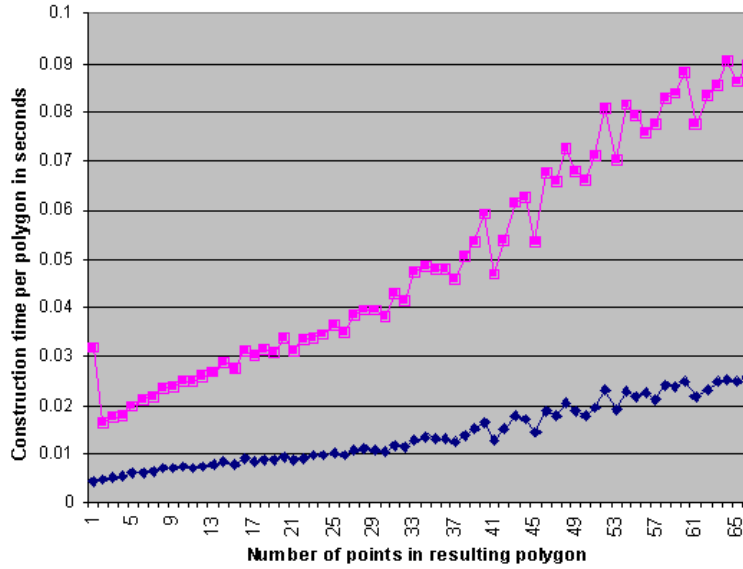

Figure 7.6: Construction time per polygon for different number of points in the resulting polygon. The black line represents the implementation based on the relationships between edges and the grey line represents the left-right implementation.

between-edges algorithm will generate a polygon with one self-touching outer ring, while the left-right algorithm will return a polygon with a boundary and an island. As was described in section 7.2.1, a self-touching boundary is not allowed according to the OpenGIS Specification for SQL and not valid according to Oracle (rings may only touch other rings). Therefore the relationships-between-edges method returns a non-valid geometry according to OGC and Oracle rules. Post-processing invalid polygons is possible, but requires so much geometrical and topological calculation that it is easier to use the left-right topology. From this it can be concluded that the winged edge structure as implemented in the cadastral data set is not OGC compliant, but also the OGC standard might need to be refined.

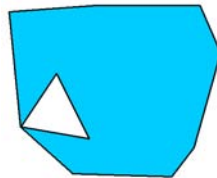

Figure 7.7: A polygon with a hole that touches the boundary.

### 7.2.3 Commercial DBMS implementation of 2D topological structure

Compared to user-implemented models, the implementation of topology structure in Laser-Scan Radius Topology [97], which is based on Oracle Spatial, is much more developed. It is a ‘complete’ implementation of topology with support for linear networks and planar topology, including updates, insertions and deletions.

To retrieve geometry from a topologically structured data set, Radius offers a function ‘get\_geom’ that is equivalent to the ‘return\_polygon’ function of our own implementations. Most users however choose not to use this function, but instead store a copy of the geometry explicitly. This increases the storage requirements, but it means that there is no performance penalty when accessing geometries (e.g. for display or geometric queries) since the geometry is instantly available and does not have to be computed. The use of database triggers in the Radius Topology architecture ensures that the geometries and their topological representation are always synchronised.

Additionally support for topological querying (containment, adjacency, connectivity, overlap) is available in Radius Topology by means of a `topo_relate` operator.

All required topological references are stored explicitly: the winged edge representation (in the edge-to-edge table) makes up just a small part of the complete system (see figure 7.8). Topological primitives are stored in the `NODE`, `EDGE` and `FACE` tables while faces are only stored by references to edges. A number of reference tables are used to store various types of topological references. The `TOPO` table is the link between the features and the topological structures. Topology is organised in ‘manifolds’. Associated with each manifold and with the system as a whole are some metadata and error tables. Before topologically structuring data in Radius Topology, the user can specify rules in order to control the way the structuring works (snap tolerances, which features/primitives are moved and which stay while snapping, etc).

In [108] a performance test is described in which the topological structure of Laser-Scan Radius Topology (version 1.0) was compared to the geometrical primitive of Oracle Spatial 9i. In the topology case less points are stored (by avoiding storing ‘common’ boundaries twice). However disk space requirements are much bigger in the topological case due to the increased number of topological primitives and the references between them compared to the number of area features (and the way geometry is implemented in Oracle Spatial: small objects have relatively much overhead).

The total storage requirement for topology is intended for references, id’s and associated indexes that are required for the Radius Topology structure. The storage requirement will probably be more favourable for topology in the case of smaller scale data and data with a relatively high number of intermediate points in the boundaries.

From the tests described in [108] it can be concluded that performance of geometrical querying on a data set structured with Radius Topology is slower. This is due to the cost of computing the geometries on-the-fly from the topological information. This occurs when geometries are not stored explicitly alongside the topology. For this reason users often store the geometries explicitly as described above.

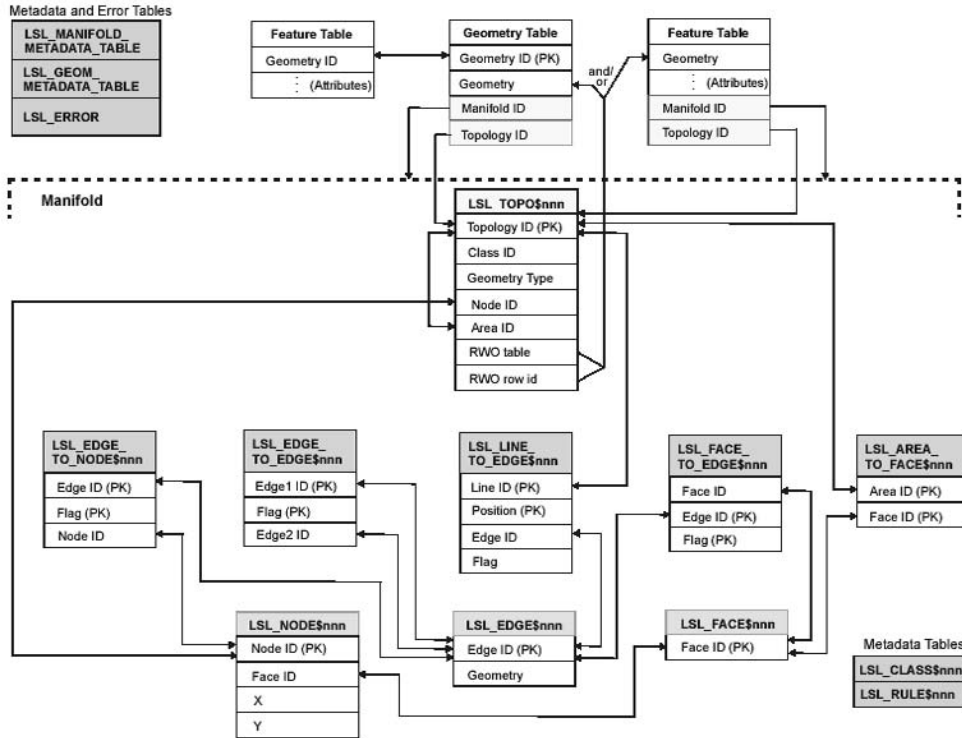

Figure 7.8: *Radius Topology database tables (version 1.0), taken from [98].*

### 7.2.4 User-defined DBMS implementation of 3D topological structure

In 3D, there is yet no consensus on a single topological structure. Different topological structures can be defined depending on the number of primitives to maintain, and also the number and nature of relationships to explicitly store. The problems of defining 3D topological structures are relatively many compared to 2D. Due to the large amounts of data and higher complexity, one data structure representing a specific topological structure, which is appropriate for a certain application, may not be easy to serve another application. Unfortunately, 2D topological structures are not directly extendable to 3D. 2D structures are mostly built around the properties of an edge. One edge has exactly two neighbouring nodes (begin and end) and exactly two neighbouring faces (left and right). This property is not true in 3D space. An edge can have more than two neighbouring faces, i.e. the order of the faces has to be specified.

Since the 3D topological structure of Zlatanova [240] is one of the few implementations of a topological structure defining volumetric objects, and since the implementations showed good results [30, 244], we had a closer look at this model. The Simplified Spatial Model (SSM) is a typical boundary representation. The role of the edge

(=boundary) in 2D is now the role of the face (=boundary) in 3D. Nodes describe faces, faces describe bodies. The 1D primitive as part of a body (edge), is not explicitly stored in the model (see figure 7.9). Shared faces and nodes are only stored once. This 3D topological structure is described in detail in [240].

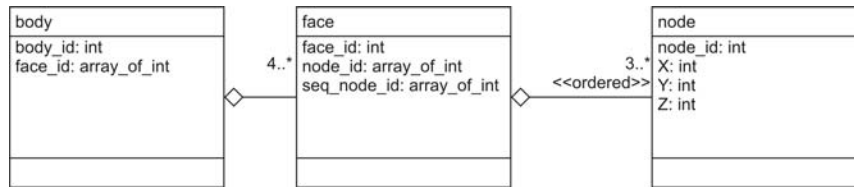

Figure 7.9: UML class diagram of Simplified Spatial Model [240].

This 3D topological structure can be implemented in several ways in an object relational DBMS. The first approach is the relational implementation. The conceptual model can be converted directly into a relational data model. For each object (node, face, and body) a separate relational table is created. The NODE table contains the id of the node and the three coordinates of the points. The FACE table contains the id of the face, a column denoting the order (anti-clockwise) of the nodes in a face and the id's of nodes that the face consists of. A BODY table contains references to the id's of faces it consists of. Since the relationship between a face and constituting nodes (and between a body and constituting faces) is one-to-many, multiple rows (or columns) represent one face (and one body) in a traditional relational implementation using only plane relational tables and traditional data types. In the multiple-column representation the number of columns is fixed and a high number of columns has to be chosen in order to be able to represent also faces with a large number of nodes and bodies with a large number of faces. This leads to a table with large amounts of zero fields and consequently to overhead of information. Multiple-row representation is therefore preferred. The same is true for the relationship between body and faces.

Another possibility is the object relational implementation. The list of id's referring to lower dimensional objects (faces, nodes) is stored in a single column. This means that the number of rows in the object table is reduced to the actual number of the higher dimensional object (body, face). Object relational implementation is a two-step procedure, i.e. creating objects (ADTs) and creating tables. The object relational implementation of 3D topological structure is illustrated with Oracle Spatial 9i. Two extended Oracle data types are used, which are intended for representing the one-to-many relationship, i.e. varrays (variable arrays) and nested tables. The syntax of the commands to create a data type of type varray is:

```
CREATE TYPE NodeArray AS varray (10000) OF number (5);
```

Utilising the newly created data type NodeArray, the FACE object can be stored in the database in the following way:

```
CREATE TABLE face
(fid NUMBER(11) NOT NULL, num NUMBER(11) NOT NULL, nids NodeArray NOT NULL);
```

The other method to represent one-to-many relationships using only one column is nested tables. The commands to create a data type of type table and to use this new data type in the FACE object are:

```
CREATE TYPE NodeTable AS table OF number(5);
CREATE TABLE FACE (
FID number(11) not null,
NUM number(11) not null,
NIDS NodeTable not null);
```

As can be concluded from [244], the nested table shows slower performance than the tables with varrays. This is probably due to the fact that nested tables are less efficient than varrays because more overhead is produced during the implementation.

To be able to use the spatial operations of the DBMS on topologically structured data, a realisation function was written. This function realises the geometry of the 3D spatial objects, based on the topological tables. The function is based on the relational implementation. In the function the nodes of one 3D spatial object are retrieved by the following query:

```
/* for the body bid=1 */
SELECT body.bid,face.fid, face.seqn, node.nid, node.x, node.y, node.z
FROM body, face, node
WHERE body.fid=face.fid AND face.nid=node.nid AND body.bid=1;
```

After this, the obtained nodes are translated to either a complex geometrical object of 3D polygons, a 3D multipolygon (see section 7.1.2), or a polyhedron primitive (see section 7.4).

## 7.3 Spatial analyses in DBMSs

Spatial analyses in the context of a DBMS are related to operations that are performed on spatial objects (in vector-format) in which often no distinction is made between the spatial and thematic components of spatial objects. In this section we will concentrate on the part of spatial analyses that is only related to the spatial component.

The Abstract Specifications of OGC distinguish between two sets of operations (also called operators or functions) defined for both geometrical and topological primitives while some of them are identical. The operations can be classified as unary (performed on one object) and binary (performed on two objects). For example, fifteen unary (mbRegion, representativePoint, boundary, closure, isSimple, isCycle, distance, dimension, coordinateDimension, maximalComplex, transform, envelope, centroid, convex hull, buffer) and seven binary relations (contains, intersects, equals, union, intersection, difference, symmetricDifference) are suggested within the geometry schema. Within the topology schema the unary operations are seven (dimension, boundary, coBoundary, interior, exterior, closure, maximalComplex). The binary operations for the topology schema can be a different number depending on the used formalism for detecting relationships. Three frameworks are accepted as fundamental: Boolean set of operations (considering intersections between closure and exterior),

Egenhofer operations (taking into account exterior, interior and boundary of objects) [49] and Clementini operations using the same topological primitives as Egenhofer but considering the dimension of the intersection [24]. It should be noticed that the Abstract Specifications do not discuss implementation environments. The current Implementation Specification for SQL [148] specifies eight relationships based on the Egenhofer framework, i.e. equals, disjoint, intersects, touches, crosses, within, contains and overlaps, which are only defined for Simple Features, i.e. geometry.

In this section spatial analyses in DBMS are considered, distinguishing between spatial analyses on geometrical primitives (2D in section 7.3.1 and 3D in section 7.3.2) and spatial analyses on a topological structure (section 7.3.3). In section 7.3.4 a case study is described which compares the same spatial analysis (using the same test area) performed on geometrical primitives on the one hand and on a topological structure on the other hand.

### 7.3.1 2D spatial analyses using geometrical primitives

The OGC Simple Feature Specification for SQL [148] describes geometrical and topological functions that should be supported at DBMS level as part of the implementation of the geometrical primitive. The defined operations to obtain the topological relationships do not give the dimensionality of the relationship as a result. For example the query ‘Find all adjacent parcels to a query parcel’ (using the touch relationship), gives all parcels that touch with the query parcel as a result regardless the dimensionality (touch at edge or point). To restrict the result data set to only parcels that touch at an edge, the query should be extended with the condition that boundaries of two parcels should also overlap. Overlap results ‘true’ if the intersection results in geometry of the same dimension as the input geometries.

In Ingres the support for topological relationships is minimal. Oracle, IBM DB2, Informix and PostGIS support geometrical and topological functions defined by OGC and often more functions than these as reported in [139].

Oracle Spatial 9i is used to illustrate the possibilities of spatial analysis using the geometrical primitive in DBMSs. Currently, Oracle Spatial supports three groups of selection operations, i.e. topological relationship operations, metric operations and specialisation operations.

Topological relationship operators between two geometries are implemented with respect to the nine-intersection model of Egenhofer [49]. The names of the operations slightly differ from the ones suggested by OGC. In Oracle Spatial 9i all these topological relationships are implemented using one function (`sdo_geom.relate`) or operator (`sdo_relate`), where the type of relationship is passed as a text string (table 7.3, left). The spatial operator requires and utilises a spatial index and is therefore faster than the spatial function, which also work without a spatial index.

In the Egenhofer model each spatial object has an interior, a boundary, and an exterior. The boundary consists of points or lines that separate the interior from the exterior. The boundary of a line consists of its end points. The boundary of a polygon is the line that describes its perimeter. The interior consists of points that are in the object but not on its boundary, and the exterior consists of those points that are not

Topological operations		Metric and specialisation operations	
OGC	Oracle	OGC	Oracle
		<i>Unary metric operations</i>	
equals	equal	Area	sdo_area
disjoint	disjoint	Length	sdo_length
intersects	anyinteract	<i>Unary specialisation operations</i>	
touches	touch	Buffer	sdo_buffer
crosses	overlapbdisjoint	Convexhull	sdo_convexhull
within	inside	Centroid	sdo_geomcentroid
contains	contains	Boundary	sdo_mbr
overlaps	overlapbdisjoint	<i>Binary metric operations</i>	
	coveredby	Distance	sdo_distance
	covers	<i>Binary specialisation operations</i>	
	on	Intersection	sdo_intersection
		Union	sdo_union
		Difference	sdo_difference
		Symdifference	sdo_xor

Table 7.3: *Topological, metric and specialisation operations in the DBMS according to Implementation Specifications of OGC and the Oracle Spatial implementations.*

in the object. Some of the topological relationships of the 9-intersection model have names associated with them that specify the type of relationship, e.g. `INSIDE` and `COVEREDBY`. `INSIDE` returns true if the first object is entirely within the second object and the object boundaries do not touch, otherwise, it returns false. `COVEREDBY` returns true if the first object is entirely within the second object and the object boundaries touch at one or more points, otherwise it returns false.

Besides the relationship operations, many metric and specialisation operations are proposed by OGC that can take one (unary operations) or two geometries (binary operations), or other parameters (e.g. buffer size) and calculate some values or new geometries. The most important of them together with their Oracle equivalents are given in table 7.3, right. An example is when one wants to obtain a new geometry that is the intersection between the geometry of parcels and the geometry of the extent of a tunnel. The query to create these new geometries is the following (to speed up this query a ‘where’ clause could be added using ‘anyinteract’):

```
CREATE TABLE new_geometry AS
SELECT t.object_id, p.parcel_number, sdo_geom.sdo_intersection(t.shape, p.shape, 1) shape
FROM parcel p, tunnel t;
```

Another class of spatial operations in Oracle Spatial returns an aggregate of a collection of geometries. These are not defined within OGC (see table 7.4).

SDO_AGGR_CENTROID	Returns a geometry object that is the centroid (“center of gravity”) of the specified geometry objects
SDO_AGGR_CONVEXHULL	Returns a geometry object that is the convex hull of the specified geometry objects
SDO_AGGR_MBR	Returns the minimum bounding rectangle of the specified geometry objects
SDO_AGGR_UNION	Returns a geometry object that is the topological union (OR operation) of the specified geometry objects

Table 7.4: *Examples of aggregate functions in Oracle Spatial 9i.*

### 7.3.2 3D spatial analyses using geometrical primitives

Our experiments showed that it is possible to maintain objects with 3D coordinates in Oracle Spatial 9i (see section 7.1.1). However, the current implementations of geometry operators (e.g. compute area of 3D polygon) in Oracle Spatial 9i omit the z-value.

In the following example, a table (geom) is created in Oracle Spatial 9i in which a 2D polygon and a polygon defined in 3D space are inserted. After that, the geometrical operators area and length (perimeter) are performed on both polygons. The operator ‘validate’ is performed to show that the polygons are both valid. As can be seen in the results of the queries, sdo.area and sdo.length (both spatial operators in Oracle) return the same value for both polygons, although the 3D polygon actually has a greater area and length (perimeter). In these calculations, the 3D polygon is projected on the surface.

```

/* 66: a 2D polygon */
INSERT INTO geom (shape,tag) VALUES (mdsys.sdo_geometry(2003, NULL, NULL,
  mdsys.sdo_elem_info_array(1, 1003, 1),
  mdsys.sdo_ordinate_array(12,15, 15,15, 15,24, 12,24, 12,15)), 66);

/* 88: a 3D polygon */
INSERT INTO geom (shape,TAG) VALUES (mdsys.sdo_geometry(3003, NULL, NULL,
  mdsys.sdo_elem_info_array(1, 1003, 1),
  mdsys.sdo_ordinate_array(12,15,0, 15,15,0, 15,24,999, 12,24,999, 12,15,0)), 88);

SELECT tag,
sdo_geom.sdo_area(shape, 1) area,
sdo_geom.sdo_length(shape, 1) length
sdo_geom.validate_geometry(shape, 1) geom_validate
FROM geom;

```

TAG	AREA	LENGTH	GEOM_VALIDATE
----	----	-----	-----
66	27	24	TRUE
88	27	24	TRUE

Many other DBMSs support a similar set of geometry operators as most of them also skip the z coordinate. Some exceptions are PostGIS (PostgreSQL) [171] and



the MapInfo Spatialware Datablade [113] (based on Informix) that do have limited support for geometry calculation in 3D, such as length and perimeter in 3D. This is illustrated in the next PostGIS example.

First, four tables are created: line2D, line3D, polygon2D and polygon3D in which respectively a 2D line, a 3D line, a 2D polygon and a 3D polygon are inserted ('g' in PostGIS is used to end a command):

```
/* a table with a 2D line */
CREATE TABLE line2d (id int4)\g
SELECT addgeometrycolumn('test','line2d','shape',0,'LINESTRING',2)\g
INSERT INTO line2d (id, shape) VALUES(1,
geometryfromtext('LINESTRING(1 1,2 2)',0))\g

/* a table with a 3D line */
CREATE TABLE line3d (id int4)\g
SELECT addgeometrycolumn('test','line3d','shape',0,'LINESTRING',2)\g
INSERT INTO line3d (id, shape) VALUES(1,
geometryfromtext('LINESTRING(1 1 0,2 2 50)',0))\g

/* a table with a 2D polygon */
CREATE TABLE polygon2d (id int4)\g
SELECT addgeometrycolumn('test','polygon2d','shape',0,'POLYGON',2)\g
INSERT INTO polygon2d (id, shape) VALUES(1,
geometryfromtext('POLYGON((0 0, 1 0, 1 1, 0 1, 0 0))',0))\g

/* a table with a 3D polygon */
CREATE TABLE polygon3d (id int4)\g
SELECT addgeometrycolumn('test','polygon3d','shape', 0,'POLYGON',3)\g
INSERT INTO polygon3d (id, shape) VALUES(1,
geometryfromtext('POLYGON((0 0 0, 1 0 0, 1 1 100, 0 1 100, 0 0 0))',0))\g
```

In the next step the following queries are executed:

```
SELECT length(shape) FROM line2d\g
SELECT length3d(shape) FROM line3d\g
SELECT perimeter(shape) FROM polygon2d\g
SELECT perimeter3d(shape) FROM polygon3d\g
```

As the results show, length and perimeter do work in 3D:

```
length      1.4142135623731 (1 row)
length3d    50.0199960015992 (1 row)
perimeter   4 (1 row)
perimeter3d 202.009999750012 (1 row)
```

The other functions (overlap, area, distance) in PostGIS (and also in the SpatialWare Datablade of MapInfo) are performed in 2D. PostGIS also has a box3D function that gives the maximum extents in 3D as result.

### 7.3.3 Spatial analyses using the topological structure

Some spatial operations are specific to topological structure, for example validation functions on topological structure (e.g. is loop closed?) and network computation

(e.g. find shortest path). Another spatial operation specific to topological structure is realisation of geometry, which is the basis for nearly all metric operations and needed for visualisation of the objects. The complexity of the realisation functions considerably varies with respect to the different implementations of the topological structure. For example the geometry (coordinates) of a body can be extracted by only one SQL statement (in case of relational implementation) if the geometry is maintained explicitly, but a PL/SQL script is required if the body is represented as a variable array of id's of faces and the coordinates are only stored at node level.

Although not yet very common, spatial analysis on topological structure is available in some DBMS software (e.g. Laser-Scan Radius, Oracle Spatial 10g) but the support is still limited. A lack of native topology support of DBMS is compensated by many user-defined implementations of topological structure. Each implementation has its own set of topological operations available with the model. It depends on the topological structure and thus on the relationships defined in the topological structure which topological operations are available. For example if a topological structure of planar partition is implemented with only information on connecting edges, without information on the left and right face of an edge, an adjacent analysis (give all polygons adjacent to this polygon) cannot be performed on the topologically structured data. Therefore, first the geometries of polygons have to be realised and the analysis has to be performed on the geometrical primitive.

We have developed several functions to realise geometry (PL/SQL and Java) related to two different topological structures, i.e. winged edge (in 2D, section 7.2.2), and SSM (in 3D, section 7.2.4). Both topological structures were user-defined implementations in a object relational DBMS. As can be concluded from the experiments with the realisation functions, the required realisation of geometry requires traverse of all the relational tables, which may result in poor performance of metric analyses for large data sets.

### **7.3.4 Case study: topological structure or geometrical primitives?**

As has already been mentioned a number of times before, it can be expected that spatial queries relying only on topological references perform very well on the topological structure compared to the geometrical primitive, e.g. to find all features that are adjacent to a certain feature. In contrast, the performance of metric and specialisation operations will be slower on the topological structure. These last operations need the coordinates of the objects, which, if performed on the topological structure, will most initiate a join of all the relational tables (dependent on the type of implementation). In [77] it is also concluded that some operations (compute area, distance, etc.) on topological structured data will be slower than on geometrical primitives since it requires querying and joining different relational tables. Another explanation for the better performance of these spatial operations on the geometrical primitives is the internal optimisations provided by the DBMSs and the possibility to apply spatial indexes.

To illustrate the power of topological structure in performing relationship operations,

an experiment was carried out in Oracle Spatial 9i on a data set, which is a selection of the cadastral database of the Netherlands. The test data set contains 1,788,019 parcels and 5,599,089 boundaries. The first query that we use in this experiment is to find all adjacent parcels to the parcel with object identifier 6862 (see figure 7.10). The query was performed on both a topologically structured data set and a geometrically structured data set. The geometries of the parcels were therefore stored explicitly in a table with the geometrical primitive of Oracle Spatial and populated with the `return_polygon` function (section 7.2.2). A spatial index was built on the geometry-column to speed up spatial analyses. The topological structured data set was described in section 7.2.2. Note that performance depends also on spatial clustering, which was not taken into account in this test. For the data set described by geometrical primitives, the query to find all adjacent parcels is given below (using a ‘subselect’ structure), in which the polygons of parcels are stored in the table ‘parcels\_geom’ in the column named ‘shape’. The query finds all parcels that have a ‘touch’ relationship with parcel ‘6862’ using the spatial operator ‘sdo\_relate’ which is implemented on geometrical primitives.

```
SELECT object_id FROM parcels_geom WHERE sdo_relate(shape,(SELECT shape
FROM parcels_geom WHERE object_id=6862), 'MASK=TOUCH, QUERYTYPE=WINDOW') = 'TRUE';
```

The query returned the following result:

```
OBJECT_ID
-----
7142
2067
2066
7141
2065
6862
6861
Elapsed: 00:00:22.05
```

For this query we use Oracle’s spatial operator since spatial operators use the spatial index in contrast to the spatial functions in Oracle (see section 7.3.1). The query plan of the query was checked to verify that the query indeed used the spatial index. As shown in the result, the time needed to perform the geometrical query is about 22 seconds.

In the topologically structured data set, all adjacent parcels to parcel ‘6862’ can be found when all the boundaries are selected which have the specific parcel on the left or right side. The next step is to find the parcel that is located on the other side of the selected boundaries. The result is 0.01 seconds:

```
SELECT l_obj\id, r_obj_id FROM boundary WHERE r_obj_id=6862 OR l_obj_id=6862;
```

```
L_OBJ_ID  R_OBJ_ID
-----  -----
2066      6862
6862      7141
6861      6862
6862      7142
Elapsed: 00:00:00.01
```



Figure 7.10: *Query parcels (6862 and 7142) used in test queries.*

The same test was performed for parcel ‘7142’ (with 28 adjacent parcels). The processing time for this second query was 22.56 seconds for the geometrical query and 00.01 seconds for the topological query. The queries were repeated a number of times which resulted in processing times of the same order, every time. These examples show that this topological query is indeed faster on a topologically structured data set than on the data set described with geometrical primitives.

There is another conclusion that can be drawn from the first query: the results differ.

The topological query does not give parcels ‘2067’ and ‘2065’ as a result since these parcels touch parcel ‘6862’ only at a point and are therefore not seen as adjacent parcels from the topological point of view as defined in the winged edge structure. The result set in spatial analyses using topological structure depends therefore on the topological structure implemented.

The geometrical query does find parcels ‘2067’ (neighbour on the right of parcel ‘2066’) and ‘2065’ as adjacent parcels since they do touch parcel ‘6862’, even if it is at a point. The geometrical query could be further specified by adding the condition that boundaries of two parcels should also overlap (see section 7.3.1). It is a moot point which of these results is ‘correct’. Some applications will require the ‘corner contact’ parcels to be returned as well, and other applications don’t.

## 7.4 Implementation of a 3D geometrical primitive in a DBMS<sup>1</sup>

Present geo-DBMSs do not support 3D geometrical primitives, although 3D objects can be modelled within current techniques as was seen in section 7.1.2. The absence of a real 3D primitive in geo-DBMSs, results in two main problems:

- Geo-DBMSs do not recognise 3D spatial objects, because they do not have a 3D primitive to model the 3D object. This results in DBMS functions not working properly (e.g. there is no validation for the 3D object as a whole and functions

<sup>1</sup>This section is based on [5].

only work with the projection of these objects, because the third dimension is ignored).

- Where 3D objects are stored as one multipolygon or a set of polygons, no relationship exists between the different 2D polygons defining the object. Besides the fact that no validation can be performed and that any set of polygons can be inserted, the main disadvantage is that the same coordinates are listed multiple times (causing risks of inconsistencies) and there is no information about outer or inner boundaries of the polyhedron. Where 2D polygons that bound a 3D object are stored in multiple records, a 1:n relationship exists between the object and the number of records; a more clear and more efficient administration of large data sets requires a 1:1 relationship between objects in reality and objects in the database.

ISO/TC211 spatial schema [87] adopted by OGC defines 3D geometry primitives in an abstract (mathematical) manner. However 3D geometrical primitives are not (yet) included in the OGC Implementation Specification for SQL. In order to fill this gap we worked on a solution in the form of a design and an implementation of a real 3D primitive within a DBMS context. This section presents this solution and describes how 3D spatial objects can be modelled, i.e. stored, validated and queried in a geo-DBMS using a 3D geometrical primitive (also using 3D spatial functions). Many concepts have been developed in the area of 3D modelling [94, 119, 168, 169, 184, 240]. In the research presented here the developed concepts have been translated into a prototype implementation of a true 3D primitive in a DBMS environment. The implementation has been based on a proposal for extending the spatial model of Oracle Spatial 9i with support for a 3D primitive [198].

### 7.4.1 Definition of 3D primitive

There are a number of 3D geometrical primitives possible to model 3D spatial objects:

- **A set of tetrahedra:** This is the simplest 3D primitive and consists of four triangles that form a closed object in 3D coordinate space. The tetrahedron is well defined, because the three points of the four triangles always lie in the same plane. It is relatively easy to create functions that work on this primitive. The disadvantage is that it could take many tetrahedra to construct one factual object; this does not solve the disadvantage of not having a 1:1 relationship between the factual object and the object's representation in the database.
- **Polyhedron:** This is the equivalent of a polygon, but in 3D. It is made up by several flat faces that enclose a volume. An advantage is that one polyhedron equals one factual object. Because a polyhedron can have holes in the exterior and interior boundary, it can model many types of objects. A disadvantage is that the buffer operation results into a non-polyhedral object, because it will contain spherical or cylindrical patches, which cannot be represented by the polyhedron primitive. The solution is to approximate the result of the buffer operation [224].
- **Polyhedron combined with spherical and cylindrical patches:** This is the equivalent of the current 2D geometry data model of most geo-DBMSs

(i.e. straight lines and circular arcs). This solution makes it possible to model 3D objects more realistically (although it is also not closed under the buffer operation). However, modelling with this primitive is complex.

- **CAD objects:** There are many possibilities [120], such as Constructive Solid Geometry, cell decomposition, octree [19] and objects with curved faces. These objects either do not fit with the present OpenGIS/ISO 2D geometry data model or are complex to model without an advanced graphical user interface.

To choose a suitable 3D primitive, a number of criteria were evaluated [2]. The implementation should lead to valid objects. It should be easy to specify instances and to create and enable efficient algorithms. Furthermore, the size and redundancy of storage (conciseness) should be taken in consideration.

The tetrahedron was not selected, because there are several primitives necessary to model one object. CAD objects with curved faces can model a spatial object very realistically, but are complex to model without an advanced graphical user interface and also 2D CAD objects do not (always) fit within the present 2D geometry data model. That leaves the polyhedron option with and without the cylindrical/spherical patches. The one with spherical and cylindrical patches would fit better to the present 2D geometry data model (in which geometry is not only defined by straight lines but also by circular arcs), but ease of creation and implementation favour the polyhedron without spherical and cylindrical patches at first. Therefore, the polyhedron is chosen as the 3D primitive in this research to start with. If needed, spherical and cylindrical patches are approximated by several flat faces. It was also expected that choosing a relatively simple primitive will give more insight into the problems that occur when implementing more complex primitives in the future.

### Implementation

The 3D primitive has been implemented in a geometrical model with internal topology (i.e. topology is maintained within one instance of the object and not between objects). Managing topological structures between objects (e.g. sharing common faces) is not within the scope of the polyhedron primitive. The polyhedron is defined by storing the vertices explicitly (x,y,z) and describing the arrangement of these vertices in the faces of the polyhedron. Internal topology within one object is maintained since only the vertices are stored (no polygons or lines). Faces are defined by internal references to nodes and nodes are shared between faces (figure 7.11). This yields a hierarchical boundary representation [2, 240]. Note that edges are not stored explicitly in this model. The Oracle Spatial geometry type has been extended in order to support the polyhedron primitive. The vertices and arrangement of faces are all stored in the `sdo_ordinate` array.

The interpretation code of the faces (figure 7.11) describes if the list of node references refers to an outer or inner boundary of a polyhedron (face) or if the list of node references refers to an outer or inner ring of a(n outer or inner) face. Most polyhedra will just have an outer boundary, but an inner boundary can for example be used to create a hollow object: the inner boundary will then describe this hollow space. Most faces will just have an outer ring, but inner rings can be used to create cavities in polyhedron. With these elements it is possible to model complex objects, e.g. objects with cavities or objects that are hollow inside. This set of elements is enough for the

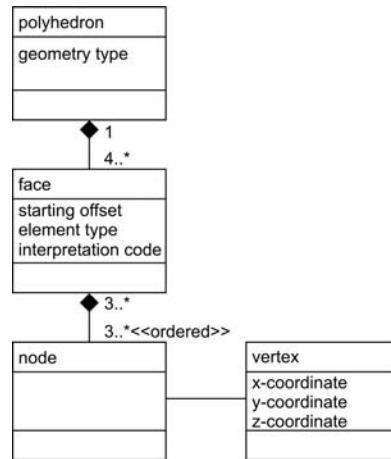

Figure 7.11: UML class diagram describing storage of polyhedron primitive.

implemented functions in the next sections to understand what the 3D spatial objects look like.

In the field of computer graphics (see for example [129]) it is a custom to order all the vertices of outer boundaries (rings) anti-clockwise, seen from the outside of an object, and the vertices of inner boundaries (rings) clockwise. That is, the normal vector of the face points to the outside of the object. This practice is followed in the implementation (details and examples in [4]). A table can now be created to hold polyhedra:

```
CREATE TABLE polyhedron.table (id NUMBER, geometry MDSYS.SDO_GEOMETRY);
```

Then the metadata table can be updated:

```
INSERT INTO user_sdo_geom_metadata VALUES (
  'POLYHEDRON_TABLE', 'GEOMETRY',
  mdsys.sdo_dim_array(
  mdsys.sdo_dim_element('X', -100, 100, 0.001),
  mdsys.sdo_dim_element('Y', -100, 100, 0.001),
  mdsys.sdo_dim_element('Z', -100, 100, 0.001)),
  NULL);
```

To be able to use the 3D R-tree index of Oracle, the polyhedron primitive is defined as an existing sdo\_gtype: '3002'. This corresponds to a fictive 3D polyline going through all the coordinates of the defined polyhedron. When creating a 3D spatial index, a bounding box is created around this line. This bounding box equals the bounding volume around the polyhedron. Oracle Spatial ignores all elements with sdo\_gtype or e-type = 0. If the sdo\_gtype = 0, the object is also ignored by the spatial index. These values are therefore used for the remainder of the elements of the polyhedron (flat faces).

Summarising, the following parameters are used for storing a cube as a polyhedron primitive defined as an extension of the sdo-geometry type:

- `sdo_gtype = 3002` (3D line)
- `sdo_srid = NULL` (no spatial reference system)
- `sdo_point = NULL` (no point data)
- `sdo_elem_info = 1,2,1` (line consisting of straight segments), and `x,0,1006` (6 times an exterior polyhedron boundary, `x` is the starting offset in the array with ordinates)
- `sdo_ordinates`: contains eight coordinate triplets and six face descriptions

The query to insert a cube in the table, is:

```
INSERT INTO polyhedron_table (id, geometry) VALUES (1,
mdsys.sdo_geometry(3002, -- geometry type: 3D polyline
NULL, NULL,
mdsys.sdo_elem_info_array(1,2,1, 25,0,1006, 29,0,1006, 33,0,1006, 37,0,1006,
41,0,1006, 45,0,1006),
-- starting offset, e_type, interpretation code,
-- first triplet is fictive polyline, followed by 6 faces
mdsys.sdo_ordinate_array(
1,1,0, 1,3,0, 3,3,0, 3,1,0, -- vertices
1,1,2, 1,3,2, 3,3,2, 3,1,2,
-- bottom, top, front face, defined by references to nodes:
1,2,3,4, 8,7,6,5, 1,4,8,5,
-- back, left, right face, defined by references to nodes:
2,6,7,3, 1,5,6,2, 4,3,7,8
)));
```

Note that in a full implementation of the 3D primitive (that starts from scratch) two arrays would be used: one for the coordinates and one for the references. However, since the `sdo_geometry` framework was used, both arrays were combined in the `sdo_ordinate` array. A 3D R-tree index can be created by the following SQL-statement:

```
CREATE INDEX polyhedron_table_index ON polyhedron_table(geometry)
INDEXTYPE IS mdsys.spatial_index parameters('sdo_indx_dims=3');
```

## 7.4.2 Validation

It is important that the spatial data is checked (validated) when it is inserted in the DBMS or when it is updated. Valid objects are necessary to make sure that the objects can be manipulated in a correct way, e.g. it is impossible to compute the volume of a cube when the top face is omitted; this would be an open box without a volume. Validating may seem quite easy for humans, but a computer needs an explicit set of rules to check the spatial data. To allow for checking the spatial data, it is important to give an accurate definition of the 3D primitive. In [2] definitions of both a polyhedron and a pseudo-polyhedron are given:

- **Polyhedron:** A polyhedron (figure 7.12 (a)) is a bounded subset of 3D coordinate space enclosed by a finite set of flat polygons such that every edge of a polygon is shared by exactly one other polygon (adjacent polygons). The vertices and edges of the polygons are the vertices and edges of the polyhedron; the polygons are the faces of the polyhedron. The edges and faces are two-manifold (see below).



- **Pseudo-polyhedron:** A pseudo-polyhedron (figure 7.12 (b)) is a bounded subset of 3D coordinate space enclosed by a finite set of planar faces such that (a) every edge has at least two adjacent faces, and (b) if any two faces meet, they meet at an edge.

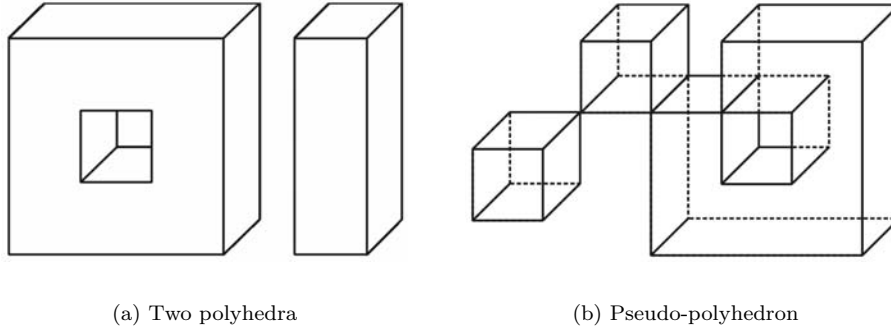

Figure 7.12: *Examples of polyhedra.*

Polyhedra are therefore, a subset of pseudo-polyhedra. Edges and vertices, as boundary elements for polyhedra and pseudo-polyhedra, may be either two-manifold (in case of polyhedra) or non-manifold (in case of pseudo-polyhedra) elements.

In the case of edges, they are two(non)-manifold elements when every point of it is also a two(non)-manifold point, except that either or both of its ending vertices might be a point of the opposite type. A two-manifold edge is adjacent to exactly two faces, and a two-manifold vertex is the apex of only one cone of faces.

In our implementation we used the definition of a polyhedron of [2], which is a two-manifold element. Consequently, a valid polyhedron bounds a single volume, which means that from every point (also on the boundary), every other point (also on the boundary) can be reached via the interior. Based on this definition, a validation function has been implemented.

### Tolerance

The validation function and some of the 3D functions have a tolerance value as input parameter. The points that make up the polygon can be slightly out of the flat plane, because of the geodetic measuring methods [210] and the finite representation of coordinates in a digital computer. To solve this problem a tolerance value has been introduced. The faces of a polyhedron are flat within this tolerance. This tolerance value should not be too large, otherwise invalid objects will be accepted as valid. A good value for the tolerance is the standard deviation of the geodetic measurements.

### Implementation

The definition of the polyhedron primitive is the basis for a set of validation rules that have been implemented to evaluate the validity of stored objects. All the rules together enforce the correctness of the stored polyhedra. According to the implemented validation rules, a polyhedron is valid when (see below):

- it has been stored correctly;
- it has flat faces;
- it is two-manifold (it bounds a single volume);
- its faces are simplic;
- it is orientable.

**Correct storage** First of all, a check is needed on the storage of the data. It is important for the validation function to work properly that the spatial objects are stored as described in section 7.4.1. This means that valid interpretation codes need to be used and that node references in the faces should correspond with an existing vertex. If the spatial object is correctly stored the next test can be carried out.

**Flatness characteristics** The next test evaluates the flatness of the faces. At the same time it is tested if an inner boundary of a face is in the same plane as its corresponding outer boundary. All faces should be flat within a given tolerance. This is tested by estimating a least squares plane through the average coordinate of all vertices:

$$x_c = \frac{1}{n} \sum_{i=1}^n x_i \quad y_c = \frac{1}{n} \sum_{i=1}^n y_i \quad z_c = \frac{1}{n} \sum_{i=1}^n z_i$$

A least squares plane minimises:

$$\sum_{i=1}^n (Ax_i + By_i + Cz_i - D)^2$$

where A, B and C are the components of the normal vector, D is the distance to the origin,  $x_i, y_i$  and  $z_i$  are the vertices and n is the number of vertices. If the average coordinate is subtracted from the vertices, the plane goes through the origin, which results in D=0. The components of the normal vector are now the unknowns and the equations can be solved. To retrieve the plane equation, D can be computed by:

$$Ax_c + By_c + Cz_c + D = 0$$

where  $x_c, y_c$  and  $z_c$  are the average coordinates of all vertices. The derived plane equation is used to compute the distance from each vertex to this least squares plane. If all distances are smaller than the tolerance value, the face is planar.

**Two-manifold characteristics** The next step is to test if the polyhedron bounds a single volume in 3D space (two-manifold polyhedron). To test if a polyhedron is a two-manifold polyhedron, a set of rules has been set up and implemented to enforce the two-manifold characteristic of a polyhedron:

- All edges (defined by two vertices) occur exactly twice in opposite order.
- Inner or outer faces should not intersect (touch is allowed).
- A polyhedron can only contain one connected volume containing one or more holes.
- Vertices related to one shell-structure should be two-manifold.

**Simplicity characteristics** The faces should be simplic. Therefore a test was implemented to check that faces have an area, they are not self-intersecting and they are not built of disconnected parts. Also an inner boundary of a face should not intersect (touch is allowed) with its outer boundary.

**Orientation characteristics** The final test of the validation is to check if the vertices in the faces are orientated correctly, i.e. anti-clockwise (looking from the outside) for outer boundaries and clockwise for inner boundaries. Only one face of the polyhedron has to be tested, because if the edges are two-manifold, the whole object is either orientated correctly or incorrectly. It is important which face to test. From the bottom face we know that the normal vector should be pointing towards the negative z-direction. The cross product of two following edges of a convex part of this bottom face gives the normal vector. The z-component of this normal vector should be negative [210].

If all the criteria in the validation are met, then the spatial object is valid. The following SQL-statement tries to validate the two objects shown in figure 7.13. How the validation function has been implemented is described in section 7.4.4.

```
SELECT validate\_polyhedron(geom,0.05) VALID FROM table;
```

```
VALID
```

```
-----  
Not a 2-manifold object  
Not a 2-manifold object
```

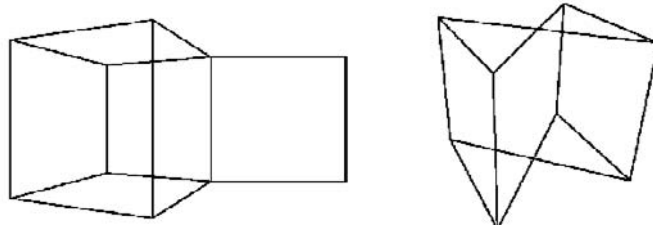

Figure 7.13: *Invalid objects, because of dangling face (left) and intersecting faces (right).*

Both objects are detected to be invalid within a tolerance value of 0.05. Note that the coordinates of these objects are measured in metres. A tolerance value of 0.05 then corresponds to a maximum error of 5 centimetres.

### Critical objects

The statement that 3D data structures are very complex compared to 2D data structures and that therefore a correct and finite definition of a polyhedron is not easy to give, is underlined by the fact that still some valid polyhedra are determined as invalid by our validation test. The definitions above exclude the valid polyhedron as shown in figure 7.14 (a), which is a cube with a triangle-shaped hole which touches the upper face. The upper face is divided into two parts, by which the middle-edge

of this face occurs four times in the definition of the polyhedron. According to the definition (and our implementation) this polyhedron is not valid, since the edge in the upper face is used more than twice. However, in this case this does not cause division of the polyhedron into disconnected parts. Therefore this polyhedron should have been determined as valid. If the same polyhedron is modelled by not dividing the upper-face and only defining a hole (that touches the upper-face), the object is determined as valid.

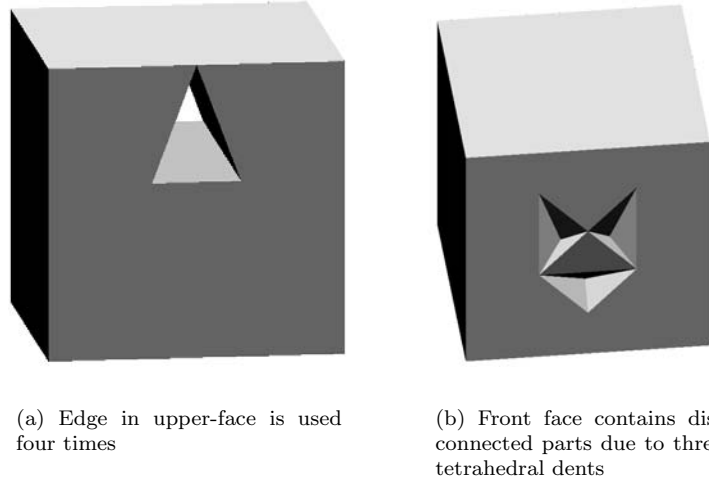

Figure 7.14: *Valid polyhedra which are determined as invalid by the implementation.*

Another valid polyhedron, which is not valid according to the implemented rules, is shown in figure 7.14 (b). This is a polyhedron with three pyramid-shaped dents in the front face, by which the front face contains disconnected parts. The front face is not simplicial, since the inner rings of the face divide the face into disconnected parts. However, since the face does not divide the polyhedron into disconnected parts, the polyhedron should have been determined as valid.

### 7.4.3 Spatial indexing in 3D

Oracle Spatial 9i supports R-trees [68] up to four dimensions and the (2D) quadtree (no support for octree). Therefore the Oracle R-tree indexing can be used for the 3D primitive. Using the Oracle spatial index is made possible by storing the 3D objects in a special way, as was mentioned before. A 3D polyline going through all the coordinates of the defined polyhedron can be imagined. When creating a 3D R-tree in Oracle, a bounding volume is created around this line, which equals the bounding volume around the polyhedron.

#### 2D or 3D spatial index?

In many spatial applications the extent of the domain in the x,y plane is larger than

in the z-direction. For example, a city plan typically covers an area of five by five kilometres with buildings up to 50 meters tall. This, plus the fact that queries usually try to find all the objects in a specific x,y region (with possibly objects that are on top of each other), may make a 3D spatial index hardly any more useful than a 2D index (on x,y coordinates only). In these kinds of queries the x- and y-coordinates are more selective than the z-coordinates. This means a 2D spatial index might work just as well as or better than a 3D spatial index.

A test was executed to see if one might just as well use a 2D spatial index instead of a 3D spatial index [4]. The test data set consisted of 1348 3D objects that are stored with the 3D primitive. In the test (retrieving 3D objects that intersect with a 3D box) the efficiency of the spatial index was measured by determining the number of candidates that were selected by the spatial index compared to the actual number of intersections. `Sdo_filter` is the Oracle Spatial function that uses the spatial index to select candidates for spatial queries. It is the only Oracle Spatial function that works in 3D (in connection with the 3D R-tree).

The following SQL-statement shows how to use this filter to retrieve the number of candidates:

```
SELECT COUNT(id) FROM buildings_table WHERE SDO_FILTER(geometry,
(SELECT geometry FROM querywindow WHERE id=1), 'querytype = WINDOW')='TRUE';
```

To retrieve the number of actual intersections, a 3D Boolean intersection function is used that also was implemented (see section 7.4.4). The function can be used in an SQL-statement as follows:

```
SELECT COUNT(id) FROM buildings_table WHERE intersection(geometry,
(SELECT geometry FROM querywindow WHERE id=1), 0.05)=1;
```

To use the spatial index in the implemented function, the spatial filter has to be combined with the intersection function like this:

```
SELECT COUNT(id) FROM buildings_table WHERE SDO_FILTER(geometry,
(SELECT geometry FROM querywindow WHERE id=1), 'querytype = WINDOW')='TRUE'
AND
INTERSECTION(geometry, (SELECT geometry FROM querywindow WHERE id=1), 0.05)=1;
```

From the results of the test it can be concluded that a 2D index works as good as a 3D spatial index when the query window contains the ground level [4]:

Query box	Result	No spatial index		2D R-tree		3D R-tree	
		# cand.	eff.	# cand.	eff.	# cand.	eff.
0-50m	509	1348	37.76%	510	99.80%	510	99.80%
20-50m	59	1348	0.04%	510	11.57%	59	100%

However, if the ground level is not included in a 3D query window then the 3D R-tree is significantly faster (more efficient), because most objects can be skipped.

With the knowledge that the overhead of a 2D R-tree and a 3D R-tree are both relatively small, there may be no reason to build a 2D R-tree on the data set instead

of a 3D R-tree. The 3D R-tree performs equally well as the 2D R-tree when the query window contains the ground level height, but it performs a lot better when this query window does not contain the ground level height.

#### 7.4.4 3D functions

As was mentioned in section 7.3.2, the standard functions in Oracle, just as in most geo-DBMSs, only work with the projection of 3D spatial objects onto 2D coordinate space, because the third dimension is ignored. To offer realistic functionality, some of the most common functions have been implemented in 3D (for 0D up to 3D primitives):

- function to insert data: creating data from 3D multipolygons and VRML;
- function to validate polyhedron: validation function;
- functions that return a Boolean: point-in-polyhedron query and intersection test (polyhedron-polyhedron);
- unary functions that return a scalar: area, perimeter and volume;
- binary functions that return a scalar: distance between centroids;
- unary functions that return a simple geometry: bounding box, centroid, 2D footprint and transformation functions;
- binary functions that return a simple geometry: line segment representing the distance between centroids.

Functions that return a complex geometry such as tetrahedrisation and skeletonisation are not implemented yet, but are also interesting, because of their analogy with 2D triangulation and generalisation. The functions are implemented in Java which has the advantage that the functions are available outside Oracle as well (though implementation in PL/SQL would probably show better performance).

It is clear that functions in 3D require more complex algorithms than 2D functions. This also has a big influence on the computational complexity. To maintain good performance, the algorithms have been implemented as efficiently as possible. Spatial data sets can contain many objects, so a slightly more efficient algorithm already will yield noticeable better performance when querying all these objects.

The next example shows how to compute the area, volume and perimeter (length of edges) of the objects in figure 7.15. The figure shows a tetrahedron (1), a cube (2), a cube with a dent in one of the faces (3), a hollow cube (4) and a cube with hole that runs through the whole cube (5).

```
SELECT id, area3d(geom), volume(geom), perimeter(geom) FROM testobjects;
```

ID	AREA3D(GEOM)	VOLUME(GEOM)	PERIMETER(GEOM)
1	22.9530689	5.5	22.0723224
2	54	27	36
3	58	26	48
4	204	98	96
5	64	24	56

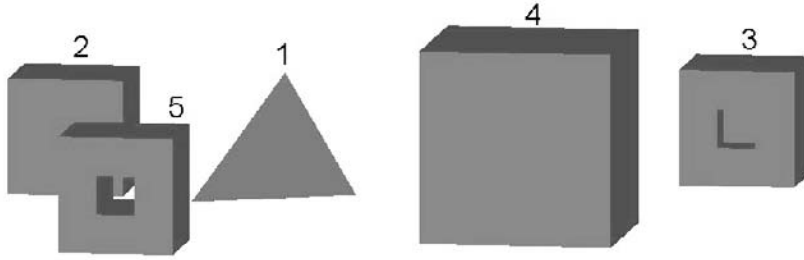

Figure 7.15: Set of five polyhedra used to show some 3D unary functions. Note that object 4 is hollow.

## 7.5 Conclusions

This chapter showed that DBMSs are getting increasingly mature in maintenance of spatial objects.

### Geometrical primitive in DBMSs

Mainstream and popular non-commercial DBMSs offer support, maintenance and some operations that allow spatial analysis of objects defined in geometrical primitives. However, the implementation of geometrical primitives is still not complete. Real 3D volumetric data types are lacking. A solution for 3D representation in the DBMS was designed as part of this thesis and described in this chapter. The implemented geometrical primitive (polyhedron without spherical and cylindrical patches) showed that it is possible to support a true 3D primitive in the DBMS (including validation functions and geometrical functions in 3D) although the 3D primitive needs further development to be able to model more complex geometries.

### Topological structure in DBMSs

Support for topological structure management is a relatively new issue in DBMSs (recently available in Laser-Scan Radius Topology and Oracle Spatial 10g). The lack of topological structure has led to a variety of topological structures in front-end applications missing uniformity as a result. Managing topology in front-ends undermines data consistency and integrity at DBMS level. In addition, the conversion between the stored geometry in DBMS and the application dependent topological layer has its influence on performance. An issue which needs attention is the type of topology and dimensionality of the models. Current efforts are towards providing 2D topological structure (planar partition, linear networks) that most probably will restrict the topological operators to 2D. Maintenance of several different types of topological structures appears unavoidable.

In this chapter two user-defined implementations of a topological structure in a DBMS were described: one in 2D (winged edge) and one in 3D (Simplified Spatial Model). The experiments with these structures, including realisation functions, show potentials. However, at the moment user-defined solutions of topological structure focus on organisation of data. The consistency checks and updates still need to be performed outside the DBMS. Also performance of metrical operations on the topological struc-

ture might become critical in case of large data sets. A commercial solution of a 2D topological structure in the DBMS was described in this chapter (i.e. Radius Topology).

### **Topological structure or geometrical primitive in DBMSs**

Geometrical primitives are already supported by DBMS and, as first implemented, are considered as a basic model. However, to improve data quality and data consistency topological structure offers better possibilities. As was illustrated in the example (section 7.3.4), spatial queries only relying on topological references perform well in the topological structure compared to topological analyses on geometrical primitives. On the other hand, experiments with Radius Topology 1.0 with large-scale spatial data [108] showed that storage requirements and performance of the plain geometry approach are (still) superior in many cases. At the moment topological structure is therefore mainly appropriate for representing relationship operations and for checking the quality of data during updates.

To make geometrical analyses on topologically structured data possible a function is needed to derive the geometry from the topology. On the other hand, for full support of topology in DBMSs, a function to derive the topology from geometry is also needed. Many spatial operations give geometries as a result and it should be possible to convert these geometries into topological layers in order to get a topologically structured data set (also in case of topological results with redundant information such a function is needed). Consequently geometry based operators will always be necessary to build the topology: to find all the topological relationships in a new layer, functions based on geometrical primitives are required.

### **Spatial functions in DBMS or in front-ends**

DBMS plays an important role in the new generation GIS architecture. Mainstream DBMSs have implemented support for spatial data types and they are still improving support for geometrical primitives and topological structures. Does it mean that a DBMS will and should include all spatial analyses, including complex spatial analyses which have been optimised in GISs during decades? Does it mean that traditional GIS software (or extended with attribute maintenance CAD software) has to convert to a tool for import, visualisation, editing and exploration of spatial data?

Many spatial functionalities are (and probably will be) available only at the front-end and not at DBMS level (e.g. spatial analyses which are specific for certain domains and applications, tools for inserting new data, interaction tools for starting spatial analyses, visualisation tools). Also, too many operations performed at a DBMS level may lead to overloading of the server and affecting the performance of the DBMS. On the other hand, too few operations provided by DBMS will result in development of many functionalities by the front-end, i.e. duplication of development efforts and resources. The question now is: which spatial operations should DBMSs take over?

The balance depends very much on the scope and constraints of spatial analysis: what is spatial analysis and what is spatial analysis in a DBMS context. DBMSs are essential in applications in which large amounts of large-scale geo-data in vector-format need to be maintained and managed, such as cadastral data, or spatial data used in municipalities. In principal, generic spatial functionalities that are not specific to a certain application belong in the DBMS and not in front-end applications. Examples



are the spatial functions which examine the topological relationships between spatial objects. Arguments for this are logical consistency of the data, better performance and better maintenance of the quality of the data. Unnecessary transport and conversions of data between DBMSs and GIS front-ends prone to errors can be avoided. In contrast to the group of selection operations, specialisation and navigation in the spatial domain can be very complex and time consuming. If they are performed at a DBMS level (on the server), the performance can decrease drastically. Furthermore, such complex operations may not be needed for all kind of applications. Therefore, complex operations falling in the group of specialisation and navigation operations can be considered to be left for implementation by the front-end.

A relevant question in this whole discussion is whether spatial functionalities implemented in the DBMS will replace spatial functions that were originally built in GISs. GIS has become an important instrument in workprocesses of companies and governmental offices. A lot of money and effort have been invested by GIS vendors for selling their software and for giving support and by organisations to develop specific GIS applications. Future will prove if GIS vendors are willing to give up spatial analyses (which always have been an important part of GISs) by which GISs will be converted into visualisation/interaction tools (including editing) built on top of geo-DBMSs and if organisations will move from spatial analyses in GIS applications to spatial analyses in DBMSs.



## Chapter 8

# 3D GIS and accessing a 3D geo-DBMS with front-ends

In chapter 7 the possibilities to maintain and analyse 2D and 3D spatial objects in a geo-DBMS were described. A geo-DBMS is part of the new generation GIS architecture as was seen in section 6.6. For this research on 3D cadastre other 3D aspects of GIS than geo-DBMS functionality are also important. The implementation of a 3D cadastre addresses the issues of inserting, maintaining, querying, editing and visualising 3D geo-objects in general. These are core topics of 3D GIS. Therefore the state-of-the-art of 3D GIS will be described in section 8.1.

Once 3D spatial objects have been stored in a DBMS, these objects can be optimally maintained, together with 2D spatial objects and non-spatial objects, in an integrated DBMS environment. In (object) relational DBMSs, geo-information can only be accessed with SQL commands of which the output is a sequence of characters and numbers (or binary output). In order to query and edit the spatial objects in a visual environment, spatial information maintained in DBMSs should be accessible in front-ends having visualisation utilities.

The aim of second part of this chapter is to show the state-of-the-art of technology to access spatial objects, and 3D spatial objects in particular, which are stored in a DBMS with different front-ends.

In this chapter three front-ends are examined to access 2D and 3D spatial information organised in the geometrical model of Oracle: a CAD-oriented system (section 8.2), a GIS (section 8.3) and a self-developed Web based front-end (section 8.4).

The chapter ends with concluding remarks.

## 8.1 3D GIS<sup>1</sup>

2D GIS analysis has shown its limitations in certain applications as was seen in section 5.5. Therefore the need for 3D geo-information is rapidly increasing.

Developments in the area of 3D GIS are motivated by a growing need for 3D information from one side and new technologies on the other side, e.g. improving techniques of 3D data collection, of 3D object reconstruction but also of computer hardware. Processors, memory and disk space devices have become more efficient in processing large data sets (especially graphical cards also used by the games industry). Furthermore elaborated tools to display and interact with 3D data are evolving.

This section gives an extensive overview on the status of 3D GIS by considering the core topics of 3D GIS:

- organisation of 3D data (section 8.1.1);
- 3D data collection and object reconstruction (section 8.1.2);
- visualisation and navigation in 3D environments (section 8.1.3);
- 3D analysing and 3D editing (see section 8.1.4).

### 8.1.1 Organisation of 3D data

#### 3D representations

Several approaches may appear very appropriate for 3D GIS models: Constructive Solid Geometry (CSG), voxel representation (regular space subdivision), irregular space subdivision (Tetrahedron Networks) and boundary representation. All approaches show advantages and disadvantages considering different criteria and depending on the specific application. The advantage of CSG is that it is very appropriate for computer-aided manufacturing: a brick with a hole drilled through is represented as “just that”. The disadvantage for real world modelling is that the objects and their relationships might become very complex. Voxels are appropriate in modelling continuous phenomena such as geology, soil, etc. Voxels are regular in modelling: the basic unit of the model is the same. A disadvantage of voxels is that high-resolution data requires large volume of computer space. Another disadvantage is that surface is not regular by nature: it is always somehow “rough”. The tetrahedron object is well defined, because the three points of each triangle always lie in the same plane [20, 220]. A disadvantage is that it could take many tetrahedra to construct one factual object. The main advantage of boundary representation is that it is optimal for representing real-world objects. The boundary of real-world objects can be observed, measured and surveyed from properties that are visible (i.e. ‘boundaries’). Furthermore most of the rendering engines are based on boundary representations (i.e. triangles). Unfortunately, boundary representations are not unique and constraints (rules for modelling) may get very complex to implement (e.g. how to determine neighbours in 3D, how to ensure planarity of faces in 3D, etc.).

#### Logical models of 3D data

DBMS vendors still have not made the step to implement 3D data types in their

---

<sup>1</sup>This section is based on [204].

geometrical model as was seen in chapter 7. Reasons for this may be that the OpenGIS Consortium (OGC) is still working on extension of the Simple Feature Specification to support 3D features and consensus on a 3D topological structure has not yet been achieved. Another limiting factor is the relatively low (but growing) market demand for 3D support in DBMS. The new generation GIS architecture for 3D is not (yet) adopted by GIS-users. The current trend is to develop specific ad hoc solutions when using 3D geo-information instead of building a database for maintaining spatial objects. User-defined implementations of 3D GIS models can be found in [19, 147, 181, 227].

At present, 3D implementations defined by ISO/TC 211 and OGC are focused on boundary representation. However CSG may appear appropriate for designed large-scale real-world objects (trees, traffic signs, building ornaments, statues) and voxel representation for continuous phenomena.

### 8.1.2 3D data collection and object reconstruction

3D GIS requires 3D representations of distinct objects. Traditionally, (2D) GIS makes use of data collection techniques such as surveying and measurements of the real world, while creating 3D models used to be done separately from GIS, either using CAD software or photogrammetric methods and modelling software. This subsection describes if and how CAD designs and 3D object reconstruction techniques can be used for 3D GIS models.

#### GIS and CAD

In the late 80s and early 90s many publications were written on GIS versus CAD and how GIS and CAD could be effectively combined [32, 75, 106, 125, 187]. The tendency of these papers is 'how to use CAD systems for certain GIS-tasks'. The typical tasks range from geographic data entry to automated map production (including some cartographic aspects). This was motivated by the fact that two decades ago, CAD systems were more general available than GISs. However, one could hardly observe the desire for true integration of the different data models and functionalities offered by CAD and GIS. About a decade ago the attention indeed shifted to the integration of CAD and GIS functionality driven by application domains such as urban and landscape architecture and planning [79, 121, 185, 193, 206]. The presented solutions are often of a very ad hoc nature (capturing and transferring simple 3D models between the different systems) or require custom-made software solutions. Often these papers end with the remark that the off-the-shelf CAD/GIS functionality still needs to be integrated for better support of their applications. However, seldom a clue is given how this could be achieved or what could be the fundamental issue causing the integration problems. More recent sources seem to be commercial and/or development notices such as [111], where the emphasis is on providing data exchange mechanisms either through shared files, translators, or inter-API's, but till now, there has been little care for the fundamental issues that need to be addressed, such as integrated geometrical data structures concerning 3D and topological support (see [100] for an overview), harmonised semantics of the concepts used and integrated data management (in contrast to independent and inconsistent information islands with data conversions and transfer) [143]. The issue of a fundamental integration of

GIS and CAD will be further discussed in section 11.2.4.

### Object reconstruction

In the last several years a lot of research is conducted towards automation of 3D object reconstruction (especially man-made objects). There is a variety of approaches based on different data sources and aiming at different resolution and accuracy. For constructing 3D models, four general approaches can be considered:

- **Bottom-up:** using footprints (from existing 2D maps) and extrude the footprints with a given height using laserscan data, surveying, GPS or photogrammetric data. The problem with this approach is that the detail of roofs cannot be modelled. Since one value is used for every footprint, the buildings appear as blocks in the model. The approach however is very fast and sufficient for applications that do not need high accuracy (do not need roofs) and many details.
- **Top-down:** using the roof obtained from aerial stereo-photographs, airborne laserscan data and some height information from the ground (one or more height points near the buildings, DTMs). These approaches emphasise the modelling of roofs [11, 67]. Obviously the accuracy of the obtained 3D models are dependent on the resolution of the source data.
- **Detailed reconstructing of all details:** the most common approach is to fit predefined shapes (building primitives) to the 3D point clouds obtained from laserscan data [222] or 3D edges extracted from aerial photographs [59, 109]. The advantage of this approach is the full automation and the major disadvantage is that it is very time-consuming since the algorithms used are very complex.
- **Combination of all of them:** e.g. laserscan data and topographic data [78], aerial photographs and maps [69, 207] etc. This approach contains some risks since many data sources are used and combined, all with different scale and quality. Using only few data sources will introduce fewer inconsistencies to be solved during processing.

There is not a universal automatic 3D data reconstruction approach. At the moment, the manual approach is still needed to reconstruct large-scale detailed 3D models, which is a bottleneck for modelling urban areas in 3D. More research is needed to make the process of 3D reconstruction (semi)automatic. A tighter connection between 3D object reconstruction and GIS will support developments in 3D GIS.

Important for 3D object reconstruction is to derive terrain elevation itself (Digital Terrain Models and Digital Elevation Models). Laser altimetry can be used to automatically derive terrain and elevation models with high accuracy, e.g. the AHN (*Actueel Hoogtebestand Nederland*), which is a DTM covering the whole area of the Netherlands with a density of one point per 16 square meters and in forest areas a density of 36 square meters (see chapter 9).

### 8.1.3 Visualisation and navigation in 3D environments

3D models usual deal with large data sets, requiring efficient hardware and software for visualisation. Several techniques are being developed to improve efficiency of navigating through a 3D model, such as different levels of detail [94, 162], low-resolution

graphics and imposters (image of object instead of geometry of object) [163]. All these techniques aim at visualising high detail when objects are close by and low detail when objects are further away. Different representations of objects can be either stored in the DBMS or created on-the-fly. The main problems of storing multirepresentations are fitting high detailed data to data that is represented at a low level of detail and the redundant storage of representations.

A specific problem that comes with visualising 3D geo-data compared to 2D geo-data is readability of the data (approaching realism). To make a view realistic one can add illumination, shade, fog, textures, shadow, and material to the geometry (apart from traditional characteristics such as colour). Apart from visualising 3D models, interacting in 3D environments (exploring 3D models) also requires specific techniques. These issues touch the fundamental difference between the Digital Landscape Model (DLM) and the Digital Cartographic Model (DCM) which is a well-known issue in traditional map production. The stored data set of a specific study area is called the Digital Landscape Model. This model has to be converted into a Digital Cartographic Model to make the (spatial) data set suitable for communication to other persons. The DCM consists of series of instructions to the plotter, printer, screen, etc. to produce dots, dashes or patches, in different sizes, colours and textures to make the content of the data set readable [95]. In 3D this means that apart from spatial and non-spatial information of spatial objects (DLM) also characteristics for visualising and interacting with the objects (DCM) need to be maintained. Although visualising in 2D also requires organising cartographic aspects apart from the content of the data, the DCM aspects to be considered in 3D are much more, such as physical properties of objects (texture and material), behaviour (e.g. on-click-open) and different levels of detail representations. This requires several new elements to be organised in the database compared to 2D data.

#### **Virtual reality and augmented reality**

Virtual Reality (VR) and Augmented Reality (AR) are supporting techniques for improving visualisations of and interaction with 3D geo-data [219], e.g. putting textures on objects and facilitating navigation through the 3D environment [66]. VR is a realistic representation of data (2D, 2.5D and 3D), which means that details and physical properties are represented highly realistically even together with sounds and behaviours of the objects. Manipulation and interaction in the views can take place by mouse click, animations, navigation and exploration. In AR a user explores and navigates in the real world augmented by computer generated data. Several researches have already addressed the issue to link 3D GIS with VR, e.g. [219].

All kinds of devices are nowadays available to support visualisation in VR/AR environments [241], such as elaborated 3D display (Head Mounted Device, workbench, panorama, CAVE, Cockpit), wire and wireless devices for positioning (gyros, accelerators, GPS, GSM, WLAN), sensor devices to track the movements of the user (Power Glove, indoor outdoor tracking systems) and various acceleration hardware (see figure 8.1).

#### **3D GIS and Internet**

3D Web visualisation is also progressing. The research on spatial querying and 3D visualisation using VRML (Virtual Reality Modelling Language), X3D (eXtensible 3D) and/or GML (Geographic Markup Language) has resulted in several prototype

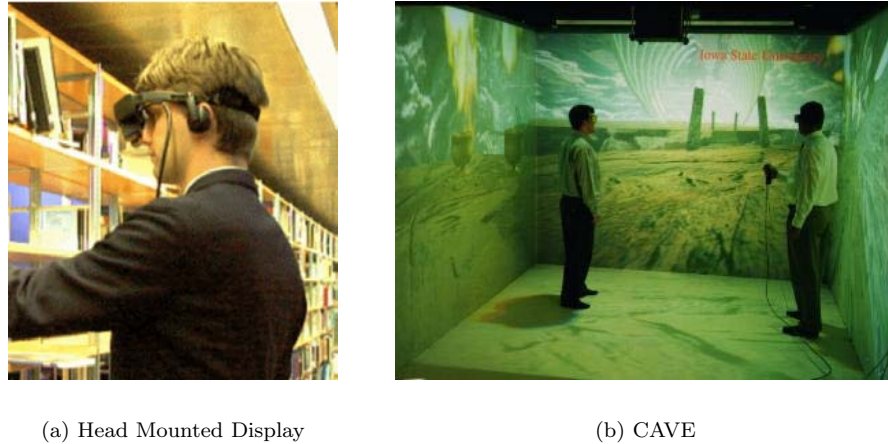

Figure 8.1: *Examples of new devices to support visualisation in VR/AR environments.*

systems [13, 31, 35, 96, 104, 240]. Although research on spatial querying and visualisation of geo-objects organised in a DBMS using Web based techniques is not (yet) available (see section 8.4).

#### 8.1.4 3D analyses and 3D editing

GIS software-tools have also made a significant movement towards 3D GIS. In [242] a survey on mainstream GIS software is presented including: ArcScene [51], Imagine VirtualGIS [50], PAMAP GIS Topographer [165] and GeoMedia Terrain [85]. In [242] it is concluded that major progress in 3D GIS has been made on improving 3D visualisation and animation. However, 3D functionality is still lacking such as generating and editing 3D geo-objects, 3D structuring, 3D manipulation and 3D analyses (3D overlay, 3D buffering, 3D shortest route on polyhedral or TIN surface). An example of the implementation of a specific 3D analysis, 3D buffering, is described in [224]. Concerning editing of 3D geo-data in the new generation GIS architecture, CAD and GIS front-ends should be able to read 3D output and write it to both topological and geometrical structures in DBMSs in which the front-end has to be able to preserve the topology of the 3D object. This topic has not yet been addressed in previous research.

## 8.2 Accessing a geo-DBMS with a CAD front-end

This section describes how to access spatial objects that are stored in Oracle Spatial using a CAD oriented front-end. Bentley's MicroStation GeoGraphics [10] is an extension of the CAD software MicroStation containing functions specific for geo-information and for connection to Oracle Spatial. The organisation of data within



MicroStation GeoGraphics (MS GG) is defined in a project hierarchical structure. Project represents the data for the entire study area. The second level is the category, which groups features with a similar theme (e.g. buildings, rivers). One project can have many categories but a category may belong to only one project. Feature is at the third level and represents one or more spatial objects with the same thematic attributes (e.g. the bank building, the school building). A category may have many features but a feature may belong to only one category. Feature is the basic structural unit in MS GG.

With MS GG there are two tools delivered to query and post data from Oracle Spatial: a MS GG tool and a Java applet “Spatial Viewer”. Here we focus on the MS GG tool. The Spatial Viewer is described at the end of this section.

Visualisation of spatial data from Oracle Spatial 9i using the MS GG tool is relatively simple and straightforward. The user has to create a project and connect to Oracle Spatial. MS GG checks the Oracle metadata table for the name of the table(s) and corresponding columns that contain spatial data. These are supplied to the user for display. In this case, the geometries will be visualised, but will not be available for querying and editing. More steps have to be taken in order to distinguish between different spatial objects stored in Oracle Spatial (e.g. ‘identify’ or ‘query’) and also in order to edit objects maintained in Oracle Spatial. In general, each spatial object in the Oracle database has to be assigned to a predefined feature in MS GG, but depending on the original source of the data (Oracle or MS GG), different steps have to be followed. We completed a number of case studies with MS GG (version 8.1.0.7) following the two different approaches of representing 3D objects (as a set of 3D polygons and as a multipolygon defined in 3D), having the data initially organised either in Oracle (user-defined tables) or in MicroStation (graphics in a design file) (see also [242]).

#### **Geometrical data initially organised in Oracle Spatial 9i**

The required steps to assess and query the objects that are originally organised in Oracle Spatial 9i are [242]:

- Create semantics, i.e. project (by specifying the Oracle connection and the Oracle database), categories and features. This step is enough for only visualising spatial layers from Oracle Spatial.
- Register the spatial table, stored in Oracle Spatial as MS GG layer by creating a new MS GG layer and referencing this new layer to the corresponding Oracle table and column that contains the geometries.
- Link features (the code of the feature) to the corresponding spatial objects (id of spatial object). Running an appropriate script within Oracle is one of the easiest ways to complete this operation in case of many objects. Both the features and spatial objects are maintained in the DBMS.

To illustrate the steps to visualise and query spatial objects maintained in Oracle Spatial with the MS GG tool, we use a table with buildings, represented as a set of faces (3D polygons). The data set with buildings is organised in a relational table (BODY) that originally consisted of only three columns (BODY\_ID, FACE\_ID and SHAPE). The column SHAPE contains the geometries of the objects as mdsys.sdo\_geometry type, i.e. the polygons. The links between FACE\_ID and SHAPE is 1:1 and the link

between `FACE_ID` and `BODY_ID` is m:1.

**1. Creating project, category and features** Bearing in mind the basic conceptual structure of MS GG we created a project (cadastre), a category (buildings) and several features (build1, build2, build3 and build4) in MS GG. The four buildings (polyhedrons) are instances of the type (category) buildings. This operation resulted in twelve new relational tables in Oracle Spatial. The names of the tables created by MS GG and us (in bold) are: **BODY**, **CATEGORY**, **FEATURE**, **MAPS**, **MSCATALOG**, **UGCATEGORY**, **UGCOMMAND**, **UGFEATURE**, **UGJOIN\_CAT**, **UGLAYER**, **UGMAP**, **UGMAPINDEX** and **UGTABLE\_CAT**. ‘UG’ refers to MicroStation GeoGraphics. Among all these tables, **MSCATALOG** and **FEATURE** are of practical interest. The first table maintains reference to all the tables used in the project. The second one contains information (names, codes, unique identifiers, etc.) related to all the features created by the user. The spatial data (**BODY** table in our case) becomes visible after this step in the Query tool in MS GG, i.e. it is possible to query and display the entire layer. In order to be able to post data in the database and to query individual objects, the table has to be linked to a spatial layer and the objects to features.

**2. Creating spatial layer** The table with the geometry (i.e. **BODY**) with geometry column **SHAPE** has to be referred to as a spatial layer in MS GG. Further, all the features that are to be associated with objects in this layer need to be assigned to the layer (again in MS GG). This operation extended our table **BODY** with nine new columns, all starting with ‘**BODY\_**’. We also added a ‘**mmlink**’ column (as primary key), since MS GG requires a column, named ‘**mmlink**’ with unique values to be able to query attributes:

<i>Column-name</i>	<i>Type</i>
<b>BODY_ID</b>	NUMBER(10)
<b>FACE_ID</b>	NUMBER(10)
<b>SHAPE</b>	MDSYS.SDO_GEOMETRY
<b>BODY_DFLAG</b>	NUMBER(10)
<b>BODY_UDL</b>	RAW(200)
<b>BODY_LOCK</b>	NUMBER(10)
<b>BODY_FID</b>	FCODE_LIST
<b>BODY_CREATED</b>	DATE
<b>BODY_REVD</b>	DATE
<b>BODY_RETIRED</b>	DATE
<b>BODY_XML</b>	XMLTYPE (or BLOB or VARCHAR2)
<b>BODY_TXT</b>	VARCHAR2(1024)
<b>MSLINK</b>	NUMBER(10)

**3. Linking features to spatial objects** First, one should make sure that the table with the spatial data (i.e. **BODY**) is declared in the table **MSCATALOG**. The project tables **CATALOG** and **FEATURE** are automatically registered in the **CATALOG** table by MS GG under entity numbers 1 and 2. Second, the column **BODY\_FID**

(in the BODY table) has to be populated. The FID (feature id) column contains all database linkages that are related to elements in a DGN-file. The column is an object of type Fcode\_list which is an array of Fcode\_item objects. *Fcode\_item* (*p1*, *p2*, *p3*, *p4*) provides the link between a feature (from FEATURE) and a particular spatial object (from BODY). The first of (in this case) two *fcode\_items* is related to the feature as it is described in the FEATURE table and the second to the spatial object from the BODY table. Parameter *p1* is the number of the table in the MSCATALOG (as it appears under the column ENTITY). Parameter *p2* is the number of the feature in the FEATURE table (given in the mslink column) in the first *fcode\_item* and the identifier of the object (i.e. FACE\_ID) in the second *fcode\_item*. The third parameter gives indication of whether the description is for feature (informational object) (i.e. 1) or spatial (non-informational) object (i.e. 0). Cases in which more than one feature refers to the same object are resolved by introducing a new *fcode\_item* in the *fcode\_list* description. The operation to fill the FID column can be performed either in MS GG or Oracle Spatial. Last, all the values in the column BODY\_LOCK (giving information about the owner of the data) have to be set to zero (i.e. belong to the owner of the table). A PL/SQL script completes these two operations within Oracle:

```
... FOR i in n..m LOOP
    UPDATE body SET body_fid =
        fcode_list (fcode_item (2,4,1,0), fcode_item (5,i,0,0))
    WHERE face_id=i;
    UPDATE body SET body_lock = 0 WHERE body_id=i;
END LOOP; ...
```

Note that in this case, one feature (i.e. number 4) is assigned to several objects, e.g. to attach the set of polygons to one 3D object.

### Geometrical data initially organised in MicroStation design files

3D objects that are initially stored in MicroStation dgn (design) files can be imported in Oracle Spatial directly by the three following major steps: 1) Create project, features, categories and spatial layers, 2) Select the entire geometry (polygons or groups of polygons) per spatial object in MS GG and attach a feature to it, 3) Post the spatial objects to the database.

In both approaches, after completing all the required steps, it was possible to query, visualise, edit and post the spatial objects as they are defined in Oracle Spatial (see figure 8.2). Evidently only spatial objects can be posted that are described with geometrical primitives that are supported in Oracle Spatial. A query can be specified either per layer or per feature and can be performed on the basis of the semantic characteristics of the objects as defined in MS GG. For example, query on feature ‘buildings’ will result in visualising all the buildings. Apparently, such possibility brings advantages for editing and updating large 3D models. Instead of working with the entire model, the user can query and work with only one object. Thus rendering of thousands of polygons can be easily avoided.

MS GG was able to visualise and edit both 3D geometrical representations (i.e. set of 3D polygons and 3D multipolygons) by following the steps described above. It should be noted that MS GG interprets the two representations in a different manner. In the first case the building is visually one object, but in the Oracle Spatial table, it is a set of individual polygons (figure 8.3). The entire building can be selected only by placing

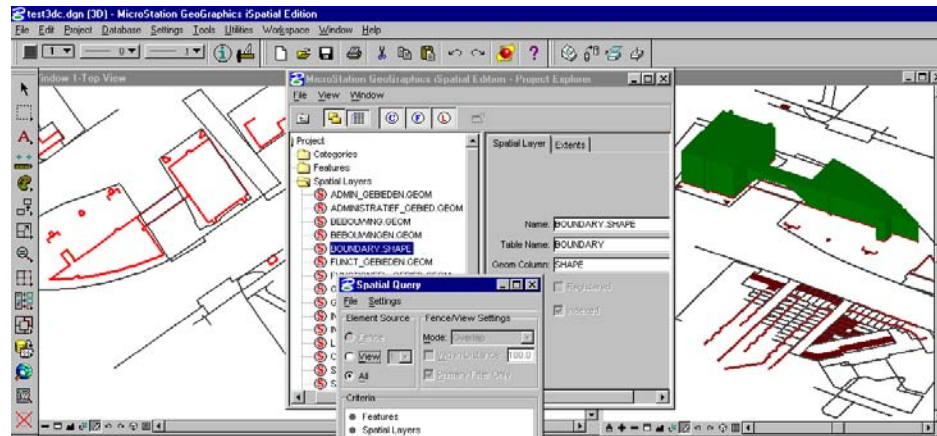

Figure 8.2: Querying spatial objects organised in Oracle Spatial, using MS GG.

a fence around all the polygons. In the second case, the building is one ‘group’, i.e. a single click of the mouse will highlight the entire building. In order to edit the object, however, the group has to be divided (‘dropped’ in MS GG terms) into individual polygons, i.e. the 3D object cannot be edited as a whole. To send the changes back to the database, grouping of the objects will be required again. Otherwise, the object will be considered as a set of several new polygons. It would be more efficient and less sensitive to errors to be able to edit the 3D object as it is defined, without dropping the element into 3D individual elements.

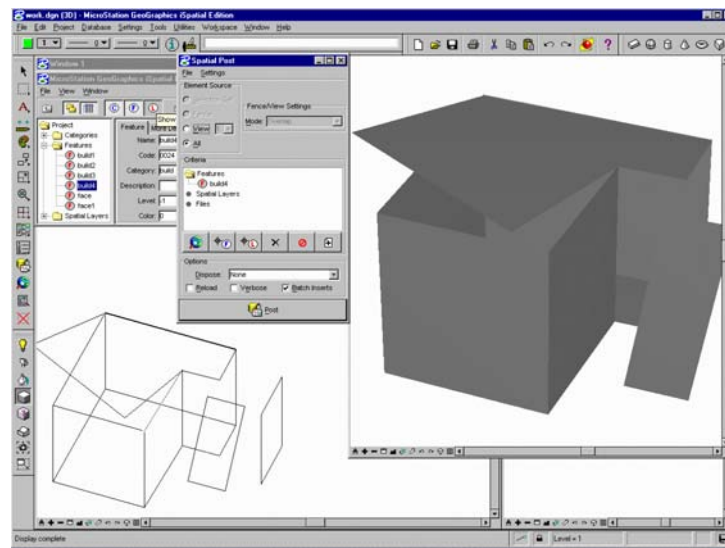

Figure 8.3: Editing and posting a 3D object as set of polygons using MS GG.

### Spatial Viewer

The Spatial Viewer is an example to show the possibilities of the MS GG API, in this case: an implementation of how to handle spatial information without a GG project. The Spatial Viewer is a Java applet and is delivered together with MS GG. The Spatial Viewer is especially meant to show the possibilities for implementing ones own data model.

Using the Spatial Viewer one can visualise, query and post (=update) elements. Also here, an mslink column containing unique numbers needs to be added and populated with unique values for accessing attribute data. The table name needs to be added in the MSCATALOG table to be able to post data. The Spatial Viewer reads the Oracle metadata table for available tables with geometries. In our example the relationship between mslink and face\_id is 1:1. In the case one would like to use another column as the key (e.g. body\_id for a reference to the whole 3D object), this can be achieved by using the available API. Using the Spatial Viewer, a MS GG project is not required, only the table MSCATALOG is needed and therefore the Spatial Viewer requires less customisation and less work for querying and posting data from Oracle. In addition the functionality can be adjusted to meet the user requirements. The main disadvantage of the Spatial Viewer is that it is not directly available in the menu of the MicroStation environment.

## 8.3 Accessing a geo-DBMS with a GIS front-end

ESRI software (ArcMap for 2D and ArcScene for 3D, both part of the complete package ArcGIS) [51], is able to access data that is stored as a sdo\_geometry type in Oracle with ArcSDE. ArcSDE is middleware that facilitates managing spatial data in a DBMS (IBM DB2, IBM Informix, Microsoft SQL Server, and Oracle). Originally ArcSDE was developed for the SDE binary format, which is a format for spatial data types in the DBMS (stored as BLOBs) developed by ESRI. Since spatial data types have become available in DBMSs, ArcSDE now also supports spatial data types. We did experiments to see if and how 2D and 3D geo-objects stored in Oracle Spatial can be accessed with ArcGIS version 8.3.

There are two methods to access data stored in Oracle Spatial via ArcSDE:

1. using SDE client/server software;
2. using 'direct connect', which does not use the SDE server, but only the SDE client software which is part of ArcGIS; the required SDE server functionality is included in the client software.

For the user who visualises the data both connections work similarly. The difference is the way the connection is defined and how the connection works behind the GUI. The 'direct connect' makes direct connection to the DBMS without using the ArcSDE application server. On the other hand, for the 'direct connect' one needs Oracle client software on the client platform (PC), which is not needed for the ArcSDE connection. According to the manual, the 'direct connect' is easier to install and maintain. However, for this connection one still needs the tables of the user 'sde' in

Oracle (the ArcSDE system tables) in combination with the Oracle Spatial metadata tables. An advantage of the ‘direct connect’ is that you do not need an ArcSDE licence to visualise data, in contrast with the SDE client/server connection. However, also in the ‘direct connect’ case one needs a license when one wants to edit the data.

The steps to visualise data organised in Oracle in ArcMap and ArcScene are:

1. insert metadata in the Oracle Spatial metadata table;
2. register the table that contains the geometry in the SDE system tables;
3. define the DBMS connection in ArcCatalog (the ArcGIS program for management of GIS-layers);
4. obtain the data in ArcMap or ArcScene.

**Step 1: Insert metadata in the Oracle Spatial metadata table** The insertion of metadata in the Oracle metadata table was shown in section 7.1.

**Step 2: Registering the table containing geometries** For both connections the table containing geometries needs to be registered as sde-layer. The registration of a table ‘test2d’ containing line features in a geometry column ‘shape’ and a primary key in the column ‘ID’ is registered as follows:

```
sdelayr -o register -l test2d,shape -k SDO.GEOMETRY -e 1
-u stoter -p password@database_name -i sde:oracle9i -c id -C USER
```

For 3D information, the element type should be polygons in 3D. Also multipolygons need to be supported. This is handled by the -e a3+ option (instead of -e 1); ‘a’ for area, ‘3’ for 3D and ‘+’ for multipolygons. Furthermore a keyword is needed that is available in the sde.dbtune table to describe the dimension and tolerance of the spatial layer, for example -k TEST3D (instead of -k SDO.GEOMETRY, which is the default). The registration of an sde-layer also works without an ArcSDE license and can be performed on both the client and the server. The registration only edits the sde tables stored in Oracle on the server. In these tables ArcSDE maintains the information of the geometry tables (dimension, spatial data types, geometry column). When the layer is ‘unregistered’ (with the sdelayr and the sdetable command) sometimes the Oracle metadata table is updated (i.e. entity for the table with geometry is deleted). This is not the way it should be since ArcSDE should only edit tables belonging to ArcSDE, and not tables that also exist without ArcSDE. The influence of a spatial index is also not clear. Without a spatial index a layer can be registered without any problems, however layers without indexes cannot be visualised. It is also not clear why ArcSDE does not (only) use the Oracle Spatial metadata table for the dimensions and the tolerances of the layers, but needs its own metadata table.

**Step 3: Define the DBMS connection in ArcCatalog** In ArcCatalog both DBMS-connections (ArcSDE connection and ‘direct connect’) need to be added: ‘add spatial database connection’. The connections are defined with the name of

the machine on which the database is stored, the name of the database, the user and the password of the user. The difference between the ‘direct connect’ and the SDE client/server connection is the service which specifies the type of connection: ‘sde:oracle’ for the ‘direct connect’ and the port number for the SDE client/server connection (usually 5151).

**Step 4: Obtain the data in ArcMap or ArcScene** The spatial data stored in Oracle can now be visualised and queried in ArcMap or ArcScene by means of the defined database connections. With the ‘add data’ option all tables that are accessible to the user are checked also tables that are not registered with sde and tables that do not contain geometry columns. This means that also tables owned by other users who have granted select privileges are checked, although ArcMap and ArcScene cannot do anything with the geometries in those tables as long they are not registered with ArcSDE. This is not optimal because for this query different sde tables need to be queried, which is time consuming. A better option could be to just query the Oracle Spatial metadata table of the specific user or only layers that are registered with ArcSDE. This is only one table and in this way the user can choose which (geometry) layers should be available for ArcGIS, although tables with no geometry are in this case not available.

The available layers are shown in the ‘add data’ dialog-window. The icons preceding the table-names show if the layer has been registered in ArcSDE and has therefore a geometry column that can be visualised in ArcScene or ArcMap (see figure 8.4). Also the data type (point, line or polygon) is indicated by this icon (as it has been defined during registration).

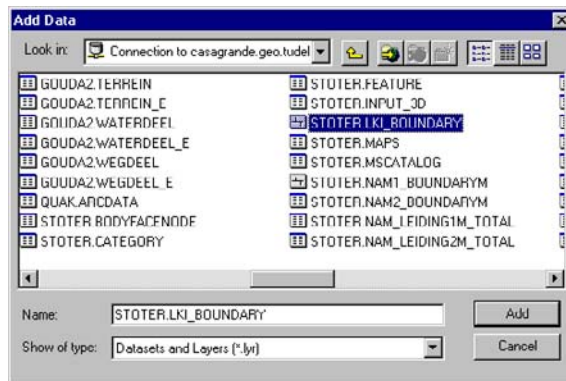

Figure 8.4: Dialog window in ArcMAP showing the tables stored in Oracle (note that the tables of users stoter, quak and gouda2 are all shown).

### Findings of accessing spatial data stored in Oracle with ArcGIS

2D data that is stored as an sdo\_geometry type can be visualised, queried and updated in ArcGIS with both connections, without modifying the geometry tables (e.g. adding columns) although in the sde registration process sometimes the Oracle metadata table is updated. There are some minor problems. A table cannot contain more than

one geometry column (for example when a bounding box is stored together with the geometries in one table or when a label point is stored for polygons). A solution to this might be to create different views for one table. Also only one geometry type per column is possible (so lines and polygons cannot be stored in the same `sdo_geometry` column of a table). Also in this case views, which only contain geometries of a specific ‘gtype’, might be the solution. When there is a geometry stored in the table that is not valid according to Oracle it might happen that none of the geometries in the table can be visualised. A last remark is that the primary key should be of type number(38) to avoid visualisation problems. This solution (adding primary key of type number(38)) is not straightforward and for a less experienced user hard to find in the manual.

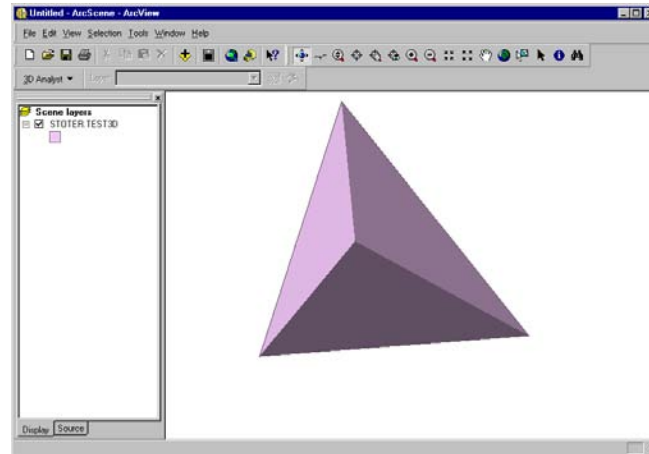

Figure 8.5: A tetrahedron defined by four separate polygons in Oracle, visualised in ArcScene.

Concerning 3D data, experiences showed that the z-values that are stored in Oracle are recognised by ArcScene (which is the 3D module of ArcGIS). Therefore it is possible to visualise 3D polygons (see figure 8.5). However, a problem in the visualisation is, that ‘vertical’ polygons (polygons that are perpendicular with the x,y plane) are not supported. This is due to the fact that ArcSDE first performs a validation on the geometry in the DBMS. Vertical polygons are not valid according to Oracle Spatial 9i since in 2D their area equals zero. Consequently vertical polygons cannot be accessed by ArcSDE. This is a major problem in urban modelling since vertical polygons are basic elements in models for buildings. It should be noted that ArcScene does support vertical polygons when they are stored in other formats, e.g. as multipatches or ArcView 3D shape format. Therefore when the spatial tables are converted into for example a 3D shape file, vertical polygons can be visualised in ArcScene. It also should be noted that 3D (or actually 2.5D) information can only be visualised and queried, and not edited with ArcGIS. It is possible to edit 2D spatial objects organised in a DBMS in ArcGIS, however ESRI, as other GIS software, does not have a graphical user interface to edit 3D data (although it is possible to individually change z coordinates per vertex in a special dialog).



## 8.4 Accessing a geo-DBMS using Web-technology<sup>1</sup>

Outside the GIS domain Web based tools have been developed both to access data that is organised in a DBMS and to visualise 3D objects via the Internet. To explore if these techniques can be combined to be used in the 3D cadastre prototypes, we built two prototypes using different Web technologies. The aim of the prototypes is to show the possibilities and constraints of accessing 3D geo-information organised in a geo-DBMS by means of Web based open standards and open source software. The advantages of using Web based technology are that it is free to use (no licenses are needed), and mostly also more easy to use for end-users. Therefore a larger public can get access to the data. Related research can be found in [8, 110, 123, 242].

For the prototypes we used VRML and X3D.

### 8.4.1 VRML and X3D

In 1994 the Web3D Consortium launched VRML (Virtual Modelling Language), which became an international ISO standard in 1997 (ISO/IEC 14772-1:1997). The basis for the development of VRML was to have a simple exchange format for 3D information. This format is based on the most used semantics of modern 3D computer graphics applications: hierarchical transformations, illumination models, viewpoints, geometry, fog, animation, material characteristics and texture. VRML is a language to describe 3D models and to make them accessible on the Internet. Interaction and visualisation is done by plug-ins for Web browsers (e.g. Cosmoplayer, Cortona [130]).

The development of VRML has stopped since the Web3D Consortium started to work on a XML version of VRML in order to integrate with other Web technologies and tools: X3D (eXtensible 3D). The specifications of X3D have become available in May 2003. In our research we use both X3D and VRML to visualise 3D geo-information.

The data structure of a X3D document is very much comparable to the data structure of a VRML file. As far as the underlying data model is concerned, X3D contains similar functionalities as VRML [229]. The difference lies in the notation (the syntax) used. While VRML is text, with accolades for structuring, X3D is coded in XML, with ‘tags’ for structuring. This is a major advantage for on-the-fly retrieval, because of the ease of use of XML in Internet applications.

For the prototypes we examined how 3D spatial objects with their non-spatial information can be displayed using VRML/X3D. For modelling the 3D polyhedral object we used the VRML/X3D geometry type IndexedFaceSet. In this type, first all coordinates of the 3D object are listed, then the faces of the 3D object are defined by references to the coordinates. Every face definition ends with -1.

For example the VRML code for a cube, defined with an IndexedFacedSet looks as follows:

---

<sup>1</sup>Part of this section is based on [205] and [225].

```
#VRML V2.0 utf8
Shape
{
  appearance Appearance {
                                material Material { }
  }
  geometry IndexedFaceSet {
    coord Coordinate {
      point [
        0 5 5,
        5 5 5,
        5 5 0,
        0 5 0,
        0 0 5,
        5 0 5,
        5 0 0,
        0 0 0
      ]
    }
    coordIndex [
      0, 1, 2, 3, -1,
      7, 6, 5, 4, -1,
      1, 0, 4, 5, -1,
      1, 5, 6, 2, -1,
      3, 2, 6, 7, -1,
      0, 3, 7, 4, -1
    ]
  }
}
```

There are basically two methods to display non-spatial information linked to 3D objects using VRML/X3D:

- using VRML/X3D for both spatial and non-spatial information;
- using VRML/X3D for spatial information in combination with HTML for non-spatial information.

Both methods will be explained using VRML. Since X3D is the XML-version of VRML and has the same functionalities, X3D supports similar functionality.

### Using VRML for both spatial and non-spatial information

In the first case, only one VRML file is created, which contains both spatial and non-spatial information for objects. Non-spatial information becomes visible as text in the VRML browser on ‘mouse-click’ or ‘mouse-on’ the object of interest. Figure 8.6 shows an example of viewing the attributes of an object (a building, represented as a cube). The text becomes visible when the user places the cursor on the building.

Since a VRML browser is not a complete GUI (the point-and-click operation is not a responsibility of the browser) the interaction has to be explicitly described in the VRML. This can be organised by two additional VRML nodes. First, a particular sensor (e.g. TouchSensor) has to be attached to the object (a Shape), which will monitor whether the cursor interacts with the object. Second, a billboard node has to be introduced to visualise the attributes in text format. In our example, we have designed a new ‘proto’ node. The node is basically a TouchSensor extended with a Javascript code (included in the VRML file), which controls the text that is visualised

(in our case attribute information). The code provides a link between the attributes and the geometry. This link needs to be defined for every object using the specific code. The VRML code for the example of figure 8.6 (see also [240]) is added in appendix A.

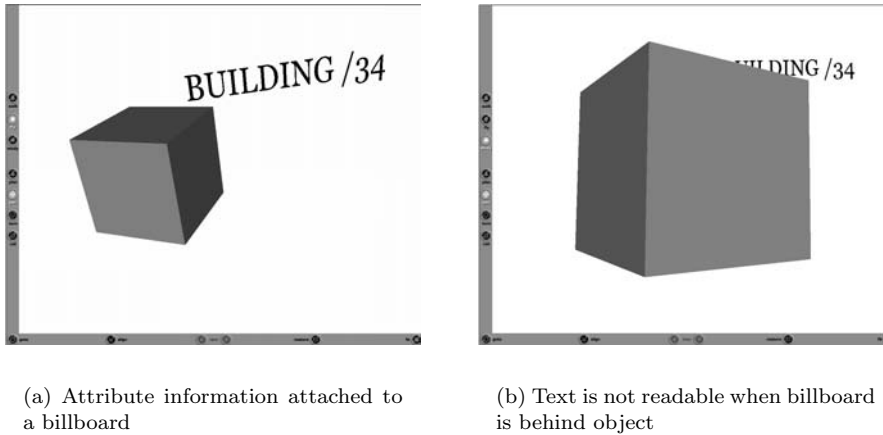

Figure 8.6: *VRML containing spatial and non-spatial information.*

The major drawbacks of this approach are related to the size of the file and the visualisation of the text.

Depending on the size of attribute information for visualisation and the number of spatial objects with attributes, the VRML file can become between 5 to 10 times larger compared to the VRML containing only the geometries. In case of large VRML models this can result in long time needed to create the VRML file (which is an important issue when creating VRML files on-the-fly), to transfer the file and display it on the screen. Since the attributes are visualised on a billboard (i.e. another 3D shape in VRML), they may be occluded by the object (see figure 8.6 (b)) or even invisible (if a user observes the billboard shape from a direction perpendicular to the axis of rotation of the billboard).

#### **VRML for spatial information and HTML for non-spatial information**

The problem of getting very large (and consequently slow-working) VRML files when including the attribute data in the VRML files, can be overcome by using HTML files for non-spatial information. Again the 3D object is represented as an IndexedFaceSet but now an anchor node is attached to every object. An anchor can be used to link an URL to an object. The anchor contains fields specifying the anchor. The complex object is defined within the anchor.

For every object a single HTML file is generated containing the attributes of the object. When one clicks on the object the corresponding URL (which indicates the specific HTML file) is opened in a frame defined in the parameter field of the anchor with the keyword “target=<frame>”. For one object the VRML fragment looks as follows (with the attributes stored in t\_1.htm):

```
Anchor {
  parameter "target=leftframe"
  description "Test 3D Cadastre"
  url "domain-name/attributes/t_1.htm"
  children [
    Shape {
      appearance Appearance {
        -----
      }
    }
    geometry IndexedFaceSet {
      coord Coordinate {
        point [
          -----
        ]
      }
      coordIndex [
        -----
      ]
    }
  ]
}
```

Using Web based technology to access spatial and non-spatial information stored in a DBMS, the information has to be converted on-the-fly into a format accessible for Internet clients. Therefore the VRML/X3D combined with HTML solution was selected for our prototypes since this solution promises better performance.

### 8.4.2 Prototypes

The basic idea of the prototypes is to organise 3D geo-objects in a DBMS and to query them via an Internet browser. Geo-objects contain both spatial and non-spatial information. The spatial information can be visualised after conversion into (dynamic) VRML or X3D and the non-spatial information can be presented in (dynamic) HTML pages. When using dynamic files, both the VRML/X3D files and the HTML files are generated on demand, which means they are not present on the Web Server or on the DBMS server. On a client's request a connection is made to the DBMS and the spatial information of interest is selected from the DBMS and converted into X3D/VRML. A browser plug-in at the client side makes it possible to view the VRML or X3D output. VRML and X3D provide the possibility to start a script when a user clicks on an object. This functionality is used to retrieve the non-spatial information that is linked to a 3D geo-object. Via the VRML/X3D plug-in a URL request is sent to a Web Server. The Web Server receives and interprets the incoming information, sends the request to the DBMS and sends a HTML with the required information back to the browser. For retrieving (and posting) the spatial and the non-spatial information from (and to) the DBMS a technique is needed to communicate between a client and a Web Server and between a Web Server and a DBMS server. For this communication,

several techniques are available such as ColdFusion and ASP (Active Server Pages). The choice of the used technique is dependent on the used Web Server.

To show the possibilities to query 3D geo-objects via an Internet client, first a simple prototype was built, based on Microsoft technology (MS Access, Microsoft Internet Information Server). The aim of this first prototype was to study functionalities of accessing non-spatial information stored in a DBMS linked to spatial objects using common Web technology. After good results of the first prototype, a second, more advanced prototype was built. In [240] an implementation of the same principles based on MySQL is described in combination with CGI (Common Gateway Interface) for the communication with the database and Apache as Web Server.

### Prototype I: ASP, VRML and MS Access

In the first prototype (see also [128]) only the non-spatial data can be dynamically retrieved from the DBMS. For the spatial information, a (static) VRML-file is created beforehand containing all the 3D geo-objects in the data set. This is not the optimal way to do it, since the VRML file may become very large in case of large data sets. A Java program was written which converts the spatial objects stored in the Simplified Spatial Model (see section 7.2.4) in the DBMS (Oracle) to a VRML file. For the prototypes we used a data set of the building complex of The Hague Central Station (see chapter 3), which is divided into 15 property units, stored as polyhedral objects (see figure 8.8 and figure 8.9 and section 12.1.2). For every object non-spatial information (such as ownership) is stored in MS Access. In this prototype Microsoft Internet Information Server 5.0 (IIS) is used as Web Server software and ASP (Active Server Pages, part of the Web Server software) for the communication between the Internet client and the DBMS server. For the communication between the MS Access database and ASP an ODBC connection is set up. The operations to obtain the information in the correct format are performed at the server and not at the client side (see figure 8.7). For the prototype we use an interface of an HTML page consisting of two frames, one frame to display the VRML data and the second frame to show the attribute information. The user opens the VRML file in the browser and when the user clicks on an object, a URL string containing the unique key for the object is sent to the server. The ASP page connects to the DBMS, retrieves the requested attribute information in HTML and sends it to the left frame as dynamic HTML.

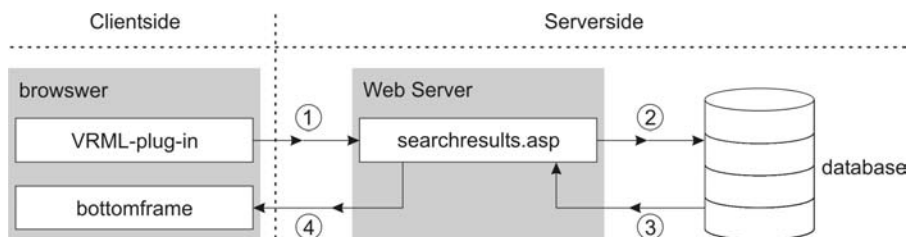

Figure 8.7: *Model of the architecture of the prototype.*

The URL string for object with id '5' looks as follows:

```
http://domain-name/searchresults.asp?id=5&submit=SEARCH
```

The URLs are linked to the objects by storing the URL string with the relevant parameters with every object in the VRML file using the anchor construction. ASP contains a method Request.QueryString. This method filters the needed parameters from the URL string that is sent to the server. In this case the unique id of the object. The ASP page also contains a SELECT statement to get the requested information from the database. In this case we defined the following (hardcoded) select statement (which could vary for different types of geographical objects):

```
SELECT object_id, section, parcel, level, owner, type_of_right
FROM 3D_rights
WHERE object_id = 'varName'
```

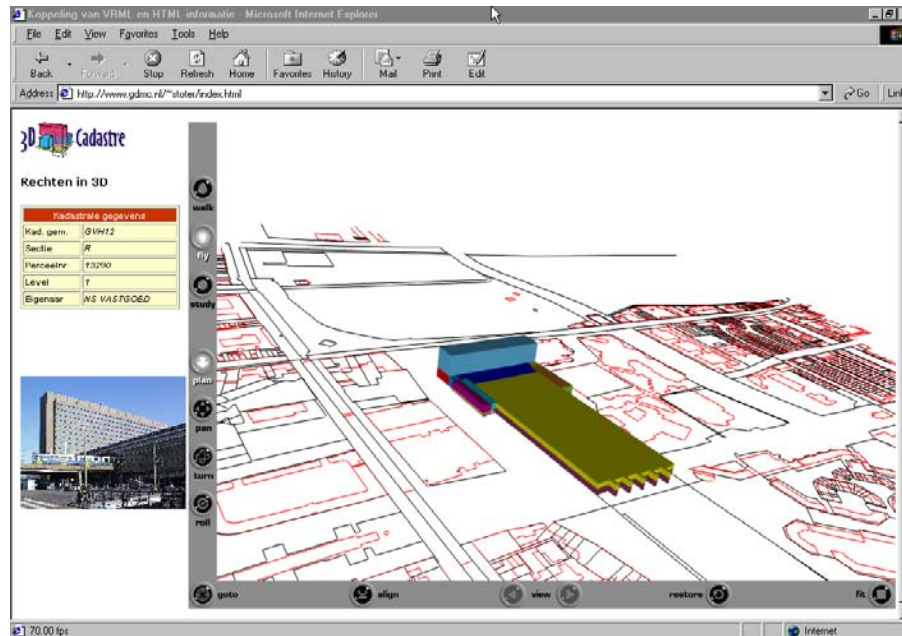

Figure 8.8: Screen dump of first prototype (ASP and VRML).

A screen dump of the prototype, using Cortona as VRML browser (see link in [130]), is shown in figure 8.8. This first prototype has three main disadvantages:

- The transformation of spatial information into the 3D format is not performed on-the-fly.
- The non-spatial data is stored in another DBMS than the spatial data. MS Access was selected for this prototype, to explore possible techniques.
- MS Access does not support spatial data types, although 3D objects could be stored in a topological model in MS Access.

To overcome these disadvantages a second, more advanced prototype was built.

### Prototype II: XSQL, X3D and Oracle

The second prototype is based on Oracle's XSQL Servlet and on X3D. The XSQL

Servlet is part of Oracle's XML Developers Kit (or XDK), aimed at 'XML enabling' Oracle's DBMS technology [211]. In this prototype both the spatial and non-spatial information is stored in Oracle. XSQL operates in combination with an XML Parser, an XSL processor (for the processing of XSLT stylesheets) and the XML SQL Utility (or XSU), also part of XDK. Servlets are Java classes that operate in a Web Server environment. They process requests that are passed to them by the Web Server when HTTP requests are received from a client. In this respect XSQL performs the same role as ASP in the prototype we described in the previous section (server-side processing). An XSQL 'page' is a combination of XSQL tags and SQL statements.

The fragment below shows an XSQL page with a select statement that returns all rows in a table. Variables are used for the connection (con), the geometry-column (geom), the table (table) and id (idcol) are used to make the statement generic. A where-clause for an attribute query or a spatial query to specify a subset of the data set, or any other standard SQL statement is possible as well.

```
<?xml version="1.0"?>
<?xml-stylesheet type="text/xsl" href="@xsldoc.xsl"?>
<mymap connection="@con" xmlns:xsql="urn:oracle-xsql">

  <xsql:query rowset-element="" max-rows="5000" >
    SELECT t.@geom.sdo_gtype AS gtype,
           t.@geom.sdo_elem_info AS info,
           t.@geom.sdo_ordinates AS geom,
           @idcol AS id
    FROM @table t
  </xsql:query>
```

An XSQL page has an .xsql extension. When the Web Server receives a request for an XSQL document, the page is passed to the XSQL servlet. The page is processed by the servlet: a connection to the database is made and the select statement is sent to the DBMS. The result set that comes back from the database is already in XML format. The second step is then to transform the 'raw' XML stream into a X3D or VRML output stream. Because of the XML syntax of X3D, the transformation from Oracle to X3D can easily be handled by XSLT stylesheets (see appendix B). Therefore in this prototype we used X3D. With the media-type set to "model/x3d+xml" the transformed output stream is recognised by the browser (at client side) as X3D, so that the right viewer plug-in (we used BS Contact, see link in [130]) can be activated for visualisation.

The way the XML output stream is transformed into X3D depends on the way the 3D geo-information is stored: when the data is topologically structured, a different XSLT stylesheet must be used then in the case of a non-topological model, when the geometry of each 3D object is stored in the object-record itself. In both cases however the same basic XSQL technology can be used. For this prototype the 3D spatial information is geometrically structured in the DBMS (Oracle Spatial 9i) using 3D multipolygons.

Getting the attribute information follows the same principle as in the first prototype: with the anchor construction of VRML/X3D a URL can be called if one clicks on an object, in this case the URL of another XSQL-page. The value and attribute name

of the link-id is passed to the XSQL page, together with the name of the Oracle table that has to be queried:

```
<Anchor parameter="target=left"
url="http://domain-name/fieldinfo.xsql?table=dh_3d&idcol=bid&id=1&con=st">
  <Shape>
    <IndexedFaceSet convex="false" solid="false">
      ...
    </IndexedFaceSet>
  </Shape>
</Anchor>
```

The non-spatial information is queried from the DBMS and translated into dynamic HTML. The XSQL servlet on the Web Server takes care of most of the steps in the retrieval process: establishing a JDBC connection to the database, sending the SQL queries to the database and - most important for our purpose - reformatting the SQL response (the result set of the query) into an XML output stream. This output stream can then be presented either as (dynamic) HTML (for attribute data), as SVG (Scalable Vector Graphics for 2D spatial data) or - as in this prototype - as X3D, for 3D visualisation. The configuration used in this second prototype is: Apache as Web Server software with Tomcat 4 as servlet container, XSQL for the server side processing, HTML and JavaScript for the user interface, and BS Contact as X3D viewer plug-in. Tomcat version 4 (and later versions) also contains Web Server functionalities, therefore this prototype could also have been implemented without Apache. The second prototype (figure 8.9) differs from the first in a number of aspects:

- X3D is used as 3D graphic format instead of VRML.
- The transformation into the 3D format is performed on-the-fly, with real-time access to Oracle (with the possibility to specify a subset, needed for large data sets).
- Spatial and non-spatial information are not in separate databases or database systems. Both 3D spatial and non-spatial information are stored in Oracle (in this prototype in the same Oracle table, but this is not necessary).

The second prototype is a more platform-independent solution than the first prototype. Because of the Java servlet technology it can be implemented on both Microsoft and Unix Web Servers. And although the XSQL Servlet is part of Oracle's XML toolkit, it can also be used to connect to other databases than Oracle (MySQL, PostgreSQL, etc.), provided that these databases can be accessed via JDBC connections.

### **OGC and our prototypes**

As was seen in section 6.7.1, OGC has defined Implementation Specifications for several types of Web Services. The question is, if these services can be used to make our prototypes OGC compliant.

There are several functionalities that are required in our prototypes that are built to visualise and query 3D geo-objects via an Internet client:

- to get sufficient insight in a 3D situation, it should be possible to *navigate* through the 3D representation of reality;



- it should be possible to *identify* objects (i.e. click on objects whereupon information on the objects appears);
- a user should be able to perform a *query*, e.g. give all 3D geo-objects of which the owner is Mr. X.

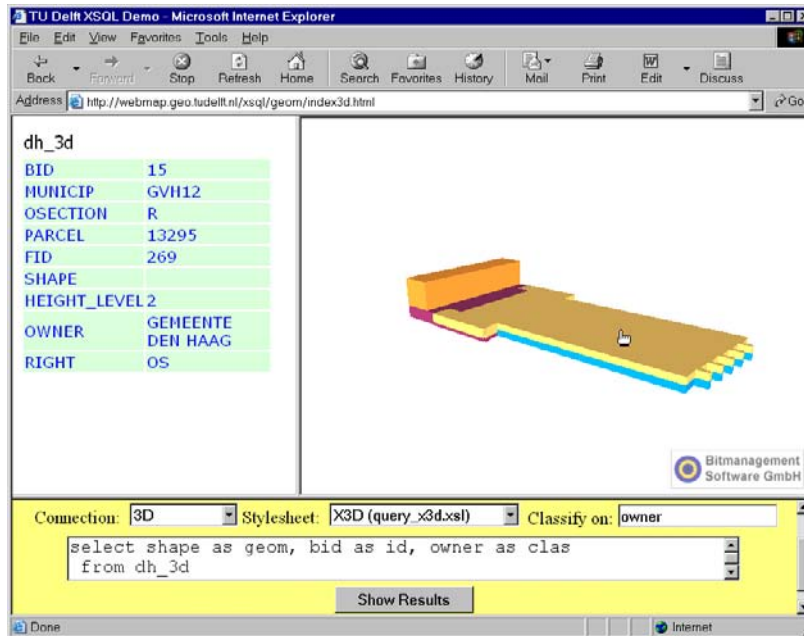

Figure 8.9: Screen dump of second prototype (based on XSQL and X3D).

Navigation using the Web Terrain Service (which returns an image of a 3D view) should in principle be possible. However, for navigation in a 3D model, a sequence of 3D view needs to be generated. This may result in low performance due to a lot of communication which is necessary between the Web Server and the client.

Identifying and querying of 3D geo-objects can only be supported by Web Services that support 3D geo-data and that are able to return the spatial data in vector-format.

At this moment only the Web Feature Service returns vector data (in GML), which means that only the WFS could be used to make our prototypes OGC compliant. Since GML also supports 3D features, 3D data can be returned to the client. The Web Feature Service does not only contain functionalities to visualise and query geo-data, but also supports transactions for the geometry and the alphanumeric attributes, by which it is possible to perform insertions, deletions and updates.

To be able to visualise, query and update the geo-data at client side using an OGC compliant environment, three architectures are possible (see also [226]):

- visualising and querying the 3D geo-data in a WFS enabled client (i.e. which directly supports GML format);

- the GML data is converted by middleware software or at the client side, to e.g. X3D or VRML, which may result in low performance compared to our prototype in which the conversion from XML to X3D was performed at the server side;
- extend GML with a 3D geometry type that is similar to the X3D data type 'IndexedFaceSet' (both X3D and GML are based on XML).

## 8.5 Conclusions

This chapter started with an overview concerning other basic aspects of 3D GIS than DBMS aspects: organisation of 3D data, 3D data collection and object reconstruction, visualisation and navigation in 3D environments and 3D analysing and 3D editing. Based on this overview it can be concluded that 3D GIS still has to mature. 3D GIS developments are mainly in the area of visualisation and animation. Bottlenecks for commercial implementation of 3D GIS are:

- 3D editing in GIS is not (yet) possible and is traditionally a functionality that is well supported in CAD software but not in GIS.
- Poor linkage between CAD, traditionally designers of 3D models, and GIS.
- Lack of methods to automatically reconstruct 3D objects.
- Visualisation of 3D information requires special techniques. Characteristics such as physical properties of objects (texture, material, colour), behaviour (e.g. on-click-open) and different levels of detail representations should also be maintained and organised in DBMSs.
- Virtual Reality and Augmented Reality techniques should be incorporated in GIS software to improve visualisation of and navigation in 3D environments.

In this chapter one of the functionalities of 3D GIS was addressed in more detail: accessing 3D geo-information organised in a DBMS (Oracle) by front-ends. From the experiments described in this chapter can be concluded that accessing geo-DBMS by front-ends is not (yet) always straightforward. With the CAD-oriented solution (Bentley's MicroStation GeoGraphics), it is possible to visualise 3D objects rather easily, but when one wants to query or edit objects one has to create features and attach features to the objects (the features and objects refer to the same 'thing'), which takes some more time and effort and which adjusts the database tables. The Spatial Viewer, which is a Java applet that enables to query, edit and post (=update) spatial data in Oracle Spatial without using a MS GG project, is delivered together with MS GG and requires less customisation and is therefore easier to use. Also using ArcGIS (a GIS solution) the user has to perform actions outside ArcMap/ArcScene before he is able to access spatial information in ArcMap and ArcScene. Another problem is that vertical polygons cannot (yet) be visualised in ArcScene. An advantage of the ArcGIS solution is that the database tables are basically not changed.

There are some basic differences between the solution of MS GG (also using the Spatial Viewer) and the ArcGIS solution. Firstly 3D editing using an interface is only possible in CAD oriented software and not (yet) in GIS software (z coordinates can only be adjusted in a special dialog). Secondly, when accessing the DBMS with MS GG the spatial data is retrieved and copied in the MicroStation design file. When the data

is updated, the data has to be posted back into the DBMS although in MS GG it is possible to set an option to immediately post modified elements or to force updates to Oracle Spatial when you close the dgn (MS GG design) file. When accessing the DBMS with ArcGIS one actually works on the DBMS (without copying the data).

We also described Web based access to the geo-DBMS, which illustrates how 3D visualisation techniques and techniques to query DBMSs via a Web Server can be combined. Accessing 3D geo-information via Internet is appropriate for the 3D cadastre in which easy and open access to the 3D situation, including 3D visualisation, is one of the main goals. Web based access to the geo-DBMS is based on open source software and open standards, which makes it independent of the underlying DBMS. In addition, many users can get access to the data without having to install (comprehensive) commercial software.

We have built two prototypes to show the possibilities of using Web based techniques. The prototypes showed how 3D geometry stored in an Oracle database can be converted into (dynamic) VRML or X3D, and how the 3D objects can be presented in a 'simple' Internet browser together with their non-spatial information which is presented in dynamic HTML. For accessing the spatial and non-spatial information the user does not need to carry out additional actions in contrast to the Bentley and ESRI solution. The next step is to see whether it is possible to use the OGC Web Services to make the prototypes OGC compliant. As was seen in this chapter, only the Web Feature Service would be suitable for visualising, querying and editing 3D geo-objects via the Internet.

The prototypes described showed good potentials for accessing 3D geo-objects organised in a DBMS which is an essential functionality for a 3D cadastre.



## Chapter 9

# Integrating 2D parcels and 3D objects in one environment<sup>1</sup>

The insertion of 3D geo-objects in the cadastral database containing 2D parcels touches the fundamental issue of combining 2D and 3D geo-objects (geographical features) in one environment: what is the vertical relation between 2D and 3D geo-objects and how can these two sources be integrated in one environment. These issues will be addressed in this chapter.

First it is discussed whether absolute coordinates or relative coordinates should be used to define 3D objects (section 9.1). A case study has been carried out to combine a 3D object (pipeline) with parcels. The aim of the case study is to show possibilities, problems and conditions of the integration of 3D objects and parcels in one DBMS environment. The case study is presented in section 9.2.

One of the main findings of the case study is that a height surface per parcel is needed to combine 2D parcels and 3D objects in one environment. Therefore four TINs (Triangular Irregular Networks) were generated, all representing surface height models based on point heights obtained from laser altimetry, and the last three also including 2D parcels: unconstrained Delaunay TIN, constrained Delaunay TIN, conforming Delaunay TIN and refined constrained TIN. In section 9.3 the creation of these TINs is described, together with their data structures and their results. The TINs were stored in the Oracle DBMS, and from this information, some spatial analyses, queries and visualisation were performed in the context of the DBMS (section 9.4).

One of the disadvantages of using a dense laser altimetry data set is the resulting data volume and with that the poor performance of queries. However, due to the ‘sampling’ nature of data obtained with laser altimetry not all points are needed to generate an accurate elevation model (within epsilon tolerance in the same order of magnitude as the original height model and cadastral data). Therefore we examined how the number of TIN nodes can be reduced by removing nodes that are not significant for the TIN taking the constraints of the parcel boundaries into account. Section 9.5

---

<sup>1</sup>This chapter is based on [197] and [199].

describes a method to generate an effective TIN that includes a data structure of 2D objects, in which only the relevant points are used. The first step of this generalisation method has been implemented: the filtering of non-significant elevation points. The results of this prototype implementation are presented in section 9.6.

This chapter ends with conclusions.

## 9.1 Absolute or relative coordinates

Two possible representations of z-coordinates of 3D geo-objects can be distinguished:

### **An absolute z-coordinate, defined within the national reference system**

When z-coordinates of 3D geo-objects are stored within a national reference system, absolute height has to be assigned to 2D surface parcels to be able to define geometrical and topological relationships between 3D objects and 2D surface parcels, such as above, below or intersecting. Since 2D parcels need to be defined in 3D space, the complexity of the 2D data increases. Locating 2D parcels in 3D space cannot be done by simply adding one z-coordinate per parcel, since some parcels may contain too much spatial variance for this approach (even in a flat country like the Netherlands).

### **A relative z-coordinate, defined with respect to the surface**

When z-coordinates of the 3D geo-objects are stored with respect to the surface, the current database does not need to be extended with additional z-information on 2D parcels, saving time and data complexity. The z-coordinates of 3D geo-objects known within the national reference system, have to be converted into relative coordinates. In this case only the 3D situation in the surrounding of the 3D geo-object needs to be explored (height data is only needed at the location of a 3D object), instead of locating all 2D parcels in 3D space. Maintaining data consistency in case of updates might be hard, for example when the surface level changes.

To assign height information to parcels, laserscan data can be used. Laserscan data of the surface is complicated to collect in urban areas (although filtering techniques exist to obtain height at surface level in urban areas based on laserscan data). Therefore, in urban areas with no height variances in surface level, defining z-coordinates of 3D objects with respect to the surface, i.e. using relative z-coordinates, (see for example figure 12.2, 12.3 and 12.5) might yield a good representation of the situation. In this case the surface level is the level where  $z=0$ . However, in most cases the most sustainable solution is to define 3D objects with absolute z-coordinates. Firstly because absolute z-coordinates are not influenced by surface changes. Secondly, the definition of the surface level (the reference level used for values with respect to the surface) is sometimes not clear, especially in dense urban areas with lots of modern constructions having their main entrance at different levels. Finally when using z-coordinates with respect to the surface it is complicated to define the actual geometry of 3D objects. In non-flat areas it is therefore not even realistic to define 3D geo-objects with respect to the surface.

Having decided that it is appropriate to have z-coordinates of 3D objects defined in absolute values, the next issue is how to combine the 3D objects with parcels defined in 2D.

## 9.2 Introduction of a case study

A case study was carried out to study the possibilities and constraints of combining a 3D object defined in absolute z-coordinates with parcels, by the integration of point heights and parcel boundaries (see figure 9.1). For this case study, the gas pipeline number 1 introduced in section 3.2.3 was used. The Company provided us with 3D information on the object (using absolute z-coordinates, in the Netherlands National Ordnance Datum: *NAP*).

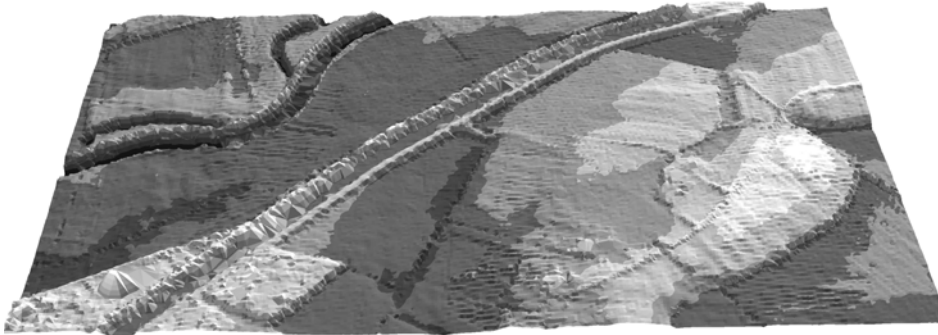

(a) AHN



(b) Cadastral parcels

Figure 9.1: *Data sets used in this case study.*

### 9.2.1 Description of data sets

For the case study two data sets were used: a registration of heights maintained by Rijkswaterstaat and the cadastral registration:

**Terrain height points** For the terrain elevation model we use a data set representing the DEM (Digital Elevation Model) of the Netherlands, i.e. AHN (*Actueel Hoogtebestand Nederland*) [72]. The AHN is a data set of point heights obtained with laser altimetry with a density of at least one point per 16 square meters and in forests a density of at least one point per 36 square meters. The point heights are resampled in a regular tessellation at a resolution of 5 meters. Since only the resampled data set was available, we used this regularly distributed data set. However, the TIN experiments described in this chapter are more appropriate for raw, irregularly distributed laserscan data. The AHN contains only earth surface points: information such as houses, cars and vegetation has been filtered out of the AHN. The heights in the AHN differ on average 5 cm with the heights in reality.

**Parcel boundaries** The used parcels are from the cadastral database of the Netherlands. In the cadastral DBMS parcel boundaries are organised in the geometrical structure (polylines) and parcels are topologically stored (see section 7.2.2). The typical geometrical accuracy is about 10 cm. The realised geometry of parcels (i.e. polygons) can be obtained by a function which has been implemented in the Oracle database (see section 7.2.2).

A test data set was selected from these registrations at the location of the pipeline (represented as polyline).

## 9.2.2 Combining point heights and 3D objects

Without the AHN, the 3D definition of the pipeline in absolute coordinates does not reveal where the 3D object is located with respect to the surface and with respect to the parcels on the surface. Is the pipeline situated above or under the ground, what is the depth of the pipeline? With point heights at surface level at sufficient density, it is possible to compute the position of the pipeline with respect to the surface. A DEM represented by an unconstrained TIN of the laser altimetry points (see section 9.3) was used for the extraction of  $z$ -coordinates at surface level at the location of the pipeline. The values for ‘with respect to the surface’ for every coordinate of the pipeline could be computed by subtracting the ‘ $z$ ’ value of the pipeline from the ‘surface’ value at the specific location. The results of these calculations are shown in table 9.1.

From this table we can see the depth of the pipeline, which shows that the beginning and the end of this pipeline are located above the surface, which is true in reality (the units are in meters while the diameter of the pipeline is 45 cm).

## 9.2.3 Assigning height to parcels

Figure 9.2 is a combination of 2D parcel boundaries (at the  $z=0$  plane) and the pipeline defined in 3D with absolute  $z$ -coordinates. The dashed lined shows the projection of the 3D pipeline on the plane where the  $z$ -coordinates equal zero (the plane where the 2D parcel boundaries are positioned). The 3D pipeline (which has absolute  $z$ -coordinates between +5 and +10 meter) is drawn above the parcel boundaries.



x	y	z_pipeline	surface_level	with_respect_to_surface
242850.36	512938.67	10.44	9.18	1.26
242849.52	512939.37	10.35	9.18	1.16
242847.21	512941.25	10.38	9.17	1.21
242844.80	512943.11	10.23	9.16	1.07
242843.01	512944.55	8.89	9.17	-0.28
242840.47	512946.54	7.33	9.17	-1.84
242820.76	512962.44	7.16	9.12	-1.96
242811.67	512969.86	6.93	8.96	-2.03
.....				
243433.04	516518.54	7.86	9.11	-1.23
243437.08	516499.08	7.89	9.04	-1.15
243437.59	516498.49	8.10	9.00	-0.90
243438.11	516498.19	8.37	8.99	-0.62
243438.58	516498.10	8.65	8.99	-0.34
243439.39	516498.22	9.16	9.01	0.15
243440.10	516498.36	9.58	9.02	0.56
243441.29	516498.62	9.99	9.04	0.95
243441.40	516498.64	10.10	9.0	1.05
243442.28	516498.83	10.27	9.04	1.23
243445.85	516499.61	10.37	9.07	1.30
243448.12	516500.04	10.46	9.10	1.36

Table 9.1: *Results of integrating 3D pipeline with DEM.*

However this is not correct since, apart from the entrances, the pipeline is located below the surface.

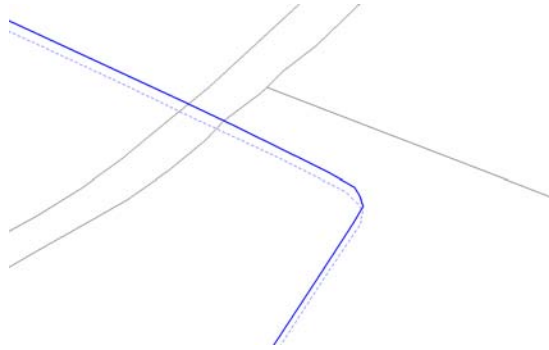
Figure 9.2: *Combining 2D parcels boundaries with a pipeline defined with absolute 3D coordinates.*

The alternative is to either locate the parcels in 3D space or to use relative heights (last column in table 9.1). Since we concluded already that using absolute z-coordinates for defining 3D objects is more appropriate for a 3D cadastre, we need to locate the parcels in 3D space. Using one z-coordinate for each parcel is not sufficient. There-

fore, z-coordinates were assigned to the vertices describing the parcel boundaries in order to locate the parcel boundaries in 3D. The DEM represented by an unconstrained TIN was used to extract z-coordinates for the vertices describing parcels (see section 9.3). Figure 9.3 shows different visualisations of the 3D pipeline and the 3D parcel boundaries. In figure 9.3 (a), the 2D parcel boundaries are drawn with dashed lines (on plane  $z=0$ ) in combination with 3D parcel boundaries. In figure 9.3 (b) the 3D parcel boundaries are drawn with the 3D pipeline (in absolute coordinates), which correctly reflects the real situation. Figure 9.3 (c) is the same as figure 9.3 (a), but now the pipeline in 3D is inserted with the projection of the pipeline on the  $z=0$  plane (dashed line), while sticks indicate the distance between the pipeline and the  $z=0$  plane.

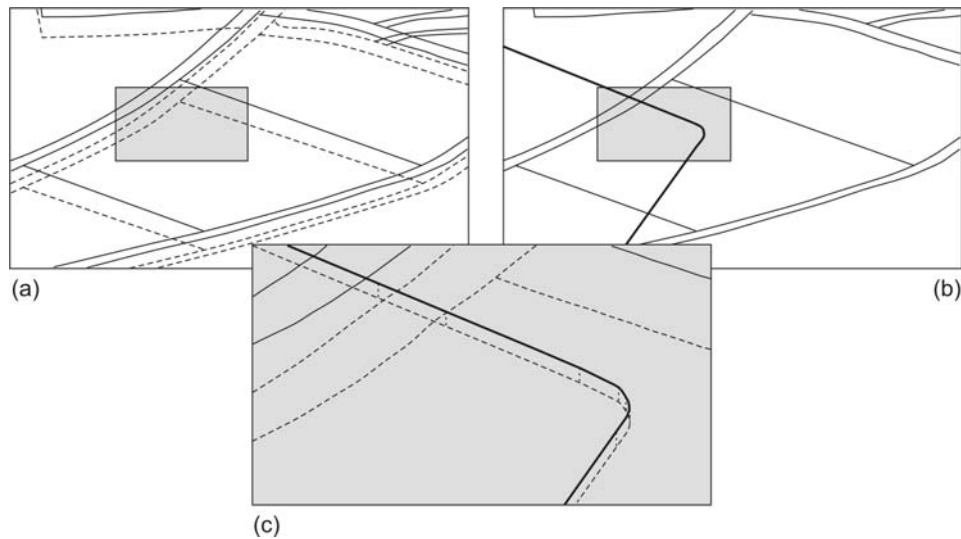

Figure 9.3: *Parcel boundaries defined in 3D give insight in where the pipeline is positioned with respect to the surface.*

On the locations of the parcel boundaries it is now possible to determine the depth (or height) of the pipeline. Interaction with the views (rotating, zooming, etc.) helps to better understand the situation. However, within one parcel it is still not clear where the pipeline is located. Therefore the parcel surface needs to be obtained. Having a height surface of parcels, it is possible to position parcels in 3D in order to integrate 3D geo-objects (defined in absolute height values) with the cadastral map and to extent the cadastral map in 3D using the 2.5D representation of parcels.

The height surface of parcels can be obtained by the integration of point heights and parcel boundaries.

## 9.3 Integrated TINs of point heights and parcels

First of all it should be noted that there is a close relationship between Digital Elevation Models (DEMs, 2.5D representations), based on for example raw laser altimetry point data, and the topographic objects or features embedded in the terrain. Feature extraction techniques seek to obtain the 2D geometry and heights for certain types of topographic objects such as buildings out of the DEMs. There are methods for object recognition in TINs (Triangular Irregular Networks) in which the selection of an object (e.g. building roofs, flat terrain between buildings) corresponds to planar surfaces [62]. This technique can be used for 3D building reconstruction from laser altimetry. This is not of particular interest for this thesis.

On the other hand, 2D objects coming from another source, such as a cadastral or topographic map, can explicitly be incorporated as part of the TIN structure that represents a height surface in order to integrate height information and 2D geo-data [103]. In this case the TIN structure is based on both 2D objects and point heights. The data structure of a planar partition of 2D objects is incorporated in the TIN structure. Within this data structure, the 2D objects are identifiable in the TIN and obtainable from the TIN, as a selection of triangles which yield 2.5D surfaces of individual 2D objects. To explore the possibilities of including a data set defined in a 2D planar partition in a TIN structure, four TINs, all representing height models and the last three also including 2D objects, were generated [189]:

1. Unconstrained Delaunay TIN, based on AHN point heights only.
2. Constrained Delaunay TIN, based on AHN point heights and constraints, which are the original edges from the 2D objects (parcel boundaries), without changing the input edges.
3. Conforming Delaunay TIN, based on AHN point heights and constraints (again edges of the 2D objects), now also Steiner points are added on long edges during the triangulation process to improve the triangle structure.
4. Refined constrained Delaunay TIN, based on AHN point heights and constraints, which are the original edges from the 2D objects that are subdivided before the triangulation process.

### 9.3.1 Unconstrained TIN

First a TIN was generated using only the point data. The triangulation was performed outside the DBMS since TINs (and triangulation) are not (yet) supported within DBMSs. The ideal case would be just storing the point heights and the parcel boundaries in the DBMS and to generate the TIN of the area of interest on user's request in the DBMS, without explicitly storing the TIN structure in the DBMS. The representation of the implicit TIN could then be obtained via a view. This would be more efficient and less prone to decrease in quality because no data transfer (and conversion) would be needed from DBMS to TIN software and back. In the future a distributed DBMS structure may be possible within the Geo-Information Infrastructure (GII). An integrated view, based on two different databases (as the point heights

and cadastral data are maintained by different organisations in different databases) may be feasible from the technical perspective. In our research we stored copies of all data sets in one single DBMS.

The TIN was generated by means of triangulation software called Triangle [188]. Triangle software was used, since it offers many types of triangulations and control parameters and in addition it is freeware software, written in C. There is a program by which it is possible to use it directly on the command line. The input as well as the output files are easily accessible since they are ascii files. Triangulation software implemented as part of GIS or CAD packages such as Geopak (Bentley [10]) or the 3D Analyst extension of ArcGIS (ESRI [51]) have their own internal data structure, especially for the produced TINs, which makes this triangulation software less flexible. In addition, Triangle supports more types of TINs, e.g. 3D Analyst does not offer support for constrained TINs. This is why these applications were not used in the first part of this research. Later on in this research (see section 9.6), 3D Analyst was used as it has an easy graphical user interface and it does support the conforming TINs, which is suitable for the purpose of our research at this stage.

CGAL [22], a freeware C++ library with computational geometry functions, does not have the option of building conforming TINs (only unconstrained and constrained TINs are supported) and in addition one still has to create a program (based on the library), which is why CGAL was not used.

In our test case, first an unconstrained TIN has been generated with Delaunay triangulation (see for an explanation [234]). The Delaunay triangulation results in triangles, which fulfil the ‘empty circle criterion’, which means that the circumcircle around every triangle contains no vertices of the triangulation other than the three vertices that define the triangle. In general this results in good and numerically stable polygons.

It should be noted that Delaunay TINs are not unique when more than three points are located on a circle. Further, it should be noted that the Delaunay TINs are computed in 2D and may therefore be suboptimal for true elevation data. The z-value of points is not taken into account in the triangulation process, but added afterwards. This is not straightforward if one realises that the TIN is computed for an elevation model in which the z-value is very important [220].

The resulting TIN (containing x-,y-,z-coordinates on point data and the TIN triangles defined with references to those points) are stored in the DBMS (Oracle Spatial 9i [160]) in a topological structure. The UML model of the TIN is shown in figure 9.4.

In the topological structure two tables are stored: a table with faces (TIN triangles): ‘tin’, and a table with nodes: ‘tin\_vertex’. Note that edges are not stored explicitly. The TIN triangle table contains references to the id’s in the node table (three references for every triangle):

```
SQL> DESCRIBE tin
```

Name	Type
-----	-----
ID	NUMBER(8)
PNT1_ID	NUMBER(8)
PNT2_ID	NUMBER(8)
PNT3_ID	NUMBER(8)

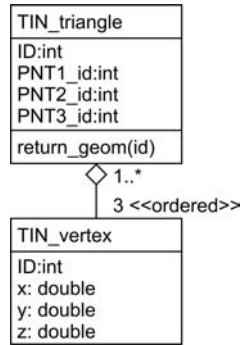

Figure 9.4: UML class diagram of TIN data structure.

In the integrated terrain elevation and object model defined with a constrained TIN, a conforming TIN or a refined conforming TIN, this table could also contain the object\_id (e.g. parcel number) indicating to which object the triangle belongs. In the second table the coordinates of the points are stored together with their id's:

```
SQL> DESCRIBE tin_vertex
```

Name	Type
ID	NUMBER(8)
LOCATION	MDSYS.SDO_GEOMETRY
Z	NUMBER(10)

In this way, every point is stored only once (sdo\_geometry is the Oracle spatial data type, which can also represent 3D points). A function has been written to generate ('realise') the geometry of triangles (3D polygons) based on the topological tables. The function returns a 3D polygon of type sdo\_geometry. The geometry is represented as a view on the topological structure by means of the following SQL statement:

```
CREATE VIEW tin_geom AS SELECT id, return_geom(id) shape FROM tin;
```

The selection of triangles from the unconstrained TIN (partly) overlapping one parcel surface represents an area larger than the parcel itself since triangles cross parcel boundaries (figure 9.5). Therefore, to improve the selection of a parcel surface, a constrained TIN was generated.

### 9.3.2 Constrained TIN

In order to obtain a more precise parcel surface, a constrained TIN was generated, using the parcel boundaries as constraints. Again the Triangle software was used (outside the DBMS). At first we did not divide the parcel boundaries (by adding points to the interior of constrained edges in order to fulfil the Delaunay criterion; see section 9.3.3). Therefore the original boundaries in the TIN were preserved. We

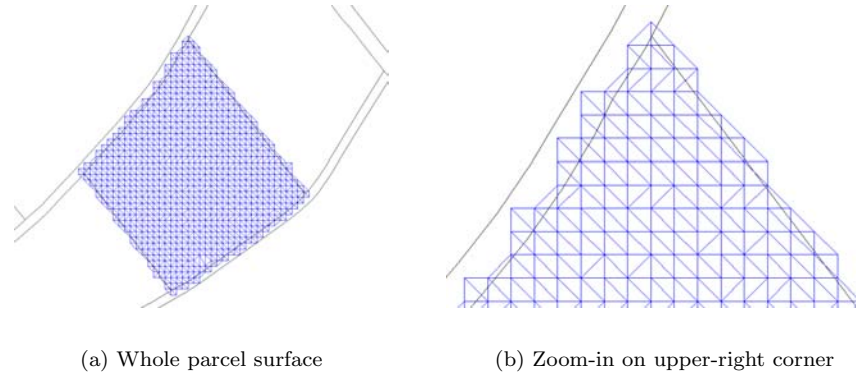

Figure 9.5: *A parcel surface extracted from the DBMS based on an unconstrained TIN.*

assigned z-coordinates to the nodes of parcel boundaries by projecting them in the unconstrained TIN. The constrained TIN is again stored in a topological structure, with a geometrical view on top of it. In the constrained TIN (figure 9.6) each triangle belongs to one parcel only and therefore the selection of triangles exactly equals the area of a parcel. To select a parcel-object from the TIN (as a set of triangles), the constrained TIN is more appropriate than the unconstrained TIN, since the data structure of the planar partition of parcels is incorporated in the constrained TIN. However, as can be seen in figure 9.6, keeping the edges undivided leads to elongated triangles near the location of parcel boundaries. This has two important drawbacks. First, the very flat elongated triangles may be numerically unstable (not robust, as small changes in the coordinates may cause errors) and the visualisation is unpleasant. Second, and may be even more important, a long original parcel boundary will remain a straight line in 3D even when the terrain is hilly, because there are no intermediate points on the parcel boundaries by which it is not possible to represent height variance across the parcel boundaries.

### 9.3.3 Conforming TIN

Keeping the original edges in the constrained TIN undivided in the triangulation process leads to elongated triangles if parcel boundaries are much longer than the average distance between DEM points (5 meters) which is the case in using parcel boundaries with the AHN data set. An alternative to the constrained TIN, may be the conforming TIN. The computation starts with a constrained TIN, but every constrained edge which has a triangle to the left or right not satisfying the empty circle condition is recursively subdivided by adding so-called Steiner points (and locally recomputing the TIN with the two new constrained edges). The recursion stops when all triangles, also the ones with (parts of) the constrained edges, satisfy the empty circumcircle criterion (the Delaunay property). The conforming TIN has both the Delaunay property and the advantage that all constrained edges are present, possibly

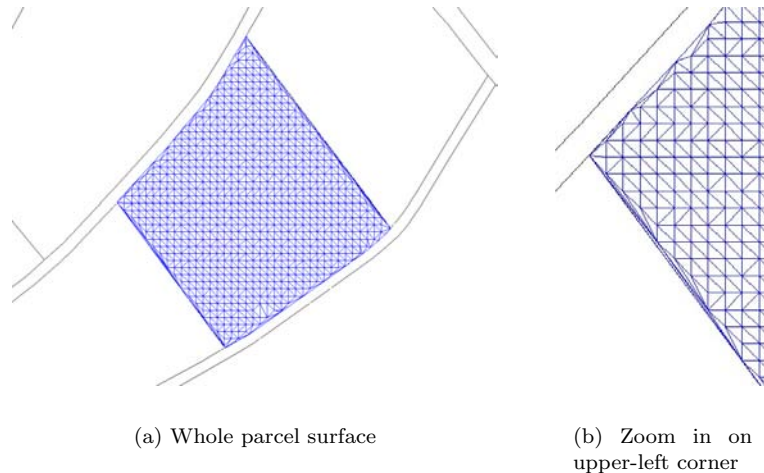

Figure 9.6: *A parcel surface based on a constrained TIN.*

subdivided in parts, in the resulting TIN.

The software Triangle uses the Ruppert's Delaunay refinement algorithm to produce conforming TINs [183]. In order to further improve (control) the shape of triangles, and the overall mesh, two additional parameters can be set (and it is possible to specify that the result is a conforming TIN):

- by specifying a minimum angle for the triangles (in 2D);
- by specifying a maximum area for the triangles (in 2D).

We did experiments with the data set to evaluate the two options. First, we generated a conforming TIN by setting the minimum angle for triangles and we choose a threshold of 10 degrees. Using the second option we generated a conforming TIN imposing a maximum triangle area. No triangle is generated larger than the maximum triangle area. The density of the height points is one point per 25 square meters. In case of grid-organised data (as in this case) the number of triangles in a TIN is usually approximately twice as large as the number of points, i.e. triangles have an area of 12.5 square meters on average. We therefore decided to set the maximum area on 25 square meters (see figure 9.7).

The disadvantage of both the minimum angle and the maximum area method is that data points are not only inserted on the edges of the parcel boundaries, but also in the mesh itself. Note that this problem becomes bigger if there are significant 'gaps' in the laserscan data set. Height points are added but these height points do not contain additional information, since the height of these added points are calculated during the triangulation process. Therefore, it was concluded that for our purpose the additional minimum angle and maximum area method are not beneficial and we used the normal conforming TIN. Figure 9.8 shows a conforming TIN, covering several parcels (colour coded). To improve visualisation the height has been exaggerated (10 times).

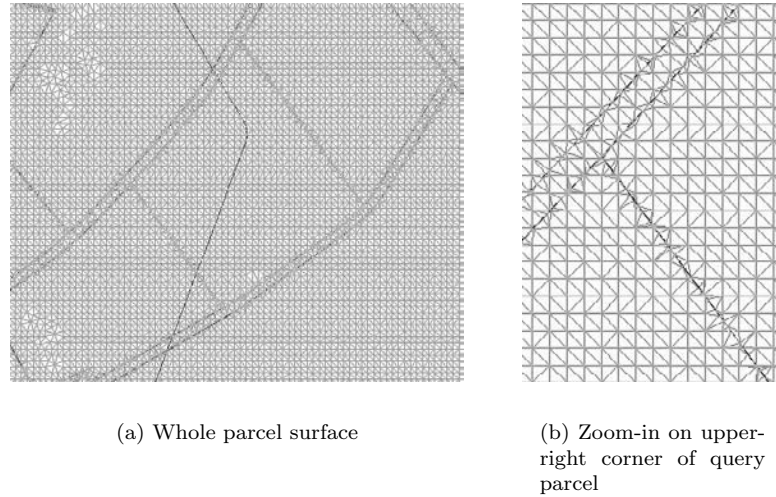

Figure 9.7: *A height surface based on a conformal TIN.*

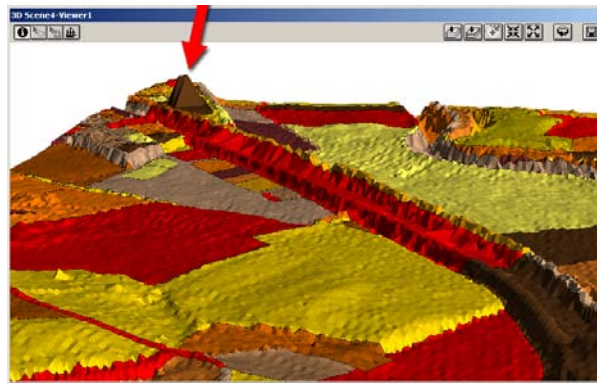

Figure 9.8: *Conforming TIN in which point heights and 2D planar partition of parcels are integrated.*

### 9.3.4 Refined constrained TIN

However, also a (normal) conforming TIN has its drawbacks compared to a constrained TIN. In case of two very close parallel constrained edges, a large number of very small triangles are generated while these constrained edges are split in many very small edges (see figure 9.9). This can also happen when AHN points are very close to the constrained edges. These small triangles have no use, as they do not reflect any height difference (at least the height differences cannot be derived from the AHN points) and they also do not reflect additional object information.



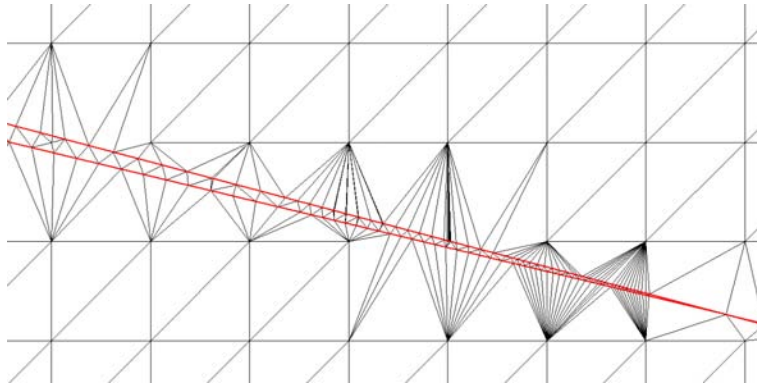
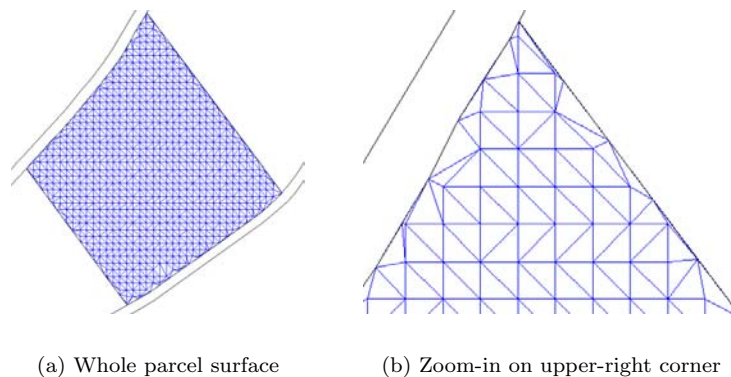

Figure 9.9: *In some cases a conforming TIN results in very small triangles.*

A solution for this is splitting the constrained edges, before inserting them, into parts not larger than two or three times the average distance between neighbour AHN points (e.g. 10 meters) and then computing the (normal) constrained TIN. In this way, on the one hand the too flat triangles of the constrained TIN are avoided (problem of very long constrained edges), and on the other hand also the too small triangles of the conforming TIN are avoided.

Figure 9.10 shows the refined constrained TIN for one parcel. The edges of the parcel boundaries were split into parts of at most 10 meters. These edges were then used as constraints in the triangulation, which resulted in a refined constrained TIN. This improves the shape of triangles considerably (too flat and too small triangles are avoided). Moreover, since points are added on the parcel boundaries for which the height has been deduced based on the unconstrained TIN, it is possible to represent more variation in height across a parcel boundary.



(a) Whole parcel surface

(b) Zoom-in on upper-right corner

Figure 9.10: *A parcel surface based on a refined constrained TIN.*

## 9.4 Analysing and querying parcel surfaces

The actual extraction of a parcel surface is performed within the Oracle DBMS. In this process all triangles that are covered by one parcel are selected by means of a spatial query. To select these triangles, first the realisation of the geometries of triangles needs to be performed. To illustrate the query to extract a parcel surface from the DBMS, the refined constrained TIN has been used. In these queries we used the realised geometries of parcels.

To speed up the query first a function-based index was built on the TIN table (R-tree index):

```
INSERT INTO user_sdo_geom_metadata VALUES('TIN_R', 'return_geom(id)',
mdsys.sdo_dim_array(
mdsys.sdo_dim_element('X', 0, 254330, .001),
mdsys.sdo_dim_element('Y', 0, 503929, .001)), NULL
);
CREATE INDEX tin_idx ON tin_r(RETURN_GEOM(ID)) INDEXTYPE IS mdsys.spatial_index;
```

The spatial query to find all points or triangles that are located within one parcel can be performed in two ways (in Oracle Spatial terms): with the spatial operator (`sdo_relate`) that uses a spatial index and the spatial function (`sdo_geom.relate`) that does not use a spatial index, (see section 7.3). The query to select triangles that are within a specific query parcel (number 4589, municipality GBG00, section D) using the spatial function, is:

```
SELECT tin_r.id, return_geom(tin_r.id) shape
FROM tin_r, parcels par
WHERE par.parcel=' 4589' AND par.municip='GBG00' AND par.section=' D' AND
sdo_geom.relate(par.geom, 'COVEREDBY+INSIDE',return_geom(tin_r.id),1)='TRUE';
```

For the unconstrained TIN we used the option `'ANYINTERACT'` instead of `'COVEREDBY+INSIDE'`, since otherwise we miss the triangles that cross parcel boundaries. The parameter `'ANYINTERACT'` returns TRUE if the two geometries are not disjoint. Two objects are `'DISJOINT'` when the objects have no common boundary or interior points.

### 3D area of parcel surface

The cadastral map is a 2D map containing projection of parcels. Consequently the cadastral map does not contain the true area of surface parcels. In mountainous countries the true area of parcels may be needed, since tax rates are based on the area of parcels. The integrated TIN based on point heights and parcel boundaries provides the possibility to obtain the true area of a parcel.

The area of a parcel in 3D space can be computed by summing up the true area of all triangles covering one parcel in 3D space. Chapter 7 showed that DBMSs do not support 3D data types and consequently they also do not contain functions to calculate the area in 3D. To be able to compute the area of triangles in 3D in Oracle, the function `'area3D'` that was implemented as part of the 3D geometrical primitive (section 7.4) was used. The 3D area calculation could therefore be performed inside the DBMS.

First we calculated the 2D area of the original parcel polygon. The query parcel is the parcel with a small ‘hill’ on it (see figure 9.8):

```
SELECT sdo_geom.sdo_area(geom, 0.1) FROM parcels
WHERE parcel=' 4589' AND municip='GBG00' AND section=' D';
```

The area in 2D is 6,737 square meters. The 3D area of the same parcel, which resulted in 6,781 square meters, is performed with the following query:

```
SELECT sum(area3d(return_geom(id)) FROM tin_r tin, parcels par
WHERE parcel=' 4589' AND municip='GBG00' AND section=' D'
AND
sdo_geom.relate(par.geom, 'COVEREDBY+INSIDE',return_geom(tin.id),0.1)='TRUE';
```

As can be seen from these results, the difference between the projected area and the real area in 3D of this parcel is 44 square meters.

Other queries can be performed as well, e.g. find steepest triangle, find all triangles pointing to the south, or find the highest (lowest) point in this parcel:

```
SELECT MAX(z), MIN(z) FROM tin_vertex, parcels par
WHERE par.parcel=' 4589' AND par.municip='GBG00' AND par.section=' D'
AND
sdo_geom.relate(par.geom, 'COVEREDBY+INSIDE',location,0.1)='TRUE';
```

MAX(Z)	MIN(Z)
-----	-----
14.24	10.027

## 9.5 Generalisation of the integrated TIN

Both the conforming TIN and the refined constrained TIN (with constraints based on subdivided parcel boundaries in order to avoid long straight lines) look promising: the triangles are well shaped (not too flat and in case of the conforming TIN, the Delaunay criterion is fulfilled) and points are added on parcel boundaries in order to represent more height variance on them. However, after some analyses we suspected that far too many points are used in order to represent the surface TIN with the same horizontal and vertical accuracy as the input data sets (AHN points and cadastral map). A problem of having huge data sets is the resulting data volume and with that poor performance of queries and analyses. Therefore filtering of the data set aiming at data reduction (generalisation) is needed.

The filtering aiming at data reduction, i.e. generalisation, is based on filtering the TIN structure and not the point heights themselves. The filtering can use the characteristics of the height surface. On location with little variance in height, points can be removed while on the location with higher variances points are maintained to define the variance in height accurately. Important advantages of data reduction in a TIN structure are that it can be used on irregularly distributed points and that locations

with high height variance will remain as such in the new data set. Unfortunately we were not able to start with an irregularly distributed data set, by which we were not able to use all advantages of the filtering performed on the TIN structure. However, the result data set is an irregularly distributed data set.

This section describes two methods to improve the initial integrated height and object model: a detailed-to-coarse approach (section 9.5.1) and a coarse-to-detailed approach (section 9.5.2). In section 9.5.3 a more advanced generalisation method of the integrated model is discussed (that is, more than based on height only).

### 9.5.1 Detailed-to-coarse approach

The first method starts with the complete integrated model. From this model a number of non-relevant point heights are removed while maintaining the significant points, e.g. removing the points where the normal vectors of the incident triangles have a small maximum angle. After removing such a point, the triangulation is locally corrected and it is explicitly checked if the height difference at the location of the removed point in the new TIN is within this tolerance. If so, the point is indeed not significant for the TIN and can be removed. In this process the parcel boundaries are still needed as constraints, since the aim is to be able to select a parcel surface from the TIN.

The prototype implementation is based on this method (section 9.6). The result of the generalisation using the prototype is shown in figure 9.11.

### 9.5.2 Coarse-to-detailed approach

The procedure described above starts with all available details and then tries to remove some of the less relevant details, which is not always easy. An alternative method would be starting with a very low detail model and then adding points where the errors are the largest. The initial model could be just the constraints (with estimated z-values at every vertex of the parcel boundary) inserted in a conforming or refined constrained TIN. In the next step the AHN height point with the largest distance to this surface is located. If this point is within `eps_vert` distance from the surface (maximum tolerance in the vertical direction defined in `epsilon` tolerance), then the model already satisfies the accuracy requirements. If this point is not within the tolerance, then it is added to the TIN (and the TIN is re-triangulated under the TIN conditions). This procedure is repeated until all AHN point heights are within the tolerance distance. This procedure is a kind of 2.5D counterpart of the well-known Douglas-Peucker [33] line generalisation.

### 9.5.3 Integrated height and object generalisation

Until now, only the height was taken into consideration during the generalisation process, both in the detailed-to-coarse and coarse-to-detailed approach. However, as the model is supposed to be an integrated model of height and objects, also the objects

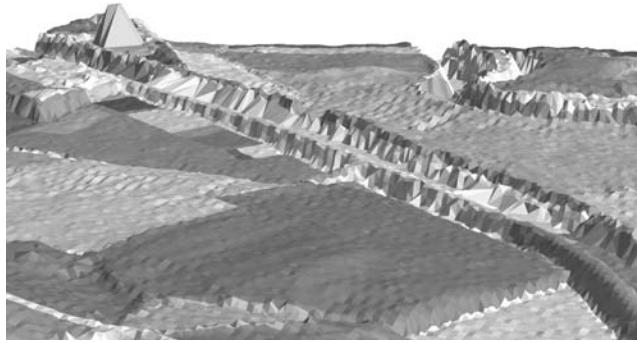

(a)

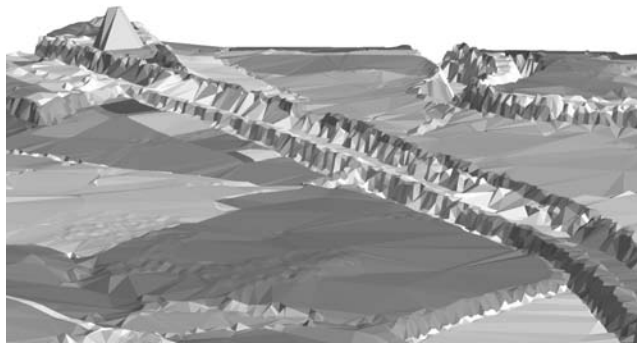

(b)

Figure 9.11: *Conforming TIN in which point heights and 2D planar partition of parcels are integrated, before (above) and after (below) filtering.*

should participate in the generalisation. Therefore the integrated height and object model could be further generalised by taking into account both the elevation aspect and the 2D objects at the same time. It is already possible to separate generalisation of the terrain model [14, 18, 88, 164] and 2D objects [33, 134, 141, 166, 177, 192, 235]. However, the integrated generalisation of the height and object model makes this model also well suitable for other resolutions (scales) or even in a multi-resolution context.

Starting with the detailed-to-coarse approach one could identify the following steps:

**Step 0:** Integrate raw elevation model (AHN) and objects (parcel boundaries) in a (conforming or refined constrained) TIN, see section 9.3.

- Step 1:** Improve the efficiency of the TIN created in step 0 by removing AHN points from the TIN until this is not longer possible given the maximum tolerance value in the vertical direction: `eps_vert_1` (as described in section 9.5.1). Note that this tolerance could be adjusted for different circumstances, but the initial value should be the same size as the accuracy of the input data.
- Step 2:** Now also start generalisation of the object boundaries, for example with the Douglas-Peucker line generalisation algorithm, by removing those boundary points which do not contribute significantly to the shape of the boundary. This can be done in 2D (standard Douglas-Peucker), but it is better to apply this algorithm in 3D. Keep on removing points until this is impossible within the given tolerance in the horizontal direction: `eps_hor_1`. After this line generalisation of the constraints, re-triangulate the TIN according to the rules as in step 0 (of a conforming or refined constrained TIN).
- Step 3:** Finally, for multi-resolution purposes, also start aggregating the objects, for example in our case: parcels to sections (and the next aggregation level would be sections to municipalities, followed by municipalities to provinces, etc.). In fact this is removing some of the constrained edges (original parcel boundaries) from the input of the integrated model. Repeat step 1 and 2 with other values for the epsilon tolerances at every aggregation level with their own tolerances in the vertical and horizontal direction: `eps_vert_2`, `eps_hor_2` (at the section level), `eps_vert_3`, `eps_hor_3` (at the municipality level), ....

## 9.6 Generalisation prototype

The first steps (step 0 and step 1) of the generalisation method have been implemented in a prototype. The fundamental idea of the implemented filtering method is to detect characteristic points (detailed-to-coarse approach). Points that are not characteristic, i.e. they do not contribute significantly to the height surface, will be removed. The question whether points are characteristic, is in the prototype dependent on the following conditions:

- A point is characteristic if the slope of two neighbouring triangles of the point are significantly different [18]. To detect this, the normal vectors for the neighbouring triangles are determined and compared. If the difference is bigger than a given threshold angle, the point will be defined as characteristic and not be removed from the TIN.
- Local minima and maxima are also characteristic points of a TIN. If two neighbouring triangles are in the same direction in the first condition, the change in angle is less important than where the change in angle demarcates a top or a valley. Therefore, a smaller threshold angle is used when the specific point is a local minimum or maximum. A minimum or maximum is the case when the azimuths of the slope of two neighbouring triangles are opposite of each other, which can be determined by calculating the differences in the azimuths. If the difference is bigger than a given threshold value, a smaller threshold angle is used in the first condition.

Based on these conditions a point is maintained or removed. If two neighbouring triangles of one point already fulfil one of the criteria, the point will be maintained. The next step is to look if the removal of a point can be justified. This test is done by calculating the height difference at the location of the removed point between the original TIN and the new TIN (which is generated based on the reduced data set). If this difference is bigger than a threshold value the removed point is re-added. After this step the data reduction is performed again, i.e. the data reduction is an iterative process until the process is stopped on user request, preferably when a more or less stable data set is obtained (e.g. when all points have been found to be characteristic).

The prototype has been implemented in the 3D Analyst extension of ArcView (ESRI) using the macro language of ArcView (avenue). In ArcView the TIN is recognised as an object and therefore the TIN data structure can be used directly in the reduction algorithm and in addition the results can easily be visualised. This prototype shows already the possibility of data reduction on a TIN, but should be implemented as part of the database in the future, once a TIN data structure is supported as data type in a geo-DBMS.

For our initial test, the data reduction is performed on the unconstrained TIN. This means that the 2D objects and the point heights are kept separately during the data reduction process in order to get a first impression of the achievable results. Incorporating the constraints at this stage would have made the data reduction process more complex. Figure 9.11 shows the conforming TIN of our test data set, after filtering. We did experiments with different parameters. The parameters that showed best results were:

- minimum angle between two neighbouring triangles to be a characteristic point if a point is not a top or a valley: 4.5 degrees;
- minimum angle between two neighbouring triangles to be a characteristic point in case of a top or valley: 3 degrees;
- difference in azimuth between two neighbouring triangles to determine if two triangles are opposite of each other: 120 degrees;
- maximum allowed difference in height to determine if a removed point should be re-added: 0.25 meters.

Apart from the minimum angle, the chosen parameters are based on previous research [167].

The data set used in this example covers an area of 1450 by 800 meters and contains 44,279 AHN points (maximum z-value 14.2 meters, minimum z-value 6.7 meters, mean 9.5 meters). Three iterations steps were used to filter the data set. Figures 9.12 and 9.13 clearly illustrate how the filtering maintains all terrain shapes but reduced the number of points substantially (height is exaggerated ten times).

In the first iterative step, 34,457 AHN points were removed (9,822 were considered to be characteristic). The average height difference between the original and the new TIN was 0.09 meter. 3,243 points were re-added since they exceeded the height difference of 0.25 meter, which resulted in 13,065 points after the first step. After the second iteration step 8,697 points were determined as characteristic, the average height difference between the new and the original point was again 0.09 meter, 3,469

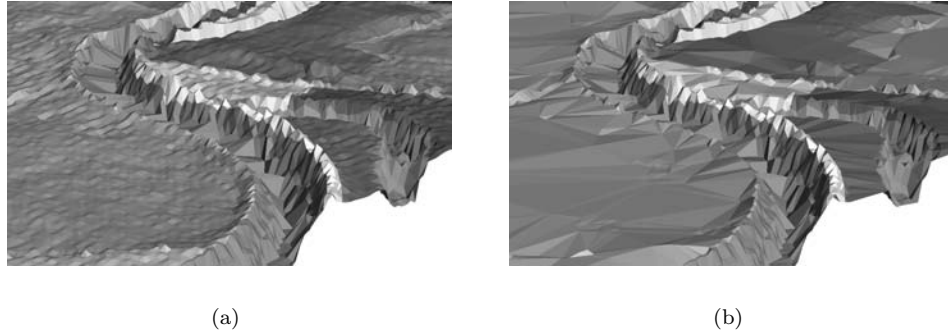

Figure 9.12: *Detail of filtering results: before (left) and after (right) data reduction.*

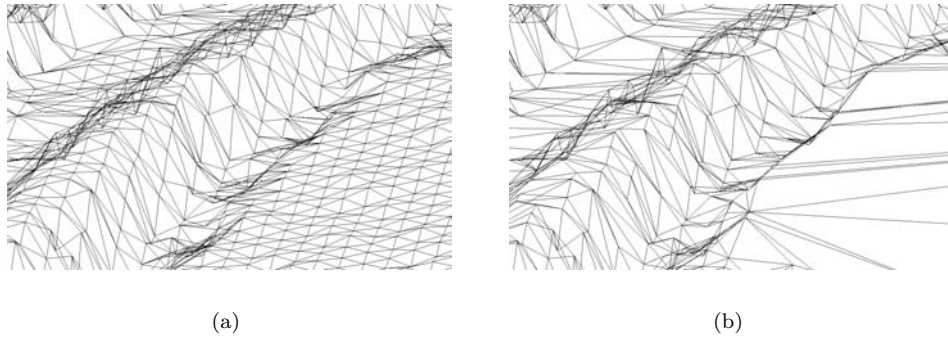

Figure 9.13: *Detail of filtering results: before (left) and after (right) data reduction.*

points were re-added and this all resulted in 12,166 points. After the third iteration step, 8,455 points were considered to be characteristic (average height difference 0.09 meter) and 3,529 points were re-added. After this step the data reduction process was stopped. The results of the data reduction process are listed in the following table:

it step	# points	# rem points	# char points	# re-added points	red rate
1	44,279	34,457	9,822	3,243	70%
2	13,065	4,368	8,697	3,469	73%
3	12,166	3,711	8,455	3,529	73%

After the total data reduction process 11,984 points from the original 44,279 points were maintained. This is a reduction of 73%. As can be seen from figure 9.14, points were removed from areas with little height variance, while density of point heights in areas with high height variance (e.g. on the dikes) is still high.

The experiments with the prototype on the selected data set yielded a number of conclusions. The minimum angle needs to be adjusted to characteristics of the terrain:





Figure 9.14: *Result of data set after data reduction (points not removed are black).*

in case of many points in relative flat area, the minimum angles needs to be small in order to avoid clusters of removed points being re-added since they exceed the maximum allowed height difference. A small minimum angle avoids removing at least one of the points in the cluster. In this case the new TIN is more equal to the original TIN, therefore removed points do not exceed the maximum height difference condition and they are not re-added. In terrain with more height variance, larger minimum angles are needed in order to remove more points. In mixed terrain (with both areas with low height variance and areas with high height variance, which will often be the case), a balance should be found. In the future one could think of an implementation that can differ the parameters during one data reduction process based on the local height variance.

## 9.7 Conclusions

A basic aspect of a 3D cadastre is to combine 3D objects with parcels in the DBMS. This combination makes it possible to indicate where a 3D object is located with respect to the surface level (what is the depth/height of a 3D object at this location?) and with respect to parcels on the surface.

It was concluded that defining 3D objects with absolute z-coordinates (instead of using z-coordinates with respect to the surface) is the most sustainable way of defining 3D objects. Using absolute values for 3D objects, height surfaces of parcels are needed to be able to combine the parcels and the 3D objects.

Incorporating the planar partition of 2D objects, e.g. the cadastral map, into a height surface makes it possible to extract the 2.5D surfaces of 2D objects and to visualise 2D maps in a 3D environment by using 2.5D representations.

As described and discussed in section 9.3 it is not easy and straightforward to create a good integrated elevation and object model. Several alternatives were investigated, unconstrained Delaunay TIN, constrained TIN, conforming TIN, and finally refined

constrained TIN. After some analyses, the most promising solution, the refined constrained TIN, was selected and applied with success to our test case with real world data: AHN height points and parcel boundaries.

The integrated model however, contains too many AHN points, which do not contribute much to the actual terrain description. Therefore we proposed a method to generalise the integrated model. This method takes both the elevation aspect and the 2D objects into account at the same time. We implemented the first step of this method into a prototype. In this prototype non-characteristic points are removed from the (unconstrained) TIN in an iterative generalisation process. As can be concluded from experiments with the prototype, it is possible to determine important terrain characteristics by using a simple criterion (difference in angle of neighbouring triangles). With this method it is possible to reduce the data set considerably. The test data contained about 4 times less points after filtering, but still within the epsilon tolerance of the same size as the quality of the original input data sets. On the other hand significant information on the height surface is still available in the TIN. The initial filtering yielded therefore a much-improved integrated model. Improvements can be expected when removed points are not re-added collectively but one-by-one or when the used parameters can differ during one data reduction process, based on local terrain characteristics.

The integrated model is a good basis to obtain a 2.5D representation of 2D parcels (2D parcels draped over a height surface). This is required when combining 3D objects and 2D parcels in one environment.

## Part III

# Models for a 3D cadastre



# Chapter 10

## Conceptual model for a 3D cadastre<sup>1</sup>

In the previous chapters the need for a 3D cadastre and the conceptual and technical framework for modelling 2D and 3D situations were studied. These chapters sketched the juridical, cadastral and technical frameworks where a 3D cadastre, to some extent, should fit in.

Based on the theory and findings in the previous chapters, this chapter will come to a design of a conceptual schema for a 3D cadastre. Three possible concepts (with several alternatives) have been distinguished to register 3D situations. These three concepts will be introduced in section 10.1. The three conceptual models for 3D cadastral registration with their alternatives are further completed in sections 10.2 to 10.4.

The solutions proposed in this chapter are considered both using (Dutch) cadastral criteria and technological criteria in section 10.5. Based on these considerations the best concepts for 3D registration are selected.

The chapter ends with conclusions.

### 10.1 Introduction of possible solutions

The term ‘3D cadastre’ can be interpreted in many ways ranging from a full 3D cadastre supporting volume parcels, to the current cadastre in which limited information is maintained on 3D situations. Here three fundamental concepts are distinguished (with several alternatives): the most advanced solution, the most simple solution and one in between in which 3D situations are still registered within the current cadastral and technical framework:

- Full 3D cadastre:

---

<sup>1</sup>Part of this chapter is based on [202].

- Alternative 1: combination of infinite parcel columns and volume parcels, (i.e. combined 2D/3D alternative)
- Alternative 2: only parcels are supported that are bounded in three dimensions (volume parcels)
- Hybrid cadastre:
  - Alternative 1: registration of 2D parcels in all cases of real property registration and additional registration of 3D legal space in the case of 3D property units
  - Alternative 2: registration of 2D parcels in all cases of real property registration and additional registration of physical objects
- 3D tags linked to parcels in current cadastral registration

### 1. A full 3D cadastre

This means introduction of the concept of (property) rights in 3D space. The 3D space (universe) is subdivided into volume parcels partitioning the 3D space. The legal basis, real estate transaction protocols and the cadastral registration should support the establishment and conveyance of 3D rights. The 2D cadastral map does not lay down any restrictions on 3D rights, i.e. rights that entitle persons to volumes are not related to the surface configuration. Rights and restrictions are explicitly related to volumes. Apartment units will be real estate objects defined in 3D, on which a subject can have a right in rem. The full 3D cadastre requires a change in the juridical way of thinking as well as in the cadastral and technical framework. For a full 3D cadastre, the same UML model as described in section 2.2 applies. However, the real estate object may now also be defined in 3D. Two alternatives are distinguished for the full 3D cadastre. In the first alternative volume parcels (bounded parcels) are only established in 3D situations and therefore it is still possible to establish parcels that are defined with boundaries on the surface. The first alternative starts with the conversion of the conventional representation of parcels into the third dimension: a parcel defined by the boundary on the surface is converted into an infinite (or actually indefinite) parcel column that intersects with the surface at the location of the parcel boundary. In the first alternative, two types of real estate objects are distinguished: infinite parcel columns (which still apply in ‘classic’ 2D situations) and volume parcels. In a complete implementation of a full 3D cadastre (second alternative), the only real estate objects that are recognised by the cadastre are volume parcels (bounded in all dimensions) and the volume parcels form a complete partition of space. In the second alternative of the full 3D cadastre, it is no longer possible to entitle persons to infinite parcel columns defined by boundaries on the surface, but only to well-defined, totally bounded and surveyed volumes.

### 2. A hybrid solution

This means preservation of the 2D cadastre and the integration of the registration of the situation in 3D by registering 3D situations integrated and being part of the 2D cadastral geographical data set. This results in a hybrid solution of the legal registration (2D parcels) and a registration of the 3D situation. The separate registration of the legal and the 3D situation are combined and integrated. The cadastral registration of the 3D situation gives insight, but is not juridically binding: the exact legal situation has still to be derived from authentic documents (deeds, survey sheets) recorded in the land registration. In those deeds, both the buyers and sellers

have to agree on the description of the volume to which the new owner is entitled. This description can then be used in the 3D registration. The 3D representation (see figure 10.1) can be either the volume to which a person is entitled (first alternative) or a physical object itself (second alternative).

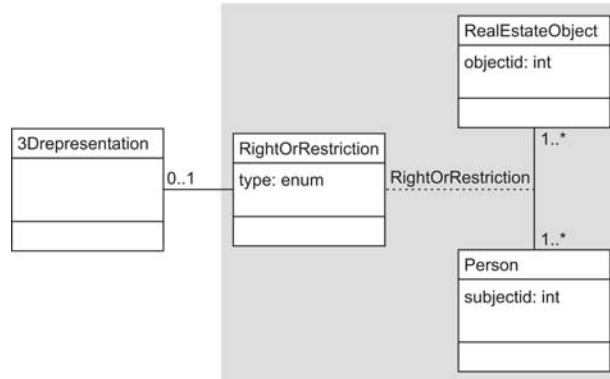

Figure 10.1: *UML class diagram of the hybrid cadastre. The 3D representation refers to either a volume to which a person is entitled or a physical object.*

The first alternative implies the 3D registration of rights that are already registered and that are concerning 3D situations using 3D right-volumes. This alternative is seen as a tool to get insight in the 3D aspect of rights (i.e. visualisation of rights in 3D as part of the cadastral geographical data set which can consequently be queried). The second alternative is the registration of physical objects themselves by which constructions are integrated in the cadastral geographical data set in the same way as buildings in the current cadastral registration: in addition to parcels to clarify the real situation. In the case of 3D right-volumes (first alternative), the parcel is the starting point of registration (which limited rights are established on this parcel?), while in the case of 3D physical objects (second alternative) a physical object is the starting point of registration. In both alternatives the juridical and cadastral concept of ownership and property is not changed as in the full 3D cadastre: rights are always established and registered on 2D parcels, while an owner of a parcel can be restricted in using the whole infinite parcel column by limited rights and legal notifications. Consequently rights for 3D property situations are established in the same way as in current (Dutch) practise. The difference is the way these rights are registered (and visible) in the cadastral registration.

### 3. 3D tags in the current cadastre

This means preservation of the 2D cadastre with external references to (digital or analogue) representations of 3D situations (figure 10.2). Complex 3D situations are registered using ad hoc solutions within current registration possibilities, while every right that is registered can be attributed with a reference to a 3D representation. The difference with the hybrid cadastre is that the 3D representations are maintained separately, not integrated with the cadastral geographical data set.

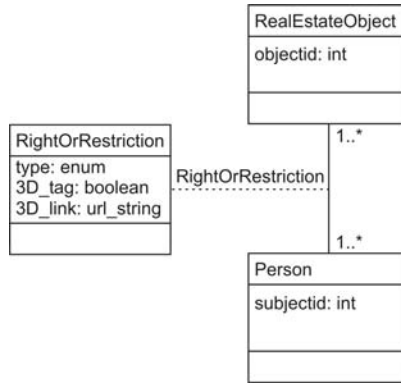

Figure 10.2: *UML class diagram of 2D cadastre with tags to 3D situations.*

In the following sections, we will further concretise these conceptual models for a 3D cadastre. We will start with the solution that requires the least fundamental changes of the current cadastral concept: 3D tags in the current registration (section 10.2), followed by an elaboration on the hybrid approach (section 10.3). The conceptual model for a full 3D cadastre will be further completed in section 10.4.

## 10.2 A 2D cadastre with 3D tags

In the ‘3D tag’ solution, real rights to real estate are always established and registered on 2D parcels. However, the notification of the existence of a 3D situation can be added to the registration by registering a 3D tag on the parcel. This means that every parcel that has more than one person entitled to it can be indicated as a 3D situation. In addition to the tag, a reference can be added to a legal document or to a drawing that illustrates the situation. The reference can be implemented in various ways. The simplest solution is to just tag 3D situations in the cadastral registration whereupon the user has to consult the documents in the land registration to find detailed information. A more advanced option is to add a reference to a 3D (digital) description maintained in the cadastral registration. The description is maintained in the cadastral registration in analogue or digital form (e.g. a CAD-drawing). In the latter case the information can be included (as file) in the cadastral database. The projected outlines of the 3D physical object can be inserted into the cadastral geographical data set. The main difference with the hybrid solution is that drawings of 3D situations can only be examined per parcel: no integrated view on the whole situation is possible. Furthermore the 3D situations can only be visualised and not queried since the property units indicated in the drawings do not have a link to the administrative database. This registration is more or less similar to current practise of subsurface constructions in the Netherlands where subsurface constructions can be indicated using an ‘OB’ (underground construction) code. This ‘OB’ notification does not clarify the juridical situation; it is just an indication of the factual situation.



## 10.3 The hybrid approach

The hybrid approach consists of a registration of 3D situations in addition to, and integrated with, the existing 2D parcel registration. To effectuate this approach two alternatives have been designed. The first alternative focuses on improving insight in the 3D extent of rights (section 10.3.1) and the second alternative focuses on the registration of physical constructions (physical objects) (section 10.3.2).

### 10.3.1 Registration of 3D right-volumes

A 3D right-volume is a 3D representation of the legal space related to a (limited) right (or apartment right) that is established on a parcel and concerns a 3D situation, for example a right of superficies established for a tunnel. The right of superficies, established for a tunnel, refers to a volume below the surface. The landowner is restricted in using the whole parcel column and the volume that is ‘subtracted’ from this parcel column is visualised in 3D as a 3D right-volume as part of the cadastral map in a 3D environment. The cadastral map should then be converted into 2.5D (see chapter 9). 3D right-volumes refer only to ‘positive’ right-volumes. If a person obtains a right for a bounded volume on a parcel (positive right-volume), this volume is subtracted from the parcel column owned by the landowner (negative right-volume). The right-volume is only registered for the person which is entitled to the bounded volume, while the spatial extent of the property of the bare owner can be derived from the registered information.

One should note that a 3D right-volume is a different entity than 3D right as used in the full 3D cadastre, since the juridical framework is not changed. Rights are still always established (and registered) on surface parcels, while in the full 3D cadastre, in case of a 3D right, a person is explicitly entitled to a well-defined volume (real estate object defined in 3D), which is no longer related to surface parcels.

The boundary of the 3D representation of a 3D right-volume starts with the parcel boundary since (in the Netherlands) a right is always established on a complete parcel. If more detail is required, e.g. when a parcel intersects with two tunnels in opposite corners of the parcel, the parcel needs to be subdivided, which is also practice in current cadastral registration (see section 2.5.2). A 3D right-volume is extended into 3D (‘extruded’) by means of defining the upper and lower limits of the right. The upper and lower limits of 3D right-volumes are initially defined with horizontal planes. This type of registration is sufficient to warn the user that the landowner is restricted in using the whole parcel-column. It also gives an indication on the space to which the limited right applies. More precise information (with juridical status) can be obtained from deeds and survey plans archived in the land registration. The question can be posed if more detail on upper and lower limits of 3D right-volumes (variance in z-level) is needed. More variance in the x,y plane is restricted by the Dutch Law on the Cadastre [43] that defines that a limited real right of use on a parcel always entitles a person to the complete (2D) parcel, otherwise a new parcel needs to be created. If it will be possible in the future to register a real right on only part of a parcel, a 3D right-volume can be defined as a polyhedron located anywhere within a parcel. The first aims of 3D right-volumes are to warn the users that something

is located above or below the surface and to indicate approximately the space where this ‘something’ is located. The prototype implementations will show if the simple definition of 3D right-volumes already satisfies these aims and to what extent.

In the Netherlands, legal conclusions can only be drawn from deeds and not from the cadastral registration. However most frequent use will be based on querying the cadastral registration without examine the source document (deed or survey document). Therefore the quality of the 3D representations should be exact enough for practical use.

All the parties involved should agree on the upper and lower levels of the 3D right-volumes. The levels should be laid down precisely in the concerning deeds and survey plans. Based on this information the 3D right-volumes can be generated and inserted in the cadastral registration.

The 3D right-volumes that are maintained are associated with a registered right. The collection of 3D right-volumes that make up a whole 3D real estate object (e.g. one tunnel) is also maintained, and the 3D right-volumes contain references to this whole real estate object. This is done because then all 3D right-volumes belonging to one real estate object can be derived (with an administrative and not a spatial query). One cannot perform this query in the current cadastral registration, as there are no references to the whole real estate object maintained.

The UML class diagram of 3D right-volumes is shown in figure 10.3. For every right that is established on a parcel and that concerns a 3D property situation (more users on a parcel) a 3D right-volume is maintained. The right-volume is only referenced as positive right-volume (for the holder of the right) and not for the holder of the ownership right that is restricted by the right-volume (bare owner). The 3D right-volume is a 3D representation of the right, of which the geometry is maintained in the DBMS as type `gm_solid`, which is a geometry type defined by OGC and ISO [152], see figure 10.4. As one sees, this data model needs only little adjustment compared to the current cadastral data model (figure 2.2).

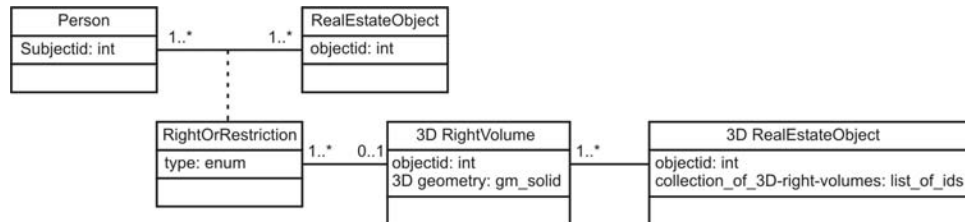

Figure 10.3: *UML class diagram of 3D right-volumes.*

The most basic improvement of the registration of 3D right-volumes compared to the current cadastral registration is that the 3D extent of rights can be visualised in one integrated view in the cadastral map and not only per parcel in isolated visualisations. Furthermore, the 3D situations can be queried since the 3D right-volumes are linked to non-spatial information in the cadastral database in contrast to the (scanned) drawings available in a cadastre containing only tags to 3D situations. However,

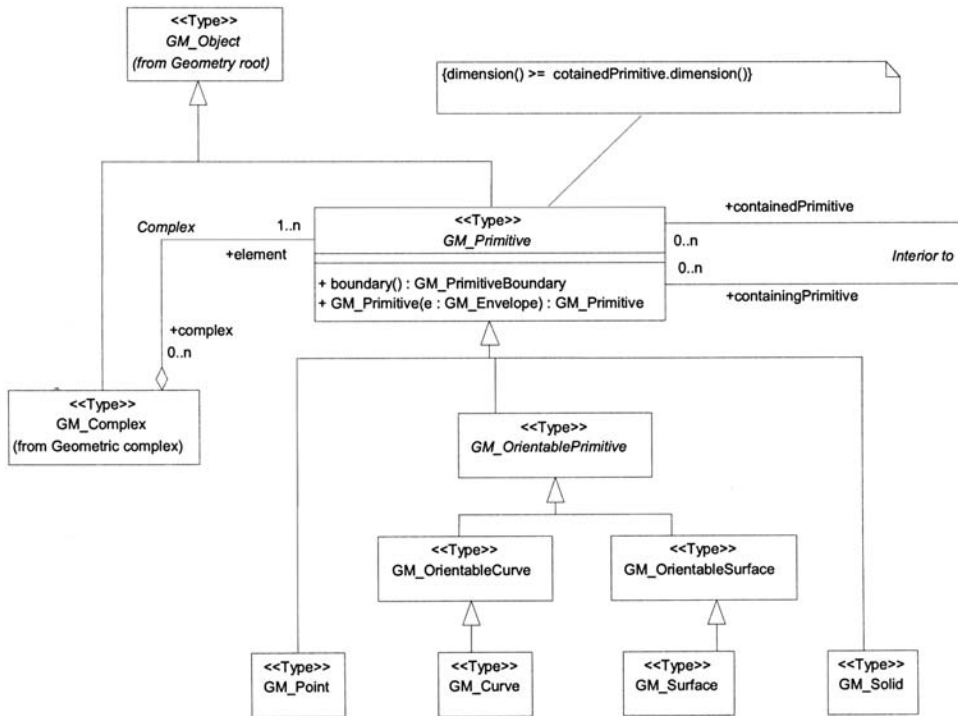

Figure 10.4: UML class diagram of *gm\_primitive* as defined by OGC and ISO, taken from [152].

the solution has also two drawbacks, especially when physical objects cross parcel boundaries.

A 3D right-volume can only be registered, when a right is established that will be registered in the cadastral registration, e.g. in the case of a limited real right or in the case of a real estate division in apartment rights. In other cases, a 3D right-volume will not be registered. For that reason it is possible that the 3D location of the whole real estate object is not (and does not have to be) completely known in the cadastral registration. This can be illustrated by the example of a railway tunnel. This tunnel is built in the underground of six parcels. The owner of the tunnel (the company ‘T’) is also full owner of two of these parcels. The other four parcels are owned by respectively A, B, C and D. For each of these parcels a right of superficies is established. In this case a 3D right-volume because of the tunnel is registered for four surface parcels. Not for the two parcels owned by T. Consequently the tunnel, which is registered by means of 3D right-volumes, will not be locatable on the cadastral map in detail at all locations (see also figure 5.2 (c)). Another drawback of 3D right-volumes is that it cannot correctly reflect all 3D situations because of the simple representation of horizontal boundaries, e.g. in the case there are two tunnels above each other (road and metro) at the same location, both with varying *z*. The simple representations of right-volumes (with horizontal upper and lower boundaries) would

intersect each other, while the legal spaces do not intersect (see also figure 11.1).

To meet these complications, a second alternative of the hybrid cadastre was designed, which focuses on the registration of physical objects.

### 10.3.2 Registration of 3D physical objects

Insight into 3D situations, especially in the case of constructions crossing several parcels, would be improved considerably, if the actual location of physical objects would be available in the registration. With this information ‘gaps’ as in the case of 3D right-volumes could be avoided. A possible solution to have the spatial extent of a whole physical object in the cadastral registration could be to register one volume parcel enclosing the legal space of the physical object, which is actually the combined 2D/3D alternative of a full 3D cadastre (see next section). However, a solution that fits within the current juridical framework, is the registration of the complete construction (tunnel, pipeline) itself with a spatial description of the object. The registration of physical objects is independent from the question of whether there have been rights established and registered on the intersecting parcels. The physical objects are added for the same purpose in the cadastral geographical data set as buildings: to link cadastral registration with representations of reality (i.e. topography) for orientation and reference purposes. A physical object is a construction above or below the surface which may cross parcel boundaries. In the case of physical objects, the objects themselves are registered and not the 3D legal space (as in the first alternative). The legal space is the space to which the holder of a physical object wants to have a right to ensure the property of the object, which is usually larger than the physical extent of the object itself (for example including a safety zone). In general the holder of a 3D physical object is the person or organisation who is responsible for the 3D physical object. He has an economic ownership of the construction (right of exploitation) and benefits from the construction but also pays the costs for maintenance and replacements. The main objective of the registration of physical objects is to reflect the construction itself. This information can be then used to examine the legal status of the situation.

The registration of physical objects can be compared with the registration of telecom-networks in the Netherlands (since June 2003). A centre-line of the network (possibly with information on a zone indicating the accuracy or the width of the network) is offered for registration at the Kadaster (in 2D and thus it is not clear if the network is located above or below the surface). The network is registered in the land registration using a drawing of the situation and in the cadastral registration using one or several anchor parcel(s) while a legal notification for all intersecting parcels can be registered voluntarily. At this moment the spatial information on the network is not added in the cadastral geographical data set. Therefore, the user still has to consult the legal document and the drawing archived in the land registration. If the spatial information of networks would be available in the cadastral registration, the networks could be used for orientation. Registration of legal notifications on all intersecting parcels would no longer be necessary.

A registration of 3D physical objects needs to be organised and maintained and this registration will become a cadastral task. For the implementation of this registration

either a finite list of objects that need to be registered has to be made or the registration could be voluntary, as is currently the case for telecom-networks based on the idea that such a registration offers benefits for the holders of 3D physical objects. In the cadastral registration spatial as well as non-spatial information on the whole 3D physical object is maintained. This information could be maintained directly, but preferably via the GII by which the information on physical objects can remain at their source (see section 5.3). A 3D physical object can be queried as a whole. For example, which parcels are intersecting with (the projection of) a 3D physical object (this is a spatial query)? Which rights are established on these parcels? Who are the associated persons?

The solution of registering 3D physical objects (including geometry in 3D) meets the need of a 3D cadastre to register constructions themselves, or at least to have the location of physical objects available in the cadastral registration (and included in the cadastral map). A 3D description of physical objects can be used if the cadastral map is available in 2.5D. A limited right still needs to be established on the intersecting parcels referring to the physical object to explicitly secure the legal status (the 2D parcel is still the basic entrance for establishing real rights and for the cadastral registration), but the parcels do not need to be divided into smaller parcels, since the exact location is known in the registration. In addition the information on the physical object needs only to be maintained once, instead of with every intersecting parcel. Since the physical objects are integrated in the cadastral geographical data set, the real situation is much better reflected than in the current cadastral registration. For the registration of 3D physical objects the UML class diagram in figure 10.5 applies.

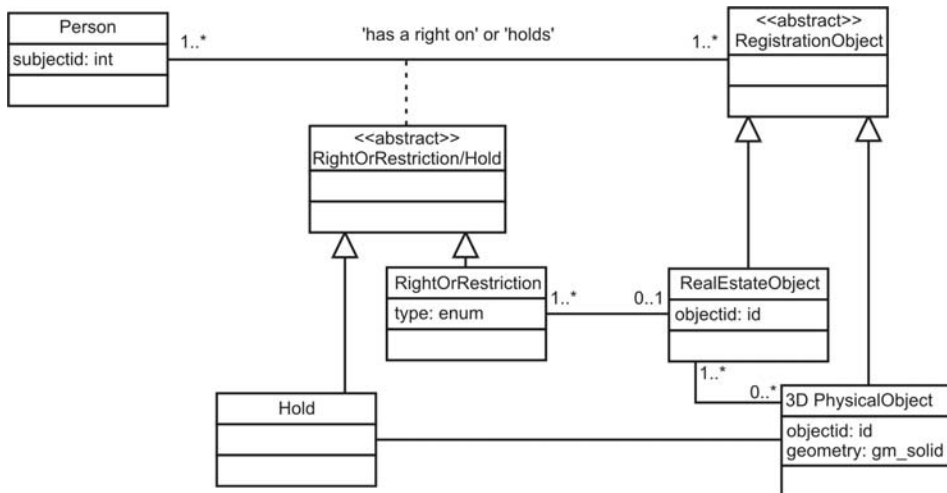

Figure 10.5: UML class diagram of 3D physical objects.

Apart from parcels (real estate objects), 3D physical objects are also registration objects. Rights and limited rights are still registered on real estate objects (2D parcels in this case). The only right that a person can get on a 3D physical object is that he can become the holder of this object (or an owner dictated by Public Law as in

the case of telecom-networks, and in the future possibly also in the case of gas and electricity networks, see section 2.4.1). A 3D physical object is not a specialisation of real estate objects: 3D physical objects are maintained in addition to parcels and parcels are still the basic entity of registration.

A basic complication that is not met by either solution is that a 2D parcel is still the base for registration, implying that the legal status of constructions cannot directly be established and not directly be registered on the construction or volume itself. Surface parcels (defined in 2D or 2.5D) are still always needed to ensure the legal status in 3D.

## 10.4 A full 3D cadastre

To meet the cadastral needs at a more fundamental level, the concept of 2D parcel should be reconsidered as well as the changing role of cadastral registration. As was seen in chapter 1, nowadays, cadastral registration not only focuses on the registration of ownership of real estate, but also serves other tasks (used by both private and public sectors in land development, urban and rural planning, land management and environmental monitoring). In the full 3D cadastre the concept of 2D parcels as (only) basis for registration is abandoned. The registration object in the full 3D cadastre gets a wider meaning. It may include areas or volumes, not necessarily coinciding with (3D) ownership boundaries of land, e.g. a forest protection zone. This is similar to the term ‘legal land object’ as defined in [54] and ‘RealEstateObject’ in [101].

In the full 3D cadastre, rights are no longer established on parcels, but on well-defined, surveyed volumes. This is the basic difference from the hybrid solution, which still holds to a 2D (but implicit 3D) registration. For the full 3D cadastre, two alternatives are distinguished: 1) a 3D cadastre in which a 3D real estate object is either an infinite parcel column, defined by a surface parcel, or a volume parcel and 2) a real estate object is always defined as a bounded volume parcel.

### 10.4.1 Combined 2D/3D alternative

The combined 2D/3D alternative starts with the currently registered parcels, which are converted into infinite parcel columns. In addition to infinite parcel columns, volume parcels are distinguished.

In this solution, the real estate objects can be:

- parcels, representing either infinite parcel columns, or columns of space of which volume parcels have been subtracted: these parcels are actually defined in 3D (based on the 2.5D surface representation);
- volume parcels;
- restriction areas (only defined in 2D);
- restriction volumes (defined in 3D).

The UML class diagram of this solution is shown in figure 10.6 (see also [101]). In a full 3D cadastral registration, implemented according to this model, an instance

of a parcel always exists which is the basis of the cadastral registration. A volume parcel is only established if a bounded space is subtracted from a parcel column defined by the boundaries on the surface. Consequently, in the fictive case in which no stratified properties exist, this full 3D cadastre would only contain infinite parcel columns defined by boundaries on the surface which form a full 2.5D partition.

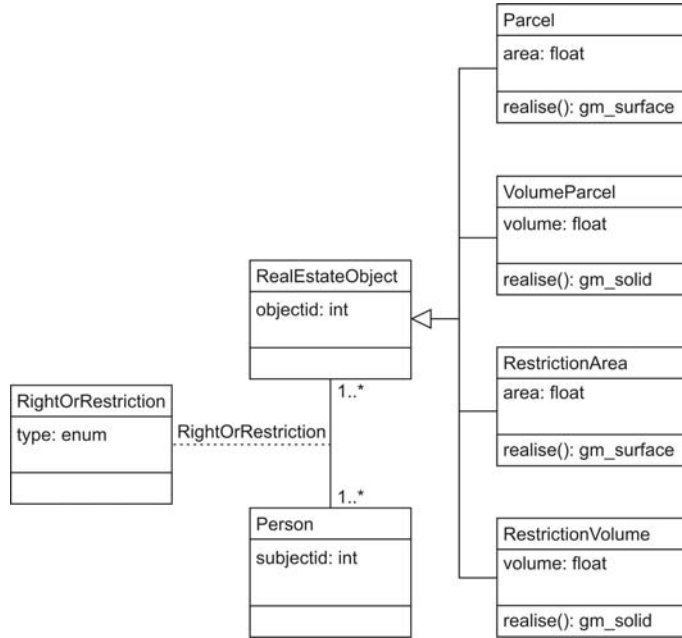

Figure 10.6: *UML class diagram of full 3D cadastre that supports both infinite parcel columns and volume parcels. The parcel objects are part of a 2.5D partition.*

The collection of the 2.5D surfaces of parcels (parcels draped over a height surface) explicitly covers the whole surface (without overlaps and gaps). This is a very important concept in cadastral registration in order to avoid inconsistencies. A ‘Parcel’ implies the whole 3D column above and below the surface or what is left after volume parcels have been subtracted from the parcel column. The geometry of the volume parcel defines a bounded space in 3D. Consequently a complete space partition is defined by the (infinite) parcel columns and the volume parcels. One volume parcel can be established crossing several parcels.

Important constraints for the full 3D cadastre are:

- Projection of parcels should form a full partition of the 2.5D earth surface.
- Volume parcels may not intersect other volume parcels in 3D.

Because of the different meaning of restriction areas and restriction volumes, restriction areas may intersect other restriction areas (e.g. a forest protection zone may intersect a ground water protection zone), and restriction volumes may intersect other restriction volumes. For example a 3D volume that indicates severe soil pollution may

intersect with a volume that indicates the presence of a monument imposed by the Law on Monuments.

To be able to register the parcels, volume parcels, restriction areas and restriction volumes in the cadastral registration, all real estate objects must have a survey document, which should make clear what space the real estate object refers to. The 3D information in these survey documents can then be integrated in the cadastral geographical data set, which will be a mix of 2.5D objects (surface parcels and restriction areas) and 3D objects.

### 10.4.2 Pure 3D cadastre

In the pure 3D cadastre that only supports volume parcels, the concept of 2D parcels (or infinite parcels that are defined by parcel boundaries on the surface) is totally abandoned (see figure 10.7). It is no longer possible to establish an ownership right on an infinite parcel column defined by boundaries on the surface.

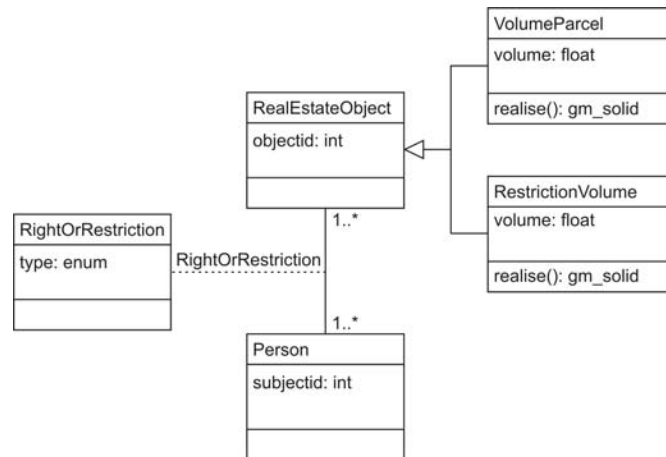

Figure 10.7: *UML class diagram of a full 3D cadastre that only supports volume parcels. The volume parcels are part of a space partition.*

Property rights to real estate objects can only be related to volume parcels that are fully defined and bounded in 3D. Consequently open (unbounded) parcels do not exist. The volume parcels, that are the basis for registration, form a full partition of 3D space without gaps or overlaps. This requires a change in the juridical framework since ownership does no longer reach as high or as low as a user has possibly interest, but should always be explicitly limited in height and depth. When starting such a cadastre, one could think of limiting the already registered ownership of parcels in height and depth, e.g. reaching from 100 meter below the surface to 500 meter above the surface.

In addition to volume parcels, restriction volumes are registered that may intersect volume parcels as in the combined 2D/3D alternative. Every limited right and re-



striction that is established and registered in the cadastral registration should be accompanied with a 3D spatial description defined in a 3D survey document. The cadastral map is fully 3D since it only contains volumetric objects (volume parcels bounded with 3D boundaries).

In this solution cadastral registration of the whole country is converted into 3D.

## 10.5 Evaluating the conceptual models

In this section the proposed solution will be considered, both from a Dutch cadastral point of view (section 10.5.1) and a technical point of view (section 10.5.2). Section 10.5.3 will conclude on the optimal solution for a 3D cadastre.

### 10.5.1 Solutions seen from a cadastral point of view

#### **Cadastral objectives**

As was concluded in part I of this thesis the main objective of cadastral registration is to warrant legal security in real estate (transactions). This means that stratified property has to be registered in a correct way and that the registration should provide insight into the actual (legal) situation in a simple, straightforward and sustainable manner (i.e. the cadastre should support optimal accessibility and maintainability). At this moment the accessibility of the registration in 3D situations is poor. At first sight even the professional user (notary, real-estate agent or cadastral employee) may not be aware of or completely understand the 3D situation, let alone the public at large and the non-cadastral specialists (e.g. planners and contractors). The better the accessibility of the registration in complex 3D situations, the better the legal security of the real estate is warranted. The main objective of a 3D cadastre focuses therefore basically on improving the information which is available in the cadastral registration in 3D situations (see also chapter 5).

#### **Cadastral considerations on proposed solutions**

A full 3D approach would solve a lot of problems: the basic entity of a cadastre is no longer a 2D parcel, by which all 3D situations have to be projected on a 2D cadastral map, but a volume. This offers better possibilities to reflect the real situation, since rights to real estate always have been related to a volume and not to just an area. However the full 3D approach results in a renewal of the cadastral registration in which the concepts of rights in 3D and of the right of ownership need to be reconsidered. Within the current juridical framework it is already possible to establish stratified property (3D property units), however within this framework the ownership of real estate is still land (surface) oriented.

In the first alternative of the full 3D cadastre (combination of infinite parcel columns and volume parcels) the new concept of the right of ownership of a parcel could include all space above and under the surface with possibly volumes subtracted to which other persons are entitled with a right of ownership. The question whether the juridical framework can simply adopt this concept, without any complication, is dependent on the background of the specific cadastre. As was seen in chapter 4, some

countries have already introduced the concept of multilevel ownership. However, in the Netherlands, the introduction of legal space that is no longer related to surface parcels may cause some more complications.

The approach where 3D situations are stored in the 2D cadastre (hybrid solution) is advantageous from the point of view of accessibility, compared to the current situation. Both the 2D and 3D information are directly available and can be integrated, while this solution requires only minor changes in cadastral registration (and only in 3D situations) and no changes in the juridical framework. The legal status of real estate is still strongly related to 2D land parcels, and not to 3D volumes, as in the full 3D cadastre approach.

The approach with external references to 3D situations is followed at the moment, apart from the fact that 3D situations are not stored in the cadastral database as so-called ‘local’ files, but separately on paper (and recently on scanned) drawings. This registration has proved to be practical with apartment rights and could be improved by the inclusion of digital 3D drawings in the cadastral database. Also making the digital (scanned) deeds, including drawings, accessible through the cadastral database, will improve accessibility of information in 3D situations. Given the current cadastral data model this option is a good starting point, but not a sustainable option for the future. The basic disadvantage is that the spatial and non-spatial information of the 3D property situation cannot be integrated with the cadastral registration.

### 10.5.2 Solutions seen from a technical point of view

When looking at the solutions from a technical point of view the basic questions are how to support 3D spatial features in the current cadastral geo-DBMS, how to access this spatial information by all kinds of front-ends and how to represent parcel boundaries in 2.5D. The answers to these questions depend on technological possibilities and developments.

This subsection starts with a description of the optimal technical environment of a 3D cadastre followed by a description of the state-of-the-art summarised from chapter 7, chapter 8 and chapter 9. Based on these two aspects the technical perspective on the proposed solutions is given.

#### **Technical implementation of a 3D cadastre: the optimal solution**

The integrated architecture in which geometrical and topological information as well as administrative information on objects are stored and maintained in one integrated geo-DBMS should be the starting point for a 3D cadastre, since this offers best maintenance (consistency, integrity) possibilities.

An ideal case would be to have spatial information on all objects relevant to the cadastre (physical objects, objects representing legal space and height surfaces of parcels) in 3D space available in the database. The support of 2D, 2.5D and 3D data types in the DBMS will offer the integrated storage of spatial data within the DBMS and spatial functions in 2D and 3D at SQL level in order to keep a consistent data set. The support of spatial data in a geo-DBMS includes: spatial data types (geometry and topology), spatial operators (or functions), spatial indexing and clustering and topological structure management of both planar and volumetric partition. All the

spatial information that is maintained in DBMSs should be accessible by all kinds of front-ends (GIS, CAD, Web based front-ends).

#### **Technical implementation of a 3D cadastre: the state-of-the-art**

As can be concluded from chapter 7 mainstream geo-DBMSs have implemented spatial data types and spatial functions more or less similar to the OpenGIS Simple Features Specification for SQL. However, these implementations are basically 2D, with the possibility to store 3D coordinates, and mainly focus on the geometrical primitive. OGC still works on extending the Simple Feature Specification for SQL to support topological structure and 3D geo-objects.

In the area of topology many concepts have been developed (both for 2D and 3D). However extensive 2D topology structure management (partitions and linear networks) have only recently become available within some DBMSs. Therefore it is still difficult to update geometry in DBMSs, because of the risk of inconsistencies. Standard support for 3D topology will still take years. In the mean time, the topology structure could be supported at application level while storing the results in the DBMS.

Although 3D geometrical primitives and 3D topological structure is not (yet) available within mainstream DBMSs, chapter 7 proved the potentials of user-defined solutions. Chapter 8 showed that the user-defined solutions could also be accessed by several types of front-ends, although 3D GIS functionalities in general still need to mature.

Initially steps to maintain an effective integrated height and parcel model in the DBMS were taken in this research and showed already potentials in chapter 9, although the integrated model still needs further improvements.

Apart from the modelling aspects, also the collection and insertion of 3D information should be considered as well as the conversion from 2D parcels to 2.5D representations of parcels. Although it is becoming easier to collect data in 3D (by means of video, laser scanning and GPS), it will take a lot of effort to collect all data needed for registering 3D situations. Collecting information on physical objects could benefit from automatic object reconstruction techniques, although complete automatic reconstruction implementations do not yet exist (see section 8.1). On the other hand, the 3D objects of interest to the cadastre do not always (per se) relate to physical objects, e.g. a volume to which a right applies does not correspond completely with the 3D extent of the physical object, because also a safety zone may be included (which might require a buffer operation in 3D). It may be difficult to survey such a situation. The use of CAD designs to represent 3D geo-objects also needs further research.

#### **Technical considerations on proposed solutions**

A full 3D cadastre is comprehensive from a technical point of view. It requires the integration of 3D surveyed data in a 3D topological structure (initially defined by parcel columns). Implementations for full 3D support in DBMS (geometry as well as topology) have just started and do not yet exist. A full 3D cadastre will therefore be dependent on user-defined implementations, which will not necessarily be a problem, as we have learned from experiences with the Dutch cadastral database in which both history and topology are maintained successfully, although not supported at DBMS level [136]. In addition, the Dutch cadastral database already maintained spatial data, even before the DBMS vendors started with support for spatial data types.

The combined 2D/3D alternative of a full 3D cadastre is less complex than the pure 3D cadastre alternative, since a full volume partition is not needed. The collection of 3D data when the parcel *is* bounded will take considerably more effort than in the traditional 2D case, in which only the 2D boundary needs to be surveyed. The content of the current cadastral database containing 2D parcels boundaries is the result of surveying that has been carried out since the beginning of the nineteenth century. The collection of bounded parcel geometries in 3D has to begin from scratch. Consequently it may take years until a serious 3D cadastral database is reality. The integrated view based on 2D parcel boundaries and point heights is needed in the combined 2D/3D alternative of a full 3D cadastre. Chapter 9 showed the potentials for this integrated model, but it also showed that such an integrated view still needs further development.

The hybrid solution, with the current 2D cadastre as starting point (with infinite parcel columns defined with boundaries on the surface) and an extension to register 3D situations seems a feasible solution for the medium-term future. 2D spatial objects are supported in DBMSs and 2D data are available in large amounts and are often still sufficient. The implementation of an extension to maintain 3D spatial features, having also non-spatial attributes, seems possible as well as the possibility to maintain a 2.5D surface of parcels. Also the hybrid solution does not need a full volume partition of space. The implementation of the hybrid cadastre will be based on techniques available to represent 3D spatial features and on new developments based on research.

The 2D classical registration with tags to 3D situations is current practice in the Netherlands but seems no sustainable solution for the future. The database contains references to paper or digital drawings (or files), instead of integrating the 3D situation as 3D spatial features in the 2D geo-DBMS. The technical problem of this solution is that the DBMS cannot guarantee consistency (do two 3D situations overlap?), nor can the 3D situation be queried in a combined environment with 2D parcels or other 3D situations.

### 10.5.3 The optimal solution for a 3D cadastre

As can be concluded from above, the option ‘3D tags in the current cadastral registration’ is a solution which works, as current practise proves, however it has some basic limitations. The solution cannot provide one 3D overview of a cadastral map integrated with 3D property situations: 3D situations can only be examined per parcel, i.e. isolated from each other. This solution does therefore not give a base for efficient and sustainable registration in the future.

A full 3D cadastre offers solutions on the basic concept of the cadastre. With this solution ownership boundaries in 3D can be established and division of ownership in all directions can be defined and registered in the cadastral registration. However, the question can be posed whether a full 3D cadastre that only supports volume parcels (pure 3D cadastre alternative) is realistic for cadastral registrations that have a long history and already contain a lot of information that is related to 2D parcels. In addition, the 2D parcels still suffice in many cases. Technologically it is possible to convert the unbounded parcel columns into bounded volumes, however this conversion may meet a lot of complications within the juridical and cadastral frameworks. The

pure 3D cadastre alternative requires a total renewal of the cadastre, also in 2D situations, while the first alternative of a full 3D cadastre still has a strong link with current cadastral registration: traditional 2D situations (parcels with only one person entitled to it) can be kept largely unchanged. From a practical point of view, a 3D cadastre is mostly needed in densely built-up areas. For most of the country, however, a ‘classical’ 2D cadastre based on 2D parcels serves its purpose well. Therefore the pure 3D cadastre alternative is not seen as a feasible solution. The combined 2D/3D alternative of a full 3D cadastre offers the best opportunities to solve the complications of current 3D registration. Therefore the combined 2D/3D concept of a full 3D cadastre will be the aim of this research.

Although the combined 2D/3D concept of a full 3D cadastre is the final stage where most problems of 3D registration are solved and although this solution has already shown potentials in some countries and states (Norway, Sweden, Queensland, British Columbia), it might take some time before this concept can be adopted in juridical frameworks in other countries, as in the Netherlands. The concept reconsiders the basics of cadastral registration: the concept of 2D parcels is abandoned since in a full 3D cadastre it is possible to bound the ownership of real estate in the third dimension while the ownership of real estate is no longer (always) related to surface parcels.

Therefore we will also focus on a feasible solution for the Dutch 3D cadastre for the medium-term future. This solution should fit within the current juridical doctrine and with some minor adjustments within the cadastral and technical framework (changes in cadastral and technical framework should be achievable in the medium-term future). The hybrid solution shows potentials for the medium-term future. From a cadastral point of view the hybrid solution meets already the most important need of 3D cadastral registration, i.e. improve insight in 3D situations.

In conclusion, we will start with the implementation of a registration of 3D situations in the current cadastral registration, which is similar to the hybrid concept. Subsequently, we will also look at the implementation of a full 3D cadastre, which will not only meet the complications of cadastral registration in the medium-term future, but reconsiders the concept of the 2D parcel as basic cadastral entity.

## 10.6 Conclusions

In this chapter three solutions for a 3D cadastre were studied: a full 3D cadastre with two alternatives, a hybrid 3D cadastre with two alternatives and a cadastral registration that contains tags to 3D situations and links to 3D representations. The UML class diagrams for the proposed models were also given.

For the full 3D cadastre, the following two alternatives were introduced:

- a 3D cadastre that combines the registration of volume parcels with the registration of infinite parcel defined by parcel boundaries on the (2.5D) surface. The basic registration entities are infinitive parcels columns or original infinite parcel columns from which a volume parcel has been subtracted (parcels) and volume parcels;
- a 3D cadastre that only supports volume parcels. The volume parcels form a

full partition of space, without any gaps or overlaps.

The two alternatives to effectuate the hybrid approach are based on the fundamental needs for a 3D cadastre, i.e. to register the spatial extent of rights and to be able to reflect constructions themselves in the cadastral registration. The proposed concepts are: the registration of 3D right-volumes, in which the right that entitles a person to a volume is the starting point for registration, and the registration of 3D physical objects, in which the physical object is the starting point for registration. A 3D right-volume is a 3D description of a right (legal space) that has been established for a 3D situation. The 3D description covers the complete 2D parcel with limitations in height and depth by horizontal planes. This 3D description is integrated in the cadastral map. The user can see that something is located above or below the surface including the (approximate) location. Precise information can be obtained from deeds and survey plans archived in the land registration. Registration of 3D right-volumes requires only little adjustment in the current cadastre, although this registration may lead to gaps in the visualisation of the 3D situation. The gaps occur since only 3D right-volumes are registered when the 3D situation has led to a cadastral recording. Other cases are for example cases of not-registered personal rights (short lease) or obligations to tolerate constructions for public good that follow from general laws. The gaps are solved by a registration of physical objects. The registration of physical objects maintains physical objects above or below the surface which mostly cross parcel boundaries. The spatial extent of physical objects is integrated in the cadastral geographical data set, or accessed via the Geo-Information Infrastructure, by which it is possible to use this information to support the cadastral tasks.

The proposed solutions were considered both from a cadastral point of view and a technical point of view. Based on these considerations, the full 3D cadastre approach was selected as the most optimal solution. The second alternative (the full 3D space partitioning) seems less realistic since it requires a total renewal of cadastral registration while 2D parcels still suffice in many cases. Therefore the first alternative is selected as the conceptual model that meets the registration of 3D situations in the most optimal way, seen from the juridical, the cadastral and the technical point of view. Technology developments have progressed in such a way that it is realistic to study the possibilities of maintaining and accessing 3D geometrical primitives in a DBMS and to maintain a 2.5D representation of parcels.

The full 3D cadastre is a step too far for the near and medium-term future for some cadastral registrations, since the juridical framework needs to be adjusted which will meet complications. It requires a reconsideration of the basic concept of cadastral registration: cadastral registration is no longer focused on land but on volumes. Therefore the hybrid approach is also further considered in this thesis. The hybrid approach fits, to some extent, within the current Dutch juridical and cadastral framework.

The remainder of this thesis will focus on the proposed solutions that show best potentials: the first alternative of a full 3D cadastre and both alternatives of the hybrid solution. The selected alternatives will be assessed on both the concepts, the implications and the implementations, to come to optimal recommendations for a 3D cadastre.

# Chapter 11

## Logical model for a 3D cadastre

In chapter 10, the conceptual models for several alternatives for a 3D cadastre were described and evaluated. The alternative that showed best potentials is the full 3D cadastre in which parcel registration (where parcels imply an infinite parcel column or what is left after subtracting the intersecting volume parcel(s)), is combined with the registration of volume parcels. However the implementation of this concept of a full 3D cadastre might be very complicated in some cadastral registrations due to the required changes in legislation. Therefore the hybrid solution is also further considered in this thesis. The hybrid solution, in which 3D situations are registered in addition to 2D parcels in order to improve insight in the 3D situation, showed best potentials for a cadastral registration that is still land (surface) oriented. This solution was translated into two alternatives: the registration of 3D right-volumes and the registration of 3D physical objects.

In order to be able to store and maintain all data which is required to effectuate the conceptual data models in a DBMS, the next step after the design of the conceptual models, is the translation of the conceptual models into a logical model, i.e. database structures. To actually effectuate the 3D cadastre the logical model can be populated with instances (data).

In chapter 6, the object relational model was selected as the most appropriate database model for the 3D cadastre implementation. In this chapter considerations are described that have to be taken into account when the conceptual models of 3D right-volumes, 3D physical objects and the selected alternative of the full 3D cadastre are translated into an object relational database structure (section 11.1, 11.2 and 11.3). Section 11.4 describes the 4D aspects of the logical models of the three selected alternatives: how to maintain history in a 3D cadastre.

The chapter ends with concluding remarks.

## 11.1 3D right-volumes in the DBMS

This section describes considerations for the two main parts of the logical model for 3D right-volumes: the spatial data model (section 11.1.1) and the administrative data model (section 11.1.2). The data models will be populated with data obtained with data collection techniques. Considerations for spatial data collection for 3D right-volumes are described in section 11.1.3.

The implemented logical model makes it possible to perform queries that are required to meet the need for a 3D cadastre. In section 11.1.4 the queries are described that are possible when 3D right-volumes are maintained.

### 11.1.1 Spatial data model

The 3D description of 3D right-volumes initially starts with parcel boundaries in 2D. Parcel boundaries are extended into the vertical dimension using the upper and lower limits of rights. This spatial definition of 3D right-volumes results in 3D volumetric features bounded with flat faces. The height-levels are initially invariant for every 3D right-volume (upper and lower boundaries of 3D right-volumes are defined by horizontal planes). It should be noticed once again, that the representation of one z-value per upper or lower boundary is restrictive, especially when the terrain itself has relief.

To implement the spatial data model of this concept, a table was introduced (3D right-volume table) that contains for every parcel the different height-levels of properties piled on one parcel (z-list). The z-list contains n z-values corresponding to n-1 consecutive ranges associated with the parcel. The z-values should be preferably defined in absolute values. However, in the case studies only absolute z-values were used where they were available, in the other cases relative z-values were used. The z-values are stored as an Abstract Data Type (array).

Because of the simple definition of 3D right-volumes, 3D right-volumes within one parcel could overlap which does not correctly reflect the real situation. This could be solved in some cases, by subdividing parcels in such a way that the overlap of 3D right-volumes within one parcel is solved (see figure 11.1). However, this subdivision does not work in all cases, e.g. where the two sloping levels touch. In addition, the question can be posed if this is a feasible solution to this problem.

As was seen in chapter 10, only positive right-volumes will be registered. Therefore the remainder of parcel columns will not be registered with 3D right-volumes. For example, when a tunnel intersects a parcel that is owned by a private person and a right of superficies has been established on the parcel to hold the tunnel, only one 3D right-volume is registered referring to the right established for the tunnel and no 3D right-volume referring to the upper and lower 'open' space. More in general this means that a 3D right-volume for the bare owner (person who holds the ownership that is encumbered with limited real rights) will not be registered. The space to which the bare owner is entitled can be found by subtracting all positive right-volumes that have been registered above and below the parcel. It is possible that the space that is left for the bare owner may also include space between two 3D right-volumes, e.g.



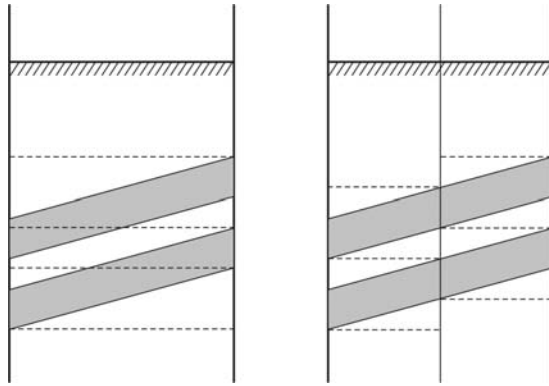

Figure 11.1: *Subdivision of parcels (right) may solve the problem of two overlapping 3D right-volumes within one parcel (left).*

when a tunnel would be drilled below The Hague Central Station (see section 3.1.2) and a right of superficies would be established for the tunnel. The holder of the railway platforms (in this case the bare owner of the parcel) would in that case own the space between the right-volume of the bus and tram station and the right-volume of the tunnel. Since the 3D right-volumes are defined with a list of z-values, this space in-between is also included in the z-list.

### Geometry

The z-list is sufficient to generate the representation of 3D right-volumes based on the realised geometry of parcel boundaries. 3D (volumetric) data types are future work for DBMSs. Still the advantages of current techniques can be used. The polyhedron approach as it is currently available in the DBMS is appropriate for defining 3D right-volumes since the geometry of polyhedrons is similar to the way 3D right-volumes are spatially defined (existing of flat faces). A 3D right-volume is built by starting with the list of coordinates of the whole parcel ring. A vertical face is generated between every two coordinates, using the upper and lower limits of the right. The 3D right-volume is closed by two horizontal faces: one on top and one below.

Based on the 3D right-volume table containing the z-list, and the parcel boundaries a 3D geometrical representation of the right-volumes can be generated in three ways (the first two are available within current techniques, and the last one is the self-implemented solution):

- define a 3D right-volume as a set of polygons defined in 3D, this is partly a topological solution, since faces can be shared (see section 7.1.2);
- define a 3D right-volume as one multipolygon defined in 3D (see section 7.1.2);
- using the 3D geometrical primitive that was implemented as part of this research (this geometrical primitive supports internal topology, see section 7.4).

All these 3D representations consist conceptually of polyhedrons. In the prototype the topological structure of 3D right-volumes is stored and a function has been written that generates the geometrical description of 3D right-volumes using these geometrical

primitives. The geometry of 3D right-volumes can be made available with a view. In the prototypes the multipolygon representation is used as basic geometrical model since CAD and GIS front-ends recognise a multipolygon as one 3D object.

### **Topology**

The spatial model of 3D right-volumes should support topological structure within one parcel, which mean that faces, edges and nodes are shared within one parcel. In a more advanced implementation of 3D right-volumes one could think of sharing nodes and faces between right-volumes that are established on neighbouring parcels. This makes it possible to query neighbours of 3D right-volumes on top of each other using explicit topological structure, which is more efficient than performing this topological query on geometry (as was seen in chapter 7). In addition since stratified 3D right-volumes share the in-between faces, data consistency is assured, e.g. two 3D right-volumes on one parcel cannot overlap or during updates when a 3D boundary (3D face) is moved.

Current geo-DBMSs do not support topological structure in 3D. Therefore the user-defined model as described in section 7.2.4 is used in the prototype implementations to implement topological structure for 3D right-volumes.

A function in the prototype implements the topological structure of 3D right volumes within one parcel, based on the z-list and the realised geometry of parcel boundaries. This implementation could be improved by storing only the z-list and making the topology structure of 3D right-volumes available with a view.

## **11.1.2 Administrative data model**

In Dutch Civil Law persons are entitled to 3D right-volumes by means of limited rights. This right is established on a parcel and associated with the 3D right-volume. Persons entitled to a 3D right-volume can be found by the right to which the 3D right-volume is associated (e.g. a right of superficies). The right-owner of this right is the person that is entitled to the 3D right-volume. The full ownership of a parcel as well as the ownership of a parcel that remains after limited real rights have been established on the parcel is never related to 3D right-volumes because ‘negative’ right-volumes are not registered. In the case of 3D right-volumes four cases can be distinguished:

- The person using space above or below the surface is the full owner of the surface parcel(s). No 3D right-volume can be registered, since no limited rights are established.
- The person who holds a construction above or below the surface is the bare owner of the surface parcel(s): other persons are entitled to the space above and below the construction by means of limited rights, such as right of superficies, right of long lease, right of easement etc. 3D right-volumes (related to third parties) are registered for space above and below the construction but not for the bare owner of the parcel who is the holder of the construction.
- The person who holds a construction (e.g. tunnel) is entitled to space above or below the surface by limited rights on the parcel, such as right of superficies or a right according to Public Law. A 3D right-volume will be registered for the space related to the construction. This is the case in figure 12.7.

- The person using space above or below the surface is not the owner of the surface parcel and has no rights on the parcel: the legal status of the space used is not explicitly registered.

### Attributes

The person that is entitled to the 3D right-volume with a right is important, as well as the type of right that entitles the person to that 3D right-volume. This information can be accessed via a view on the AKR tables. Both the list of persons and the list of types of rights are presented as Abstract Data Types (arrays) in the 3D right-volume table, because the number of persons that are entitled to parcels can vary. This would result in multi-column or multi-row representations to list the persons and rights that are related to one parcel in a full relational implementation. Using ADTs enables to use a one-column structure for the list of persons as well as for the list of rights.

Whole 3D real estate objects are also maintained, with their id's. The 3D right-volumes contain a reference to the id of the real estate object of which they are a part, by which it is possible to obtain a list of all 3D right-volumes that refer to the same 3D real estate object. Spatial information on the whole 3D real estate object could be maintained, as well as non-spatial information on the whole real estate object (function, holder). 3D right-volumes are identified by unique numbers. The numbering is done in such a way that 3D right-volumes are related to the affected parcel. The numbering could be done similar to the numbering of apartments. For example on a ground parcels 1234, two 3D right-volumes are generated, one ranging from -20 to 0 to hold a tunnel and one from 0 to 13 to hold a building on top of the tunnel. The 3D right-volumes could be numbered 1234 RV1 and 1234 RV2. The RV refers to a 3D right-volume.

In general the table (or view) containing the information on 3D right-volumes, must have (at least) the following columns:

- id: id of the 3D right-volume;
- type\_of\_right: the type of right that is associated with the 3D right-volume, this information comes from AKR via the association to 'RightOrRestriction';
- subject: person that is entitled to the 3D right-volume, this information also comes from AKR via two associations: firstly to RightOrRestriction and secondly to Person;
- geometry: the 3D geometry of a 3D right-volume of type polyhedron, the geometry is defined with a spatial function on the topological structure;
- id\_real\_estate\_object: the id of the whole real estate object where the 3D right-volume is a part of (a registration of these real estate objects should be started);
- tmin: the start time of the 3D right-volume (see section 11.4);
- tmax: the end time of the 3D right-volume (see section 11.4).

### Relationships between parcels and 3D right-volumes

Juridical relationships between 3D right-volumes and parcels exist via the limited rights, apartment rights and restrictions. A limited right, an apartment right or a restriction is established on a parcel and is associated with a 3D right-volume. The possible relationships between 3D right-volumes and parcels are m:1. Several 3D right-volumes can be stacked on one parcel, while a 3D right-volume cannot cross

parcel boundaries, i.e. a 3D right object belongs to exactly one parcel. The relationship between 3D right-volumes and parcels is explicitly maintained via the different associations (association to RightOrRestriction and association to Parcel).

Since 3D right-volumes are related to surface parcel, a subdivision of a parcel that contains a 3D right-volume will cause a subdivision of the 3D right-volume. This is a weak point in the concept of 3D right-volumes, since the pattern of 3D right-volumes is very much influenced by the surface configuration but also by what happens with the parcels on the surface (e.g. in case of a transfer of the surface parcel or in case of a subdivision).

### 11.1.3 Data collection

Since geometry of 3D right-volumes is relatively simple (compared to the geometry of 3D physical objects and the geometry of 3D parcels as in the full 3D cadastre case), data collection is not very complicated. For the 3D description of 3D right-volumes the only information needed is the lower and upper level of the space to which the right applies. The issue of how to express the z-value (using absolute or relative values) was addressed in chapter 9. The height and depth of right-volumes are precisely defined in deeds and survey plans (preferably using absolute values, possibly combined with relative values). The deed can also contain a more precise definition of the space where the right refers to, e.g. using a drawing or 3D survey plan. The 3D description in the deed is not necessarily the same as the factual boundary of the construction. For example, the right of superficies established for the tram/bus station as part of the building complex of The Hague Central Station (section 3.1.2) can be defined just for the construction of the bus/tram station. However, it is also possible to establish a right of superficies that is higher than the bus/tram station, in view of future expanding on top of the bus/tram station by the municipality of The Hague.

### 11.1.4 Querying

The main improvement that the registration of 3D right-volumes will provide is the insight into the vertical dimension of rights. The queries that will be possible in the registration of 3D right-volumes are:

- Is someone else entitled to space below (or above) my parcel?
- Who is the owner of the construction below my parcel?
- Who is the owner of this space?
- What is the distribution of properties in 3D, i.e. show the 3D cadastral map of the situation?
- What is the spatial extent (both in 2D and in 3D) of this right of superficies?
- Who is the owner of the right-volume above/next to this right-volume ?

These queries can be performed when 3D right-volumes are registered. In the prototype implementation the topological structure of 3D right-volumes belonging to one

parcel is implemented. Therefore the query to find the 3D right-volumes on top of another can be performed on the topological structure.

The query to find neighbours next to each other needs to be performed on the geometrical primitives. Another possibility to find next-to neighbouring 3D right-volumes is to use the 2D cadastral geographical data set since 3D right-volumes coincide with parcel boundaries (which 3D right-volumes are established on the neighbouring parcel and at what level?).

## 11.2 3D physical objects in the DBMS

This section describes considerations for the spatial model (section 11.2.1), for the administrative model (section 11.2.2) and for data collection in case of a registration of 3D physical objects (section 11.2.3). CAD models are important sources for data collection in case of a 3D physical object registration, as will be seen in this section. Therefore this section also includes a discussion on how to link CAD with GIS (section 11.2.4). Finally section 11.2.5 describes the queries that are supported in a registration of 3D physical objects.

The registration of physical objects primarily focuses on a registration of infrastructure objects (objects for public good). Therefore the considerations described in this section do not especially address aspects in case of property units within building complexes.

### 11.2.1 Spatial data model

A 3D description of a physical object consists of the outer boundary of the physical object. The 3D legal space of physical objects is not within the scope of this registration, but will be registered in the full 3D cadastre (see section 11.3). Preferably, the description of a physical object is provided and maintained by the organisation responsible for the object and accessible through the cadastral database within a Geo-Information Infrastructure.

#### **Geometry**

The 3D geometry of physical objects can be stored in the DBMS within current techniques by using primitives that are supported (with minor support for topology or only support for internal topology).

From chapter 7 can be concluded that current mainstream DBMSs only support 3D objects by using flat faces. This is a limitation in storing 3D information concerning 3D physical objects, which often have complex geometries. For example the tunnel in figure 12.8 has been created in MicroStation by using the centre-line (defined with  $x, y$ , and  $z$  coordinates) and using the cross section of the tunnel, which is a circle with a radius of 7.5 meter. The CAD software extrapolated the cross section along the length axis. To store this object in a DBMS, a conversion from the parametric description to a polyhedron representation is required, by which the quality of the 3D representation will decrease, while storage space will increase. A better option would

be to store the centre-line and the cross section in the DBMS, whereupon the DBMS can generate the 3D representation. This is similar to the way circles are currently stored in 2D in the DBMS. Circles are not specified as a polyline consisting of many coordinates, but as a specific type of line or curve, i.e. a circle defined with three points on the circumference. Since current geo-DBMSs only support 3D geometries that are rather simple, the geometry of complex geometries is not taken into account in the prototypes.

### **Topology**

A full topological structure in which relationships between 3D physical objects are maintained is not needed in a physical object registration, since the maintenance of 3D physical objects does not require a full partition of space. Therefore a limited support of topology (only within objects and not between objects) as implemented in the geometrical primitives will be sufficient for 3D physical objects.

Topological relationships between two arbitrary objects (2D or 3D) can be derived by means of geometrical functions available in DBMS and can be used in constraints (e.g. to avoid overlaps). When topological relationships between objects are ‘derived on-the-fly’ the accuracy of the data is very important (when are objects inside, touching, equal, overlapping?). This is complicated in 2D, but even more complicated in 3D.

## **11.2.2 Administrative data model**

3D physical objects are registered, together with associations to holders of these objects. The holder of a 3D physical object is the person who has an economic ownership to the construction (right of exploitation). He benefits from the construction but also pays the costs for maintenance and replacements. In the case of physical objects below/above the surface, four similar cases as in the case of 3D right-volumes can be distinguished:

- The holder of the object is the full owner of the surface parcel(s).
- The holder of the object is the bare owner of the surface parcel(s): other subjects have limited rights on intersecting parcels, such as right of superficies, right of long lease, right of easement, etc.
- The holder of the object is not the owner of the surface parcel. The holder has limited rights on the surface parcel, such as right of superficies or a right according to Public Law.
- The holder of the object is not the owner of the surface parcel and has no rights on the parcel: the legal status of the physical object is not explicitly registered.

These cases can vary for one physical object per intersecting parcel. The last case should be avoided or should be solved by other regulations (such as the Law on Telecommunications). However, when 3D physical objects are stored in the DBMS these ‘gaps’ (also shown in figure 3.11 in chapter 3) can be depicted. For the first case the possibility to register 3D situations is not necessary from a juridical point of view (the legal status of the space above/below the parcel is clear: the holder of the construction owns the whole parcel column). However, the information on the whole physical object might be needed for future or reference purposes (e.g. when the parcel

intersecting with the construction is sold without selling the construction). Since the existence of a 3D physical object is the basis for registration, 3D physical objects will also be registered when the holder of such an object holds the intersecting parcels in full ownership. Both the parcel and the 3D physical object at the specific location will be registered and cadastral registration will be able to reflect the real situation at the location.

### Attributes

The rights for physical objects are not established directly on a 3D physical object but on the intersecting parcels. In order to ease querying, these rights may refer to id's of the 3D physical object using primary and foreign keys. The set of rights that are associated with one physical object can also be found by finding the intersecting parcels of a construction and then find the rights established on these parcels of which the subject is the same as the holder of the construction.

In general the table containing the information of 3D physical objects, must have (at least) the following columns:

- id: id of the 3D physical object;
- subject: person that has a permit to exploit the physical object (accessible via association);
- geometry: the 3D geometry of a 3D physical object (which is explicitly stored);
- tmin: the start time of the 3D physical object;
- tmax: the end time of the 3D physical object.

The 3D physical object table could also contain a column with a list of all intersecting parcels. This list could be stored explicitly, but a better option would be to define this list in a view with a spatial function.

### Relationships between parcels and 3D physical objects

When 3D physical objects are spatially described in the DBMS, it is not necessary to describe the relationships between parcels and physical objects explicitly, since these implicit relationships (n:m) can be obtained through spatial functions available in the DBMS or by visualising all the spatial information in an integrated view. As a rule, when a physical object intersects with a parcel a juridical relationship shall be established. This rule could be implemented as a constraint in the DBMS. When a 3D physical object is inserted in the DBMS, it is checked if there are parcels intersecting with the 3D physical object with no rights established for the 3D physical object.

Via rights the possible (explicit) relationships between 3D physical objects on the one hand and parcels on the other hand are m:n.

Juridical relationships between a 3D physical object and the surface parcels exist through the holders of the 3D physical object who should be subjects of rights or restrictions on intersecting parcels. Via this route the possible relationships between 3D physical object and the surface parcels are also n:m.

### 11.2.3 Data collection

Spatial data models for 3D physical objects can be populated with data obtained by object reconstruction techniques. As was seen in section 8.1.2 the process of 3D object

construction still needs to be done partly manually and is therefore time-consuming. In addition underground constructions such as tunnels and pipelines cannot be captured using (aerial) laserscan and photogrammetric techniques. Therefore it is useful to have a look at other possible sources. Since 3D data is available with designers, mostly as CAD models, this data could be used to populate the spatial data models of 3D physical objects in the DBMS.

The next step is to study how CAD designs can be used and what selections and generalisations are needed to obtain the relevant information out of these designs such as the outer boundary of objects. As part of this research a municipality (Rotterdam), two departments of the Ministry of Transport and Public Works (*Bouwdienst van Rijkswaterstaat* and *Projectorganisatie HSL-zuid*), and a designer (*Holland Railconsult*) were visited to look for usable CAD models. Based on this survey the conclusion can be drawn that CAD models are not always created in the design process of 3D physical objects (and are therefore not available to be inserted into a 3D cadastre). Most tunnels are still designed on 2D drawings by using linear profiles and cross sections. Contractors and builders are used to the 2D drawings: understanding 3D drawings would require other skills and software. However this information could be a very good basis for deriving a 3D model for the 3D cadastre.

There are plenty of examples in which 3D CAD models are generated in the design process, but mainly for visualisation purposes (figure 11.2).

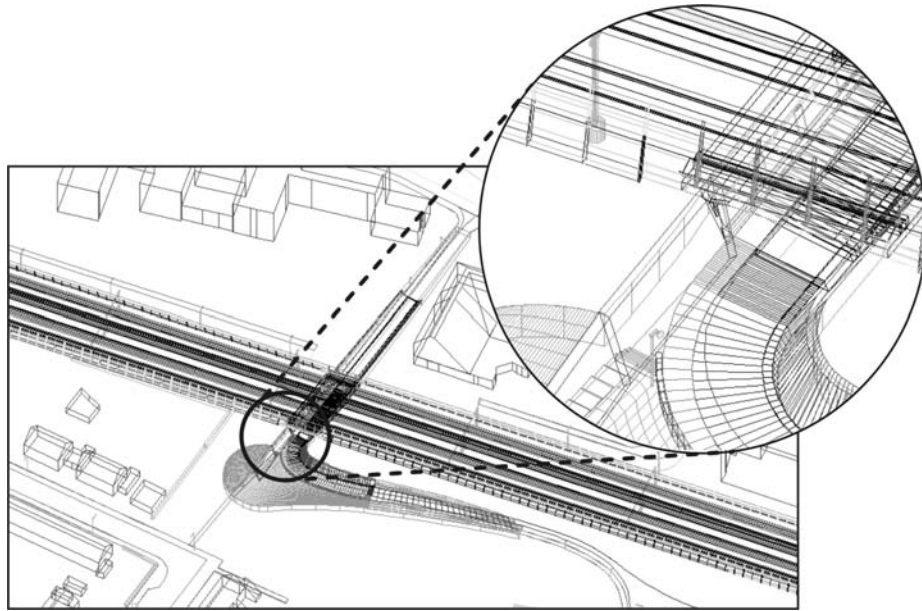

Figure 11.2: *The CAD model designed for a cycle tunnel in Houten, the Netherlands (by courtesy of Holland Railconsult).*

A case study was carried out to see how 3D CAD models, mostly covering local environments, could be converted into a set of 3D geo-objects [76]. This study revealed



that CAD models, mainly designed for visualisation, are not (directly) suitable for 3D cadastre purposes due to several reasons. The files can get unworkable large since mostly they are not made for interactive purposes but for generating animations. Furthermore they contain too much detail, objects can hardly be recognised in the file-based models and at least not easily be selected, and finally 3D spatial data in CAD models are defined by complex geometries which are mostly parametrically described. At the moment these files cannot automatically be converted into a set of individual objects defined as (simple) geometrical primitives that are available in spatial DBMSs (point, lines, polygons, polyhedrons). Another problem is that CAD models are mostly defined in local coordinate systems while 3D geo-information that needs to be combined with 2D geo-information should be defined within a national coordinate systems.

Although the use of CAD models (2D and 3D) still seems to offer a lot of potentials for the 3D cadastre (information on the third dimension is available in those models), generating relevant information out of these models requires further study. Using CAD models to obtain spatial models for 3D physical objects touches the fundamental issue of bridging the gap between GIS and CAD. This requires a further study on the fundamentals of GIS and CAD (see next subsection).

#### 11.2.4 Fundamental issues when linking GIS and CAD

CAD systems were originally developed to create (design) large-scale models (usually of relatively small size), without maintenance of attributes and not related to geographic coordinate systems. In contrast, GIS was able to manage geo-information obtained from some kind of measurement technique resulting in very large data sets, including attributes and supporting a variety of different geographic coordinate systems. Nowadays large-scale geo-information is a topic of interest for both CAD and GIS users, although CAD and GIS are still two different worlds. For example in ISO two different committees are responsible for standardisation in GIS (TC 211 Geographic information/Geomatics geo-information) and in CAD (TC 184 Industrial automation systems and integration).

CAD designers are increasingly confronted with the request to provide (and design) geo-information, i.e. the geometry of identifiable objects, with fixed location with respect to the earth, to which information can be linked. These data may serve a variety of purposes, e.g. spatial analyses, spatial planning, decision support, updating existing geographical data sets with planned (designed) objects etc.

The process of linking GIS and CAD raises some fundamental issues. The aim of CAD engineers is no longer producing a geometric and visual representation of a local environment. These local environments are now part of the complete world, by which real coordinates are needed. Since the same information is reused and updated, a system is needed to maintain the integrity and consistency of the spatial, spatial-temporal and thematic data which used to be core business of GIS. These trends require a tighter connection between GIS and CAD to be able to harmonise the geometrical primitives common in CAD software with the geometrical primitives and topological structure as defined by the GIS community, e.g. as defined by OpenGIS.

In 2D a lot of progress has been observed in linking GIS and CAD during the last years, e.g. cadastral parcels can be designed in CAD systems (with some kind of geographic extension) and can be maintained in a DBMS. These are indications that the border between GIS and CAD is fading at least from the user's perspective. In 3D, CAD and GIS integration is even more challenging. CAD software provides all kind of primitives to create a geometrical model (and their visual attributes) close to reality, however these primitives are not supported in the GIS world.

As was seen in section 8.1 CAD software and not GIS software contains a set of tools to design, edit and update large-scale 3D geo-data. Therefore a closer connection between GIS and CAD may be very beneficial for 3D GIS developments [143]. Questions that need attention in this process are how to use CAD primitives (e.g. parametric primitives) in an OpenGIS compliant environment (with possible extensions) and how can OpenGIS primitives be extended to use CAD functionalities (textures, shading etc.) to represent a model close to reality?

### 11.2.5 Querying

In the case the description of 3D physical objects is available in the cadastral database, the queries that are supported are:

- Is the owner of the parcel the same as the holder of the 3D physical object?
- Is this construction located above or below the surface?
- Which other 3D physical objects are located on top or below a certain 3D physical object?
- Which surface parcels intersect with a (projection of a) 3D physical, or vice versa: which 3D physical object intersects with a certain parcel?
- What rights are established on surface parcels intersecting with a 3D physical object? Which subjects (legal persons) hold these rights?
- What is the overlap-area between a 3D physical object and a 2D parcel?
- What is the volume of a 3D physical object (may be relevant for tax purposes)?
- What is the area of the footprint of a 3D object?

When physical objects are maintained in the cadastral DBMS these queries are possible. Once one has detected which parcels intersect with a 3D physical object, the juridical relationships between parcels and the 3D physical object can be obtained by administrative queries on the tables that contain the juridical relationships between parcels, rights/restrictions and subjects (persons).

## 11.3 Volume parcels in the DBMS

This section describes the issues of translating the selected conceptual model of a full 3D cadastre (containing infinite parcel columns and volume parcels) into a logical model concerning the following fundamentals: spatial data model (section 11.3.1), administrative data model (section 11.3.2) and how to populate the spatial data model (section 11.3.3). Section 11.3.4 describes the queries that are possible if a full 3D cadastre is implemented.

### 11.3.1 Spatial data model

The selected alternative of the full 3D cadastre maintains infinite and remainder parcel columns, volume parcels, restriction areas and restriction volumes. The volume parcels are related to an amount of space that is bounded. In the database, the volume parcels are modelled in 3D, whereas the infinite and remainder parcels are defined by parcel boundaries described in 2D and by parcel surfaces in 2.5D. The 3D description of these infinite and remainder parcels will not be visualised or constructed in the cadastral registration itself, but can be conceptualised by the user by subtracting the intersecting volume parcels from the infinite parcel column. If the parcel column does not intersect with a volume parcel, the ownership to the surface parcel is defined as described in the Civil Code (including space above and below the surface and reaches as high and as low the user has interest, see section 2.3.1).

#### Geometry

The volume parcels can be defined in a geometrical model in the same way as the 3D right-volumes: using the three data types that were tested and evaluated in chapter 7:

- define a 3D right-volume as a set of polygons defined in 3D (see section 7.1.2);
- define a 3D right-volume as one multipolygon defined in 3D (see section 7.1.2);
- using the user-defined 3D geometrical primitive (section 7.4).

The geometry of volume properties that are rather simple (defined with flat faces) can be modelled with these simple 3D primitives (using absolute z-values). However complex volume properties need to be modelled using more complex primitives. In the prototype the internal topological structure of volume parcels is maintained whereupon a geometrical realisation can be obtained. After the volume properties are described using the self-implemented 3D geometrical primitive they can be validated and queried in 3D. The geometry of infinite and remainder parcels are defined by parcel boundaries on the surface (based on the 2D topological structure), while the 2.5D surfaces of parcels are maintained in a TIN structure, preferably in an integrated view of parcel boundaries and point heights.

#### Topology

The infinite and remainder parcel columns, together with the volume parcels form a full partition of space. In the proposed implementation, the full partition of space is not implemented as such, because the infinite and remainder parcels are not modelled with volumetric representations. However, in densely built-up areas a full 3D partition of space could be considered. A 2D (or preferably 2.5D) topological structure is maintained for the parcels that are defined by surface boundaries. To assure the full 3D topological model, the following constraints need to be implemented:

- volume parcels should not intersect (touch is allowed);
- volume parcels should not cross surface parcels which are not subdivided into the third dimension, i.e. parcels on which no volume parcels have been established (this constraint should be used when volume parcels are inserted in the cadastral data base).

In the prototype the 3D characteristics of volume parcels are inserted in the topological structure using the Simplified Spatial Model (SSM) (section 7.2.4).

### 11.3.2 Administrative data model

In 3D property situations, only one case can be distinguished (instead of four as in both hybrid alternatives). The person who uses space above or below a surface belonging to another person is entitled with an ownership right to the volume parcel. In those cases the parcel or parcel(s) (implying the infinite parcel column) is (are) subdivided. When a person uses space above or below a surface from another person without establishing a volume parcel, the legal status of the situation is not established and cannot be registered in the cadastral registration.

#### Attributes

The principle of the full 3D cadastre is that the cadastral geographical data set (parcel columns and volume parcels) consists of a full partition of space. Every surface parcel or volume parcel is related to an amount of space. The attributes that are stored with these volume parcels do not differ much from those in the 2D case (except the attribute ‘area’ is replaced by ‘volume’).

#### Relationships

It is no longer necessary to project a 3D property situation on the surface, since it is possible to establish volume parcels that have no relationship with surface parcels. Only when the volume parcel is created (and subtracted from the infinite parcel column) the owner of the surface parcel should agree with the subdivision. The deed establishing the volume parcel needs only in this case to mention the surface parcel. The boundaries of the volume parcel are defined in a 3D survey plan. This procedure is quite similar to the horizontal subdivision of parcels in which a 2D survey plan is required. In the future the volume parcel can be sold, without relating it to the underlying surface parcel (with the exception that rights on the surface parcel might be necessary to assure the use of the volume parcel, e.g. when the surface parcel is needed to access the 3D property). Future transfer of a surface parcel that intersects with a volume parcel will only transfer the remainder of the parcel that is left after subtraction of the intersecting volume parcel. In contrast to the 3D right-volumes, a subdivision of a surface parcel has no consequences for the volume parcels intersecting with the concerning parcel. Since this situation is reflected in the (3D) cadastral geographical data set, querying the 3D cadastral geographical data set will make the property situation clear to the parties involved, e.g. the transfer will not mean transferring an infinite parcel column. The legal status of the situation can be obtained by tracing the ownership back in history, as is current practice in case of apartment rights: one deed is necessary to establish the apartment units (*splitsingsakte*). After this transaction the apartment unit exists as a separate unit in the (administrative part of the) land registration. However, apartment units always keep a legal relationship with the other apartment units in an apartment complex in contrast to volume parcels, which are totally independent of other property units.

### 11.3.3 Data collection

Every volume parcel should be established by means of a 3D survey plan (as in the case of volumetric parcels in Queensland, Australia, see section 4.6). Note that surveying in 3D might be difficult where the volume parcel does not relate to a built

construction and also when the geometry of a volume parcel is complex. The 3D survey plan should define how the volume parcel is bounded by defining all the corner coordinates with x, y, and z-coordinates in the National Height Datum. The insertion of volume properties in the cadastral database makes it possible to check the volume property (is the property closed, are all faces planar) and to check the constraints to assure the topological partition of space (the volume property should not intersect another volume property; the volume property should not intersect a parcel on which no volume properties have been established). After these checks the geometry of the volume property can be inserted into the cadastral geographical data set.

A procedure should be developed and defined to convert the 3D survey into an internal topological structure and into geometrical primitives in the database. If this procedure is clear, the process from surveying to insertion in the cadastral database can be streamlined. In the prototype the whole process from 3D survey plan to geometrical and topological representations in the cadastral database has been implemented.

### 11.3.4 Querying

The queries that are supported by the full 3D cadastre are:

- Is this volume parcel valid (closed, planar faces)?
- Are these volume parcels overlapping? (This query can be used in constraints.)
- Is this volume parcel intersecting a parcel that is defined by an infinite parcel column (can be used in constraints)?
- To what space is this person entitled?
- Does this parcel refer to an infinite or a remainder parcel?
- What are the 3D neighbours of this parcel or volume parcel?
- Show the cadastral map in 3D.

## 11.4 Maintaining history in the 3D cadastre

When the registration of 3D physical objects, 3D right-volumes or 3D volume parcel becomes practise, updates will occur by which version managing is necessary, which is the 4D aspect of data modelling. The current cadastral DBMS maintains history as described in [136] in a self-implemented extension since history is not supported by mainstream DBMSs. History is currently maintained at record level (only for the spatial part of the cadastral database). For every object (parcel and boundary) a start-time and an end-time are stored. When an object is created the current time is set as start-time in the new record and a time in the faraway future is set as end-time. This is necessary to be able to reconstruct the correct situation at any given point in history, e.g. give me the cadastral map of October 10th, 1988. The unique identifier for objects (key) is the pair (object-id, start-time). Only when a new object is created or an old-object is drastically changed (e.g. subdivided) a new object-id will be used. For simple updates a creation of a new object version (with same object-id) is the way to capture full history.

This structure assures topologically consistent data. For topological references, only the object-id is used to refer to another object. In the situation that a referred object is updated and keeps its object-id, the reference does not change. This avoids in a topologically structured data set, the propagation of changes for many objects when only one object is changed as all objects are somehow connected to each other. In case the object-id of a referred object is changed (becomes a different object), the referring object has also to be updated.

#### **11.4.1 History for 3D right-volumes**

History for 3D right-volumes can be maintained in a similar way if we assume that the 3D internal topological structure is the basic structure that is maintained. When the face is the lowest dimensional topological object, history can be maintained on faces similar to parcel boundaries. When a face is moved, the face is updated. If this is not seen as a major adjustment, no new object-id will be created for the face. The 3D geometrical description of 3D right-volumes will change because the object consists of references to the faces which are updated. When nodes are the lowest dimensional objects, the same apply for nodes (nodes are updated and the geometrical description of faces and 3D right-volumes change through their references). When a new object-id is created for lower-dimensional objects, the change of such an object will propagate changes in the higher-dimensional objects that refer to these objects. Topological consistency of different time stamps should therefore always be checked while updating.

#### **11.4.2 History for 3D physical objects**

History on the geometry of 3D physical objects can be maintained on the whole object. A start-time and an end-time are maintained as attributes for 3D physical objects. Updates work in the same way as updates of parcel boundaries. A new object version will be created and the old one will be ended when an update occurs. Since no topology is maintained between 3D physical objects, updates of 3D physical objects do not affect other 3D physical objects. However, consistency checks should assure that 3D physical objects, also in the new situation, do not overlap. In addition, changes will affect other objects that contain references to the physical objects (e.g. where the holder of a physical object refers explicitly to the physical object or where the relationship between parcels and physical objects is maintained explicitly).

#### **11.4.3 History in a full 3D cadastre**

In case of a full 3D cadastre, the history can be maintained in the same way as in current registration if we assume that both the 2.5D topological structure is maintained (for infinite and remainder parcels) as well as the internal 3D topological structure and a full partition of space in densely built-up areas. If the lower dimensional objects are updated and no new object-ids are created, the geometrical description of the higher dimensional objects will change through the defined references. However,

in the new situation consistency checks should assure that 3D right-volumes do not overlap in 3D. Updates of an object (surface parcel or volume parcel) should result in a new object-id if the updates are major changes (e.g. in case of a subdivision) to avoid losing some of the history. In this process topological consistency of different time stamps needs special attention.

## 11.5 Conclusions

This chapter described the issues that need to be considered when translating the conceptual models of 3D right-volumes, 3D physical objects and the full 3D cadastre into logical models for the selected object relational database structure.

Concerning spatial models, current techniques are appropriate for modelling (the simple) geometry of 3D right-volumes and for modelling simple volume parcels, although the 3D topology structure needs more research (e.g. implementing consistency checks as part of the DBMS).

Geometry of both 3D physical objects and complex volume parcels is harder to model within current techniques. In order to precisely define the geometry of 3D physical objects and complex volume parcels in the DBMS, research is needed on storing complex 3D geometries (more complex than a polyhedron) in a DBMS. Topology between objects in the proposed solutions for a 3D cadastre (3D right-volumes, 3D physical objects and volume parcels) is not needed, only in the case of volume parcels in densely built-up areas. Spatial relationships between two 3D geo-objects can be obtained by spatial functions. Topology forms therefore no bottleneck for implementing the logical models of these objects, except in the case a full 3D partition is needed.

Populating the spatial data models with data was another issue that was considered in this chapter. The data collection in case of 3D right-volumes and volume parcels requires 3D surveys instead of 2D surveys. Procedures should be set up that regulates the content of 3D survey plans (what data should be incorporated and how?). In case of 3D physical objects one could think of using the CAD designs of the physical objects. However, as was described in this chapter, it is not straightforward to convert a CAD design to a GIS model (i.e. a collection of objects geometrically defined in real-world coordinates, with both spatial and non-spatial attributes).

Apart from spatial and administrative modelling, 4D requirements for the logical models were also considered in this chapter: how to maintain history. History is not supported in current DBMSs. However history in the three logical models for the 3D cadastre could basically follow the same approach as history is currently implemented in the cadastral DBMS, where spatial objects have two additional attributes (tmin and tmax) to implement history.

Based on the considerations for the logical models as described in this chapter, the prototypes were implemented. The prototypes contain the basic aspects of the three selected alternatives. In chapter 12 the prototypes will be evaluated as well as the conceptual and logical models of the different alternatives, by applying the prototypes to the case studies introduced earlier in this research.





## Part IV

# Realisation of a 3D cadastre



## Chapter 12

# Prototypes applied to case studies

Three conceptual models of a 3D cadastre (the registration of 3D right-volumes, 3D physical objects and the registration of volume parcels) were completed in chapter 10. The considerations for translating these conceptual models into logical models for an object relational database structure were described in chapter 11. To evaluate the conceptual models, the two logical models of the hybrid cadastre (the registration of 3D right-volumes and the registration of 3D physical objects) were populated with data concerning the Dutch 3D property situations introduced in chapter 3. The logical model for the combined 2D/3D alternative of the full 3D cadastre (volume parcels and infinite parcel columns) was populated with data concerning the case study from Queensland, Australia introduced in chapter 4. The reason for this was that the juridical doctrine in Queensland provides already the possibility of establishing multilevel ownership, while in the Netherlands the property to real estate is still land (surface) oriented (as in the hybrid case). The prototype implementations applied to the case studies resulted in an evaluation of possibilities and constraints of the proposed conceptual models.

Section 12.1 describes the prototypes of the hybrid cadastre applied to the Dutch 3D property situations. Section 12.2 describes the full 3D cadastre prototype applied to the case study in Queensland, Australia.

The chapter ends with conclusions.

For the prototype implementations the technical framework that was explored in part II of this thesis was used. The 3D data are maintained in Oracle Spatial 9i. The data are accessed with both MicroStation GeoGraphics and Web based techniques (ArcGIS has not been used for accessing the data, since ArcGIS is not yet able to visualise vertical polygons via ArcSDE from an Oracle Spatial database). Since no height data was available for the Dutch case studies, height information on parcels was not used in the Dutch case studies. For the case study in Queensland ArcView (ArcGIS) was used to generate an appropriate TIN structure containing a 2.5D representation of the cadastral base map.

## 12.1 Prototypes of the hybrid cadastre

This section describes the concepts of the two alternatives of the hybrid cadastre (3D right-volumes and a 3D physical object registration) applied to the Dutch case studies that were introduced in chapter 3. The prototype implementations have not been applied to the case of utility pipelines (case study 6 in chapter 3), since 3D cadastral registration of the pipelines is similar to the registration of the drilled tunnel in rural area (case study 5 in chapter 3) and it would yield the same results. The case study of The Hague Central Station (section 12.1.2) will be used to show the process of creating 3D representations of 3D right-volumes and their data structure in detail. In section 12.1.6 both alternatives of the hybrid cadastre will be evaluated.

### 12.1.1 Case study 1: Building complex in The Hague

#### 3D right-volumes

Figure 12.1 shows the implementation of the registration of 3D right-volumes applied to the building complex in The Hague. It is not the building itself which is registered, but the 3D right-volumes established for the building, together with their 3D representation. These 3D right-volumes are the 3D description of the space to which the building owner is entitled with the following limited rights: right of superficies on parcel 1719 (parcel in the middle) and right of long lease on parcel 1720 (parcel on the right) (the cadastral map of the building containing the parcel numbers was shown in figure 3.2). No 3D right-volume is maintained on parcel 1718 (parcel on the left) because no limited real right has been established on this parcel (the parcel owner is the same as the building owner), which indicates that the ownership right on this parcel applies to the whole parcel column.

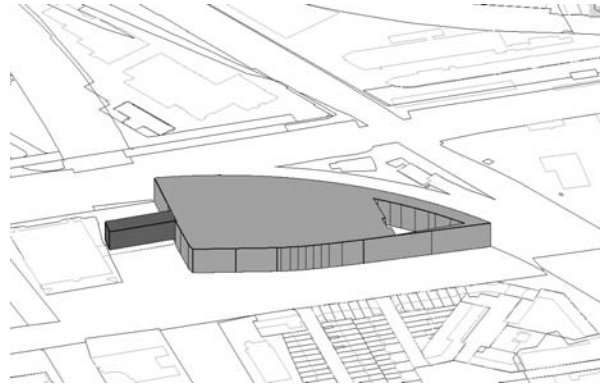

Figure 12.1: *Registration of 3D right-volumes: right of ownership on the left parcel, right of superficies on the middle parcel and right of long lease on the right parcel.*

Note that the 2D extent of the 3D representations (footprint) is the same as the parcel boundaries. The 3D descriptions give an indication of the space to which the owner of the building is entitled.

The 3D right-volumes refer to non-spatial information such as the person who is entitled to the 3D right-volume and the type of right. The legal status of the building can be obtained by querying the 3D right-volumes via the right association (what is the right associated with the 3D right-volume, who is the subject of the right). The relationship between 3D right-volumes and the whole real estate object (whole building in this case) may also be maintained (is not maintained in this case).

The legal status of the space above and below the building complex is not explicitly registered. It is disputable who owns the space above the construction that is registered with a right of superficies, unless this is explicitly stated in the deed. However, in current deeds the exact location of the right of superficies is often not clearly described. In the case of long lease, the long leaseholder has the right to use the whole parcel column within the conditions stated in the deed. The condition can restrict the long leaseholder in using the whole parcel column. In this specific case the deed did not contain conditions with respect to the spatial extent of the right established on parcel 1720.

In this case study the heights of the 3D right-volumes (relative heights with respect to surface parcel) are related to the construction as built (and horizontal planes are used to define the 3D right-volumes as the definition of 3D right-volumes prescribes). If the space to which the rights apply is precisely defined in 3D in deeds and in 3D survey documents, this information can be used to construct the 3D right-volumes. In that case it can happen that the visualisation of the 3D right-volumes differs from the actual built construction (e.g. when a right of superficies exceeds the actual construction in view of future plans).

### 3D physical objects

Figure 12.2 shows the implementation of the registration of 3D physical objects applied to the building complex in The Hague. The physical object in this figure represents the factual building. Also in this case, the z-values used to define the physical object are defined relative to the surface.

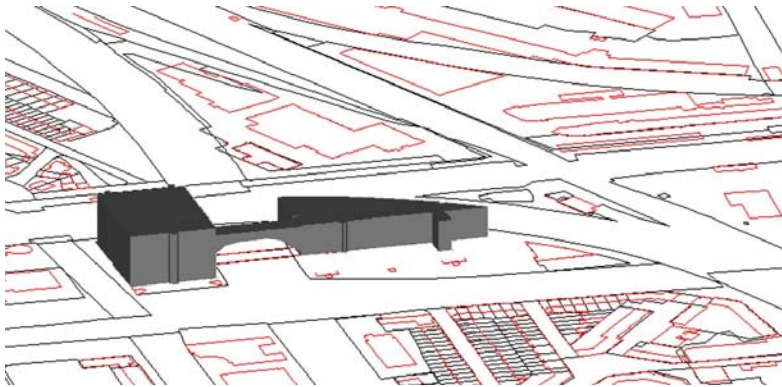

Figure 12.2: *Registration of a 3D physical object.*

Although the building crosses parcel boundaries, the whole building is registered as one object in the cadastral database. Separated from the parcels and outlines of

buildings, the 3D physical object is maintained in a table containing the id of the object and the 3D geometry of the object (in this case defined as one multipolygon defined in 3D). The 3D object can be visualised and queried with a front-end in combination with 2D (preferably 2.5D) cadastral data. The legal status of the building is still registered by establishing rights on surface parcels. Consequently, the legal status of the building can only be obtained by examining the surface parcels. Since the 3D location of the building is integrated with the cadastral geographical data set, this information can be used in the querying process.

## 12.1.2 Case study 2: The Hague Central Station

### Generating 3D right-volumes

The process of automatically generating 3D right-volumes is described in this section using the case of The Hague Central Station.

For every parcel on which limited real rights or apartment rights are registered, a z-list is generated, that defines the upper and lower limits of (limited) rights (and apartment rights) established on the specific parcel. For example, in the case of The Hague Central Station, the vertical extents of the rights on the parcel that contains the tram and bus station and the railway platform are as follows (parcel 13295; see figure 12.3 (b)):

- railway platform (owned by NS Vastgoed): 0 to 6 m
- tram/bus station (right of superficies, holder municipality of The Hague): 6 m to 12 m.

Since the notarial deed gives no information about the boundaries of the established right of superficies for the bus/tram station in the third dimension, the levels were obtained by measuring the building (construction).

The z-list is inserted in the 3D right-volume table, as described in section 11.1.2. For The Hague Central Station the 3D right-volume table is as follows (implying fifteen 3D right-objects):

PARCEL	Z_LIST
12131	Z_ARRAY(0, 12, 40)
13290	Z_ARRAY(0, 12)
13288	Z_ARRAY(0, 12)
13289	Z_ARRAY(0, 12)
13294	Z_ARRAY(0, 3, 12)
13291	Z_ARRAY(0, 3, 12)
13293	Z_ARRAY(0, 3, 12)
13292	Z_ARRAY(0, 3, 12)
13295	Z_ARRAY(0, 6, 12)

Non-spatial information on the 3D right-volumes (person who is entitled to the space; what right is established to entitle the person to the space) can also be obtained. In these first implementations the type of right and the person entitled to a 3D right-volume (right-owner) are made available via views on the AKR base tables ('right' and 'subject'). The list of owners and the list of types of right for every level are presented as arrays (Abstract Data Types) in the following view:

```
SELECT parcel, o_list, r_list FROM dh_input_3d_view;
```

PARCEL	O_LIST	R_LIST
12131	O_ARRAY('NS VASTGOED', 'STICHTHAGE')	R_ARRAY('App', 'App')
13290	O_ARRAY('NS VASTGOED')	R_ARRAY('VE')
13288	O_ARRAY('NS VASTGOED')	R_ARRAY('VE')
13289	O_ARRAY('NS VASTGOED')	R_ARRAY('VE')
13294	O_ARRAY('NS VASTGOED', 'GEMEENTE DEN HAAG')	R_ARRAY('EVOS', 'OS')
13291	O_ARRAY('NS VASTGOED', 'GEMEENTE DEN HAAG')	R_ARRAY('EVOS', 'OS')
13293	O_ARRAY('NS VASTGOED', 'GEMEENTE DEN HAAG')	R_ARRAY('EVOS', 'OS')
13292	O_ARRAY('NS VASTGOED', 'GEMEENTE DEN HAAG')	R_ARRAY('EVOS', 'OS')
13295	O_ARRAY('NS RAILINFTRUST BV', 'GEMEENTE DEN HAAG')	R_ARRAY('EVOS', 'OS')

9 rows selected.

A PL/SQL script has been written to generate the spatial description (topology and geometry) of the 3D right-volumes which is linked to the non-spatial information.

**Topological structure** DBMSs do not (yet) support topology structure management (2D nor 3D). Therefore, the topological structure has to be defined in a DBMS by means of user-defined references. For the prototypes we use the Simplified Spatial Model of [240]. A 3D geometry object is therein defined as a polyhedron consisting of nodes and faces (see section 7.2.4). A PL/SQL script was written to generate the BODY, FACE and NODE table based on the z-list containing height values of properties on one parcel and the geometry of the parcel. In this model the faces within one parcel are shared between bodies as it should be in a full topological model and nodes are shared between faces.

**From topology to geometry** To realise the geometry of the 3D right-volumes, based on the topological tables, a function has been written. In this function the nodes of one 3D right-volumes are retrieved by the following query (see section 7.2.4) whereupon the 3D geometry is reconstructed:

```
/* for the body bid=1*/
SELECT body.bid,face.fid, face.seqn, node.nid, node.x, node.y, node.z
FROM body, face, node WHERE body.bid=1;
```

Having the geometry it is possible to visualise, query and edit the data in GIS and CAD software and to perform spatial queries in the DBMS.

**Geometrical primitives** The geometry of 3D right-volumes is generated by means of the implemented realisation function and be made available in a view. The realised geometry of 3D right-volumes can be defined as a polyhedron data type as it is possible within current techniques: either as a set of polygons in 3D or as a multipolygon defined in 3D. For the prototypes we used the multipolygon representation since this representation is recognised as one object by front-ends. As part of the implementation of the 3D primitive in the DBMS (section 7.4), a conversion tool has been written to convert 3D objects stored as multipolygons into the 3D polyhedron primitive. For the 3D right volume with bid=3 (which is the 3D right-volume on parcel 13290), this looks as:

```

SELECT return_polyhedron(shape) FROM dh_multipol WHERE bid=3;

RETURN_POLYHEDRON(SHAPE)
-----
(SDO_GTYPE, SDO_SRID, SDO_POINT(X, Y, Z), SDO_ELEM_INFO,
SDO_GEOMETRY(3002, NULL, NULL,
-- 3002 refers to geometrytype: (fictive) 3D polyline
-- in sdo_elem_info_array the elements are listed, first triplet is a line,
-- followed by the (outer) faces (starting offset, e_type, interpretation code)
SDO_ELEM_INFO_ARRAY(1, 2, 1, 67, 0, 1006, 78, 0, 1006, 82, 0, 1006, 86, 0,
1006, 90, 0, 1006, 94, 0, 1006, 98, 0, 1006, 102, 0, 1006, 106, 0,
1006, 110, 0, 1006, 114, 0, 1006, 118, 0, 1006, 122, 0, 1006),
-- in the ordinate array, first the vertices are listed
SDO_ORDINATE_ARRAY(82140054, 455389862, 0, 82124400, 455378306, 0,
82103103, 455361960, 0, 82036913, 455311156, 0, 82054915, 455287619, 0,
82063070, 455293838, 0, 82107247, 455327528, 0, 82151729, 455361401, 0,
82161846, 455369105, 0, 82159770, 455371792, 0, 82143723, 455392571, 0,
82140054, 455389862, 12000, 82124400, 455378306, 12000,
82103103, 455361960, 12000, 82036913, 455311156, 12000,
82054915, 455287619, 12000, 82063070, 455293838, 12000,
82107247, 455327528, 12000, 82151729, 455361401, 12000,
82161846, 455369105, 12000, 82159770, 455371792, 12000,
82143723, 455392571, 12000,
-- then the faces, defined by references to the nodes
1, 2, 3, 4, 5, 6, 7, 8, 9, 10, 11, 1, 12, 13, 2, 2, 13, 14, 3,
3, 14, 15, 4, 4, 15, 16, 5, 5, 16, 17, 6, 6, 17, 18, 7,
7, 18, 19, 8, 8, 19, 20, 9, 9, 20, 21, 10, 10, 21, 22, 11,
11, 22, 12, 1, 12, 13, 14, 15, 16, 17, 18, 19, 20, 21, 22))

```

Once a 3D right-volume is defined with the 3D polyhedron primitive, the implemented 3D functions can be performed on it, such as a validation, 3D area or 3D volume calculation (in this case in  $mm^3$ ):

```

SQL> SELECT bid, volume(return_polyhedron(shape)) FROM dh_multipol;

BID          VOLUME(RETURN_POLYHEDRON(SHAPE))
-----
1            1.6024E+13
2            5.3413E+12
3            1.1888E+13
4            4.6118E+11
5            5.7372E+11
6            6.6815E+11
7            6.6815E+11
8            2.6769E+11
9            2.6769E+11
10           6.8230E+11
11           6.8230E+11
12           1.0486E+12
13           1.0486E+12
14           4.6100E+13
15           4.6100E+13
15 rows selected.

```

**Topological model compared to geometrical primitives** Disadvantages of using a topological model are:



- The data model needs three tables instead of just one (as in the multipolygon or polyhedron case).
- Since the DBMS does not recognise topology, inserting the data is one thing, but updates require a lot of effort and experience or other software. Also the consistency of the data has to be checked by other software (until DBMSs offer topology structure management in 3D).
- Querying can be difficult at SQL level (topology is not recognised by DBMSs), for geometrical queries it is always necessary to generate a realisation of the object, instead of being able to use the spatial queries available in the DBMS directly.

Another problem that was mentioned in chapter 7 is the required storage capacity of the topological structure compared with the storage capacity needed for the geometrical primitives. Every row in the tables defining the topological structure has its overhead, also the references require a lot of storage capacity. To illustrate this we queried the storage capacity needed for the tables of the topological structure in the case of The Hague Central Station, which is twice the storage capacity needed for the polyhedron representation.

Advantage of the topological structure is that topology structure management can be used in the storage and the retrieval of data. For example, by means of the shared (horizontal) faces one can easily find the upper and lower neighbours of a 3D right-volume.

#### **Evaluating 3D right-volumes for The Hague Central Station**

The visualisation of the 3D right-volumes for The Hague Central Station (figure 12.3 (a)) gives a clear insight of the various rights in the building complex. It not only gives an indication of the spatial extent of the property rights on each of the parcels concerned, it also shows the relation between the rights established on adjacent parcels. The 3D map of The Hague Central Station (classified on subject) clearly shows that the municipality of The Hague is not only holding the right of superficies on parcel 13295 (the big parcel in the centre, with the railway platforms on ground level), but also on parcels 13291, 13292, 13293 and 13294 (see the cadastral map in figure 12.3 (b)). At one glance one can see that the municipality is owner of the bus/tram station on the second floor, with the adjacent entrances at left and right hand side of the railway station. This is an advantage compared to the traditional 2D cadastral map. More advanced visualisation techniques may be needed in complex clusters of 3D right-volumes (e.g. make certain 3D right-volumes semi-transparent).

In this case the space of the railway platforms on parcel 13295 is visualised, however in the strict definition of 3D right-volumes (right-volumes only relate to positive rights) this is not correct. The space occupied by the railway platform belongs to the space that is left for NS Railinfratrust BV after the space related to the right of superficies has been subtracted from the infinite parcel column. The 3D right-volumes on parcel 13288, 13289 and 13290, which also have been related to the construction as built, are also visualised. This is also not correct according to the definition of 3D right-volumes since these parcels are hold in full ownership.

Again the limits of the 3D right-volumes are related to the construction as built. However it would be better to define the limitations in the deed based on 3D survey plans.

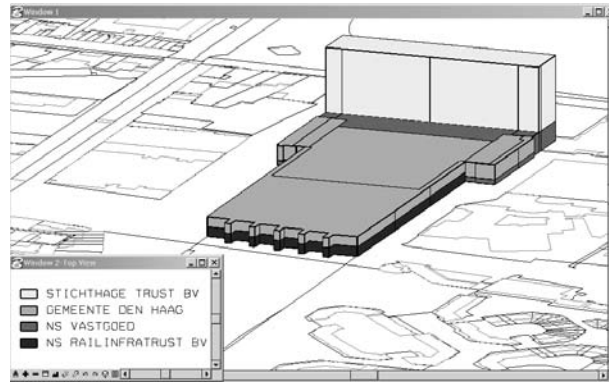

(a) 3D representations of right-volumes.

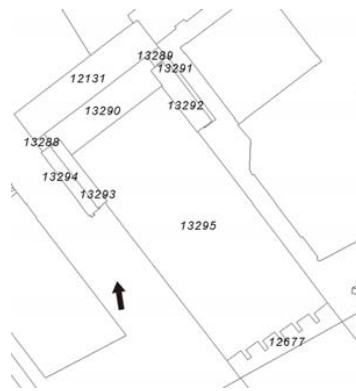

(b) 2D cadastral map

Figure 12.3: *Cadastral representation (2D and 3D) for The Hague Central Station.*

For example who owns the space above the bus/tram station and the space below the railway platform? At the moment this seems not a relevant question. However if a business company wants to build a business centre on top of the bus/tram station, the ownership of the space above the tram/bus station will become an important issue.

### 3D physical objects

The 3D map in figure 12.3 only shows the 3D right-volumes and not the physical objects (although in this case the 3D right-volumes are related to the physical objects). The physical objects in the case of a physical object registration are maintained to visualise constructions, not subdivided by parcels that are crossed. In some cases the physical object coincides with a (conglomerate of) 3D right-volume(s). This is also the case for the The Hague Central Station where 3D right-volumes are related to the construction as built due to lack of other information. For example the physical

object for the bus/tram station is a combination of the 3D right-volumes established for the bus/tram station including the entrances on parcels 13291, 13292, 13293, 13294, 13295. In case of the railway platform, the whole platform (or railway) would be registered as one 3D physical object also on parcels that are in full ownership of NS Railinfratrust BV. Normally, the collection of 3D right-volumes that refers to a whole real estate object embraces the space occupied by a 3D physical object. Except on parcels for which no cadastral recording of the 3D situation has taken place since on those parcels no 3D right-volumes are established.

### 12.1.3 Case study 3: Apartment complex

#### 3D right-volumes

The case of the apartment building is more complex, since on the ground floor there are three apartment units and on the first and second floor two units, all established on one parcel. Furthermore the building covers not the whole parcel. This is quite common for apartment complexes. Consequently the footprints of the apartment units on every floor do not coincide with the parcel boundary.

To be able to apply the z-list with upper and lower limits of rights established on one parcel, the 2D boundaries of the individual apartment units are generated, which resulted in the 2D objects as shown in figure 12.4, with object 'a' (whole building minus 'b' and 'c'), objects 'b' and 'c' defined for the ground floor and object 'd' and 'e' (both half of the building) defined for the first and second floor. The garden-area (which belongs to the apartment unit on the ground floor) and the space above this area are not included in the 3D right-volumes, although this could have been done.

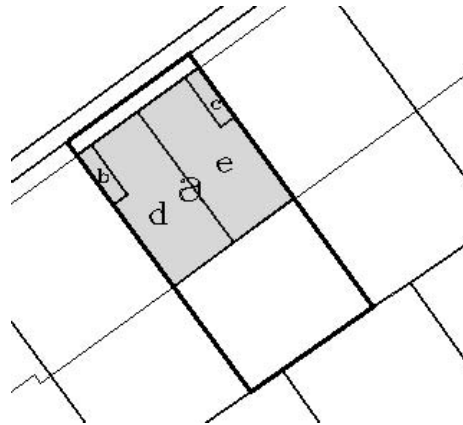
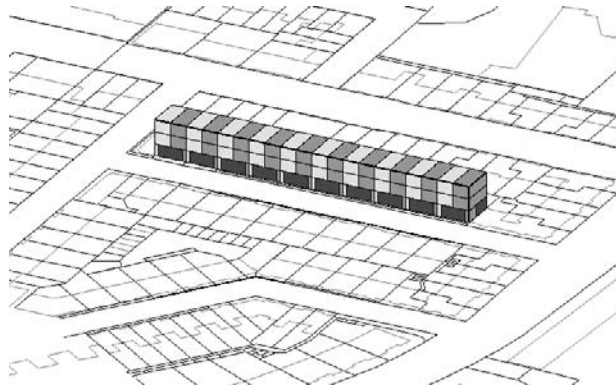

Figure 12.4: *The generated 2D objects: footprints of individual apartment units on every floor. The grey part is the extent of the building.*

The 3D right-volume table for the whole apartment complex is as follows:

PARCEL	Z_LIST
6408_a	Z_ARRAY(0,3)
6408_b	Z_ARRAY(0,3)
6408_c	Z_ARRAY(0,3)
6408_d	Z_ARRAY(3, 10)
6408_e	Z_ARRAY(3, 10)

'Parcel' does in this case not refer to parcel numbers but to the 2D polygons of apartment units generated to define inner boundaries of the apartment units in order to be able to extract them in 3D. The drawings added to deeds of subdivision could be used to construct the 2D footprints, that is to say when the spatial information on the drawings is defined in (or can be transferred into) world-coordinates and in vector-format. The visualisation of the generated 3D right-volumes is shown in figure 12.5.



(a) All apartments in the street

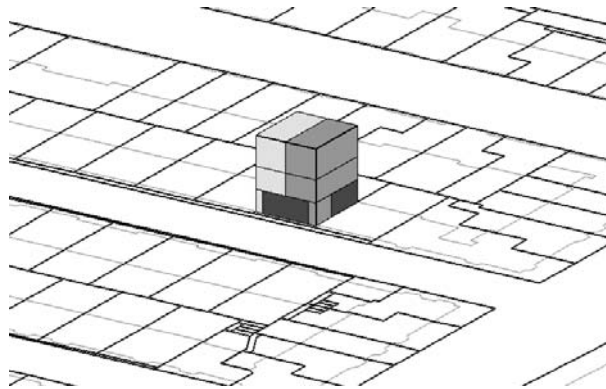

(b) The apartment complex of the case study which is the second complex from right

Figure 12.5: *Apartments as 3D right-volumes. The horizontal lines between the first and second floor are for visualisation purposes.*

This case shows some complications. Not only a horizontal division of the parcel column is needed to define the 3D right-volumes but also a vertical division of the parcel area (dividing the parcel into smaller parts). If only one 3D right-volume were to be established for the whole parcel area, it would not reflect the real situation and it would definitely not provide a clear picture of the situation (3D right-volumes would overlap) which is one of the main aims of 3D registration. However the generation of the smaller parts (footprints of apartment units) is a change in the concept of 3D right-volumes if they have the same legal status as ‘normal’ (traditional) parcels.

### 3D physical objects

The physical object registration would in this case be the same as the 3D right-volume registration in which the 3D right-volumes are related to the apartment units. The apartment units are the physical objects that would be identified as registering objects in the physical object registration. Although it can be disputed if a 3D physical object registration is appropriate for apartment units, since the main objective of a 3D physical object registration is to provide more insight into locations containing infrastructure objects (crossing parcel boundaries and mostly meant for public good) rather than to improve insight into private property situations.

## 12.1.4 Case study 4: Railway tunnel in urban area

### 3D right-volumes

The 3D right-volume table for the railway tunnel in Rijswijk is as follows (for the parcel numbers see figures 3.8 and 3.9):

```
7854: Z_ARRAY(-20, 0, 4) -tunnel with kiosk on top of it
7855: Z_ARRAY(-20, 0, 4) -tunnel with kiosk on top of it
7857: Z_ARRAY(-20, 0, 12) -tunnel with railway station on top of it
7944: Z_ARRAY(-20, 0, 12) -tunnel with public space on top of it
7949: Z_ARRAY(-20, 0, 12) -tunnel with public space on top of it
```

For parcel 7945 and parcel 7946 no 3D right-volumes are generated since NS Railinfratrust BV has a full ownership on these parcels.

The right of superficies established for the municipality to hold the public area at street level is in this case supposed to be bounded on a level of 12 meter above the surface level. This is not the real case.

In the deed, the space of the right of superficies is defined as ‘above the surface level’. How to visualise this? There are basically three solutions:

- make a 3D description of just the street level (figure 12.6 (a)); this representation could be confused with a 3D right-volume that is limited in height and is therefore not a good solution;
- make a very high (‘unlimited’) 3D right-volume (figure 12.6 (b)); this also does not reflect the real situation correctly, since it looks as a very high building has been built;
- use an “open” polyhedron, without a top (and the side faces visualised until a reasonable height related to the height of the physical object).

All these alternatives are vague indications that something is happening above the surface. The question is if these alternatives are correct and clear representations of the real situation.

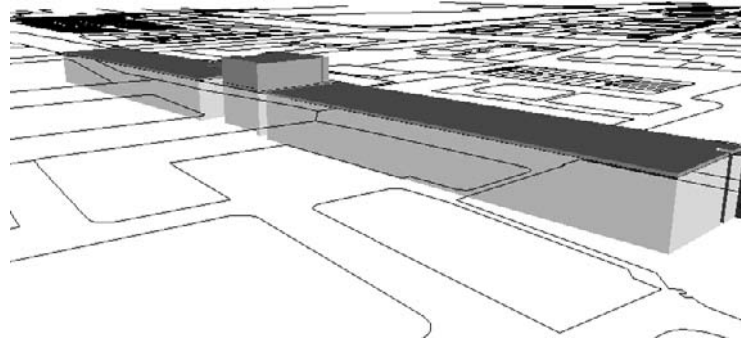

(a)

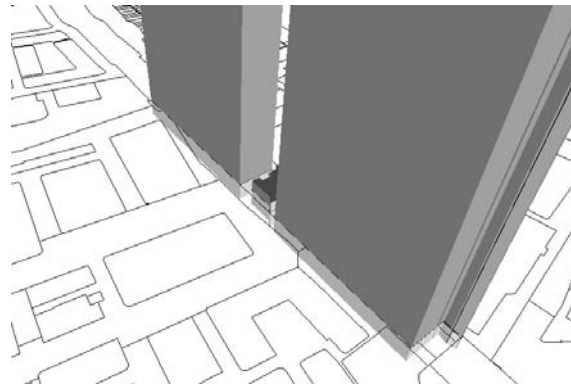

(b)

Figure 12.6: *The first two alternatives for unrestricted right of superficies (third option is not displayed). Note that the lowest 3D right-volumes (for the railway tunnel) are located below the surface (below the  $z=0$  plane).*

The 3D registration of this situation gives significantly more insight compared to the registration in the current cadastre. It is now possible to see not only which persons have a right on a parcel, but also where these rights are located in space. Although the gaps in the registration caused by the full ownership of NS Railinfratruster BV on some parcels as well as the undefined 3D right-volumes when 3D right-volumes are defined ‘above street level’ makes the situation unclear. The real situation might be better reflected when the tunnel itself is registered as 3D physical object.

### 3D physical objects

The registration of physical objects registers the tunnel as one whole object, together with the spatial extent of the tunnel and information on the tunnel. The station building could be registered as one physical object as well. The fragmented pattern of parcels could then be avoided. 3D information on the tunnel was not available for this research, but it would have been similar to the registration of the 3D physical object in the case of the railway tunnel in rural area as described in the next case. The 3D location of the tunnel helps to understand the real situation.

## 12.1.5 Case study 5: Railway tunnel in rural area

### 3D right-volumes

Also in the case of the HSL, the 3D right-volumes start with the surface parcel boundaries. In order to avoid the situation where part of parcels that do not cross the tunnel are encumbered with a right for the tunnel (according to Dutch legislation), the intersecting parcels need to be subdivided. As was seen in section 3.2.2 most intersecting parcels were already subdivided but have not been surveyed yet. Therefore we created (fictive) new parcel boundaries using the new parcel boundaries as shown in figure 5.2. These new parcel boundaries were created by a spatial overlay in the database. First the tunnel axis, stored as a line, was buffered with 15 meters, based on the diameter of the tunnel (15 meters) and a safety zone of 7.5 meters at each side ('shape' in this query is the geometry column of the table in which the tunnel is represented with the centreline):

```
CREATE table hslbuffer AS
SELECT sdo_geom.sdo_buffer(shape,15000,1) shape
FROM hsltunnel;
```

Then a spatial overlay was carried out between the layer containing the tunnel buffer and the (realised geometry of) parcels:

```
CREATE TABLE hsl_parcel_new AS
SELECT parcel, municip, osection,
sdo_geom.sdo_intersection(hb.shape,hp.return_polygon(object_id),10) shape
FROM hsl_parcel hp,hslbuffer hb;
```

The newly created parcels (as well as the remainder parcels) got a unique parcel number. These new parcels were used to create the 3D right-volumes. The spatial extent of the 3D right-volumes is the spatial extent of the spaces where the rights established for the tunnel apply to: in this case the same as the 3D spatial extent of the tunnel under the specific parcels extended with a safety zone of 7.5 meters (in all directions). The upper and lower limits of a 3D right-volume for a specific parcel were derived from two sources: (1) the 3D centreline of the tunnel that intersects with the specific parcel and (2) information on the extent of rights established for the tunnel (diameter of 15 meter plus safety zone of 7.5 meter).

The obtained upper and lower limits of the right-space per parcel were inserted in the 3D right-volume table and used for the generation of 3D right-volumes for the tunnel (the z-values are in mm and in NAP):

MUNICIP	SECTION	PARCEL	Z_LIST
HZWO	E	740	Z_ARRAY(-28809, -13598)
HZWO	E	2396	Z_ARRAY(-28384, -12055)
HZWO	E	2397	Z_ARRAY(-26826, -3426)
HZWO	F	57	Z_ARRAY(-37501, -21069)
HZWO	F	58	Z_ARRAY(-35970, -20869)
HZWO	F	59	Z_ARRAY(-40100, -23997)
HZWO	F	60	Z_ARRAY(-38960, -23368)
HZWO	H	14	Z_ARRAY(-38129, -23116)
HZWO	H	15	Z_ARRAY(-38103, -22664)
HZWO	H	17	Z_ARRAY(-37857, -22819)
HZWO	H	21	Z_ARRAY(-37651, -22638)
HZWO	H	25	Z_ARRAY(-37625, -22586)

etc.....

From this 3D right-volume table the topology structure (and geometry) of 3D right-volumes was obtained, representing the space to which the Ministry is entitled.

The 3D right-volumes give insight into the vertical dimension of the rights established (see figure 12.7 (a)). Now it is clear that the rights are established for an underground construction and not for a viaduct or a road. This solution also provides insight into the depth and height of the construction (if the height surfaces of parcels are also available), which is a considerable improvement of current registration.

The registration of a right for the tunnel will not take place, when the Ministry owns the intersecting parcel. This leads to ‘gaps’ in the 3D registration. This is clearly illustrated in figures 12.7 (b) and 12.7 (c). Figure 12.7 (b) shows the situation when new parcels are created and some of these parcels are in full ownership with the Ministry of Transport and Public Works. For those parcels a 3D right-volume will not be created (the Ministry owns the whole parcel column). The situation is even less clear in figure 12.7 (c). This will be the case when both new parcels and original parcels that are not divided are in full ownership of the Ministry.

Special cases are the parcels that are hold in bare ownership by the Ministry, while other persons are entitled to use space above and below the tunnel via limited real rights. In that case a 3D right-volume (multivolume object) would need to be maintained for the space above and below the tunnel. The representation of such ‘open’ 3D right-volumes would meet the same complications as the 3D right-volumes that refer to space ‘above street level’ in the Rijswijk case.

### 3D physical objects

Figure 12.8 shows the implementation of a physical object registration applied to the HSL tunnel. The spatial description of the whole tunnel is maintained as one 3D object in the database. Although the tunnel is a round shaped object which can easily be modelled in CAD software, implementing it in a DBMS reduces the precision of the data, since now the object needs to be approached by (many) flat polygons to be able to use the spatial primitives available in DBMSs.

The rights for the tunnel are still registered on the intersecting parcels. However, since the exact location of the tunnel is also maintained, it is not necessary to create new parcel boundaries. The holder of the tunnel is stored in the DBMS and is in this case the same as the subject who has a right of superficies or the right of ownership on the intersecting parcels. Note that in this case the safety zone is not included since



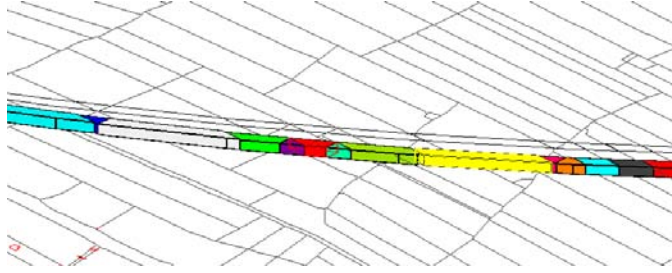

(a) All the parcels are encumbered by right of superficies, new parcels are created for all intersecting parcels

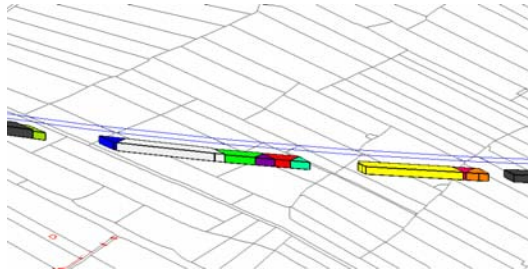

(b) As figure (a), but now three newly created parcels are in full ownership

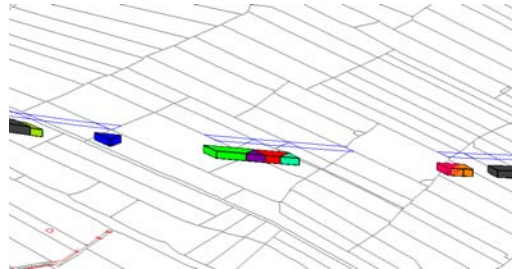

(c) Three newly created parcels are in full ownership, two parcels that are not subdivided are in full ownership. All the other (new) parcels are encumbered by a right of superficies

Figure 12.7: *Three possible recordings of 3D right-volumes in the case of a railway tunnel.*

the 3D representation relates to the actual construction. The location of the tunnel helps to better understand the real situation.

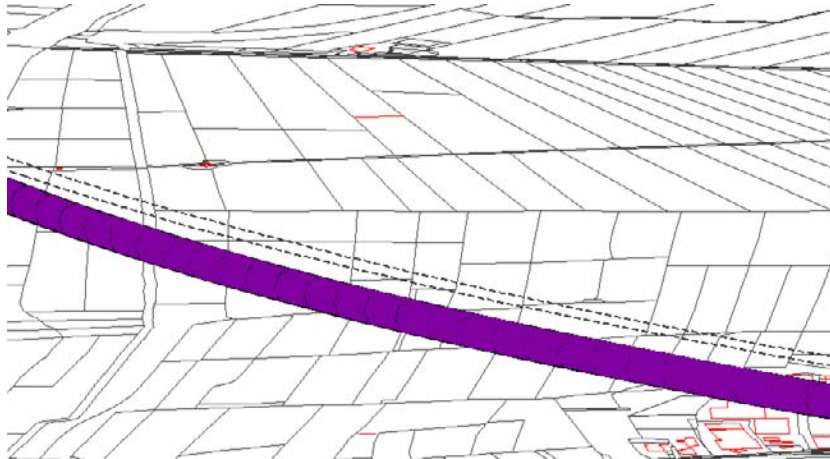

Figure 12.8: *Registration of the 3D physical object in the case of the HSL tunnel. The dashed line is the projection of the tunnel on the surface. Note that the parcels are not divided into smaller parcels.*

### 12.1.6 Evaluation of hybrid cadastre

When a juridical framework cannot entitle persons to volumes independent from the surface, the 3D cadastre can be implemented within a hybrid environment introducing either 3D right-volumes or a physical object registration.

#### 3D right-volumes

From the prototype implementations it can be concluded that the introduction of 3D right-volumes means a significant improvement of current cadastral registration in 3D situations. The inclusion of 3D right-volumes in the cadastral geographical data set provides an overview of the distribution of 3D property units. The registration warns the user of the cadastral registration that something is located under or above the surface. It also gives information on what is located under or above the surface (relationship with whole real estate object is maintained). For precise information the deed in the land registration can be consulted. A 3D survey of the situation can be made and used to describe the situation in the deeds and to determine the upper and lower limits of 3D right-volumes. From a technical point of view, the geometry of 3D right-volumes is simple and can therefore be maintained in the DBMS within current techniques.

Basic disadvantages of 3D right-volumes are:

- Since parcels are still the basis for registration, gaps can occur when no rights have been established that require a cadastral recording, e.g. when the holder of the construction is the same as the owner of the intersecting parcel. In these cases the location of the construction is still not known in the cadastral registration.
- If rights are established on just a part of a parcel, new parcel boundaries need to be created. This leads to fragmentation of both parcels and 3D right-volumes.

- When space where the right applies to is not precisely restricted in height or depth, registration of 3D right-volumes does not give satisfying insight, as was seen in the Rijswijk case. This could be solved by a rule applying to 3D surveys that will allow open polyhedrons (either not defined in height or in depth).
- Horizontal boundaries restrict the spatial description of 3D right-volumes. The concept of a 3D right-volume could be improved when other than just horizontal boundaries could be defined.

### Registration of 3D physical objects

From the experiments with the case studies it can be concluded that a registration of physical objects offers several improvements. The 3D description of the physical objects (extent of the object) can be used for reference purposes (to improve the reflection of the real situation) and to support cadastral tasks. When a 3D physical object is registered parcels do not need to be divided into parcels matching with the 2D projection of the physical object since the exact location of the physical object is known in the cadastral database. Only one object needs to be registered by which the registration for all intersecting parcels can be guaranteed. All parcels intersecting with the physical object can be found by a spatial query (by an overlay with the projection of the 3D object).

From a technical point of view the geometry that has to be maintained for physical objects can become complex. It is therefore not easy and straightforward to insert and maintain the spatial information on 3D physical objects within current techniques.

### Conclusion on hybrid cadastre

In both alternatives, rights to hold 3D property units are still registered on the intersecting parcels. Querying the legal status of 3D property units still needs to be done by querying the legal status of the intersecting parcels. However the maintenance of the 3D situation can assist considerably in understanding the real situation. Cadastral registrations that are not yet ready for a full 3D cadastre, will benefit for a number of reasons from a hybrid registration:

- The solutions give visual insight into 3D into the real situation. It is now clear from the cadastral registration that persons are entitled to space above or under the surface.
- Both solutions are implemented within the cadastral registration as part of the cadastral geographical data set and can therefore be queried with parcel surfaces in one integrated view.
- The proposed solutions show notaries how the inclusion of spatial information in deeds can be used to visualise the 3D component of rights in the cadastral registration. The solution can make notaries aware of the improvements of 3D registration and may motivate them to include well-defined 3D information in the deeds or to require a 3D survey plan.
- Registrations and databases outside the cadastral domain can benefit from the information on 3D situations that is available in the cadastral registration and vice versa via the Geo-Information Infrastructure (monument registration, building registration, taxes for immovable goods, management of soil pollution areas, management of cables and pipes, management of the subsurface).

The case studies were divided into building complexes and infrastructure objects. A physical object relating to a property unit within a building complex coincides with the legal space of a property unit. The main objective of cadastral registration in the case of building complexes is to give insight in property boundaries in all dimensions rather than to reflect the built constructions in the cadastral registration for reference purposes. On the other hand, the main objectives of a registration of 3D physical objects are firstly to be able to locate infrastructure objects to support cadastral tasks and secondly to register the person who holds an infrastructure object. Therefore the registration of 3D physical objects will specifically be suitable for infrastructure objects. For registering property units in building complexes, 3D right-volumes are more appropriate, because the spatial extent of property units can be easily and clearly defined with 3D right-volumes which refer to the legal space to which a person is entitled.

The two concepts of the hybrid cadastre (3D right-volumes and 3D physical object registration) have a different line of approach and therefore meet other needs of 3D cadastral registration. The 3D right-volume is a considerable improvement of insight into 3D property units as part of the cadastral geographical data set, while the 3D physical object registration provides information on constructions which is available in the cadastral geographical data set to improve the reflection of the real situation. The concepts could be combined to take advantage of both solutions.

The main limitation of both hybrid solutions is that the property rights are still related to surface parcels.

## 12.2 Prototype of the full 3D cadastre

In the full 3D cadastre it is possible to entitle a person to a volume parcel that is no longer related to the surface parcel (only in the case when it is subdivided from the infinite parcel column defined by the surface parcel). Section 12.2.1 will describe the results of the prototype applied to the case study in Queensland, while section 12.2.2 will evaluate the prototype of the full 3D cadastre.

### 12.2.1 The Gabba Stadium in Queensland

As was seen in section 4.6, the juridical framework in Queensland, as in some other countries and states, provides a good basis for a full 3D cadastre. Within this framework it is possible to establish property rights to 1) standard, infinite parcels, 2) volumetric parcels (no longer related to the surface) and 3) remainder parcels that are left after a volumetric parcel has been subtracted from a standard parcel. In our model volumetric parcels are referred to as ‘volume parcels’.

The cadastral framework in Queensland does not yet provide the possibility to maintain the 3D geometry of the volumetric parcels in the cadastral registration. In section 4.6 it was concluded that the current cadastral registration of volumetric properties, in which only the 2D geometry is registered, meets the following limitations:

- Since the 3D information is laid down on paper (or scanned) drawings (which is a 2D visualisation of 3D information), the 3D information cannot be interactively viewed.
- The 3D properties are only described by coordinates and faces on drawings, i.e. no 3D primitive is used. Therefore it is not possible to check if a valid 3D property has been established. Is the 3D property closed? Are the faces planar?
- The 3D information is not integrated with the cadastral map or with other 3D information, e.g. two or more neighbouring parcels cannot be visualised in one view in 3D and it is also not possible to check how volumetric parcels spatially interact in 3D (overlap, touch, etc.).

To improve cadastral registration we applied the feasible concept of the full 3D cadastre (combination of volume parcels and infinite parcel columns) to the described case study in Queensland; the Gabba Stadium in Brisbane at the location of Vulture Street (in the north), i.e. parcel 100 (stratum parcel) and parcel 101 (volumetric parcel), see figure 4.3 and 12.9.

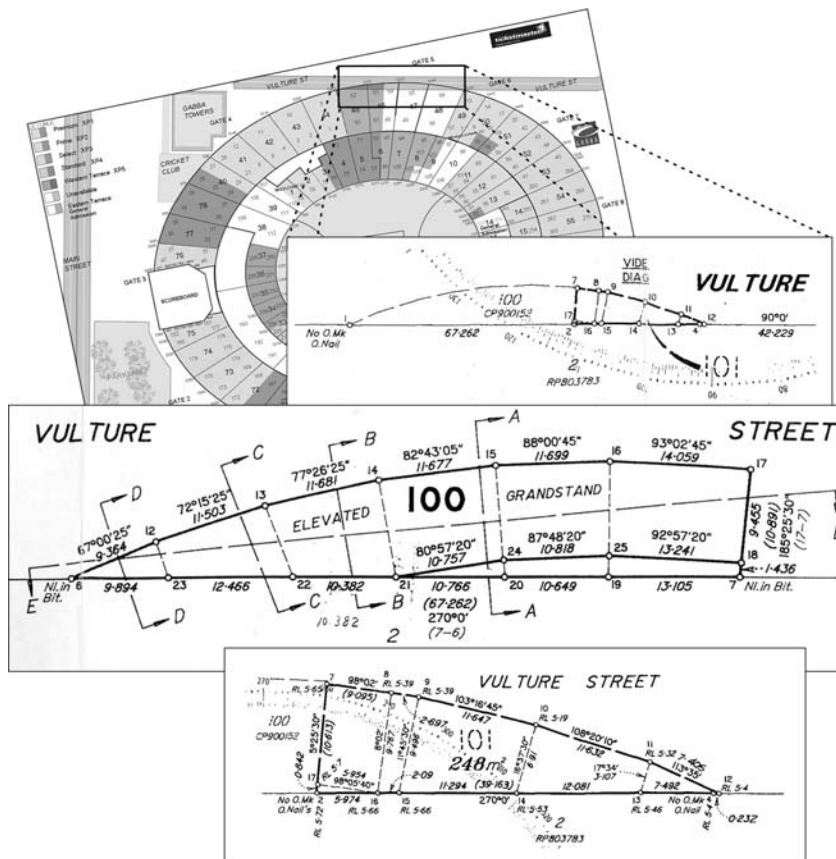

Figure 12.9: Volumetric parcel (101) and stratum parcel (100) used in the case study.

The required survey plans for the volumetric parcel and the stratum parcel contain 3D information that can be used to describe the 3D geometry and the 3D topological structure of these objects in the cadastral database. The following steps were followed to convert the spatial information on the (scanned) 3D survey plans into a 3D geometrical primitive in the DBMS:

- The field measurements, as indicated on the survey plan by distances and bearings between the successive points, were adjusted by traverse adjustment for each parcel in a local coordinate system [209].
- The local rectangular coordinates are fitted to the (global) map coordinates by an over determined conformal (Helmert) transformation using three connections points in both coordinate systems [209].
- The faces were constructed with references to nodes.
- This information was inserted in a 3D topological structure (SSM) in the DBMS.
- From the topological structure the geometry (as polyhedron primitive) can be realised, validated and (spatially) queried using the self-implemented 3D primitive and 3D functions.

After these steps the 3D geometries could be visualised and queried in one integrated view (see figure 12.10), which offers major improvements. It is now possible to see if and how the volumetric parcels interact and to view the 3D situation interactively.

The neighbouring polygons as defined do not match face to face; comparing the common boundary between parcel 100 and 101 shows a difference of about 30 centimetres (see figure 12.10 (b)).

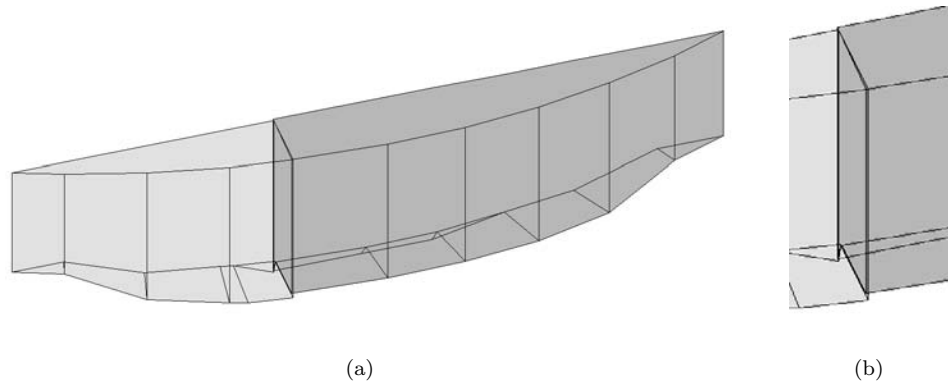

Figure 12.10: *Visualisation of 3D geometries of volumetric parcels, stored in DBMS. Zoom-in on shared faces (b) shows that the shared faces do not coincide.*

This may indicate an error but in this case it is correct. The two parts were determined at different times, and parcel 101 allows more space around the structure. The measurements define the space while there is no real object to mark the limits of the parcels. Therefore the geometry of the volume parcels must by definition be correct.

In order to validate the volumetric parcels and to perform 3D spatial functions on the volumetric parcels, the geometry of the volumetric parcels was represented using the self-implemented 3D geometrical primitive (section 7.4).

Therefore we were able to query the 3D objects in an integrated DBMS environment:

```

/* validate of 3D geometries */
SELECT bid, validate_polyhedron(return_polyhedron(shape), 0.5) validate
FROM qld_3Dgeom;

BID    VALIDATE
-----
100    True
101    True

/* calculate volumes of 3D geometries
SELECT bid, volume(return_polyhedron(shape)) volume
FROM qld_3Dgeom;

BID    VOLUME
-----
100    12725.1989
101    5329.18583

/* check if two geometries intersect (1=TRUE and 0=FALSE) */
SELECT d1.bid, d2.bid FROM robject3dql d1, robject3dql d2
WHERE intersection(return_polyhedron(d1.shape), return_polyhedron(d2.shape),0.01) = 1
AND d1.bid < d2.bid;

BID      BID
-----
100      101

```

The 3D geometries can be incorporated in a cadastral geographical data set that contains surface parcels represented in 2.5D in order to get a 3D overview of the complete situation. For this purpose a conforming TIN was generated using ESRI software that incorporated the planar partition of the cadastral base map (see chapter 9). The result is shown in figure 12.11.

### 12.2.2 Evaluation of full 3D cadastre

As can be concluded from this case study, the full 3D cadastre offers many improvements compared to traditional cadastral registrations:

- The real situation is no longer projected on the surface, i.e. volumetric parcels are not dominated by the parcel pattern on the surface.
- Persons can be entitled to space in a transparent way instead of establishing property rights on intersecting parcels to establish the legal status above and below the surface.
- The space is precisely described in a 3D survey document, which offers a uniform way of defining 3D property units.

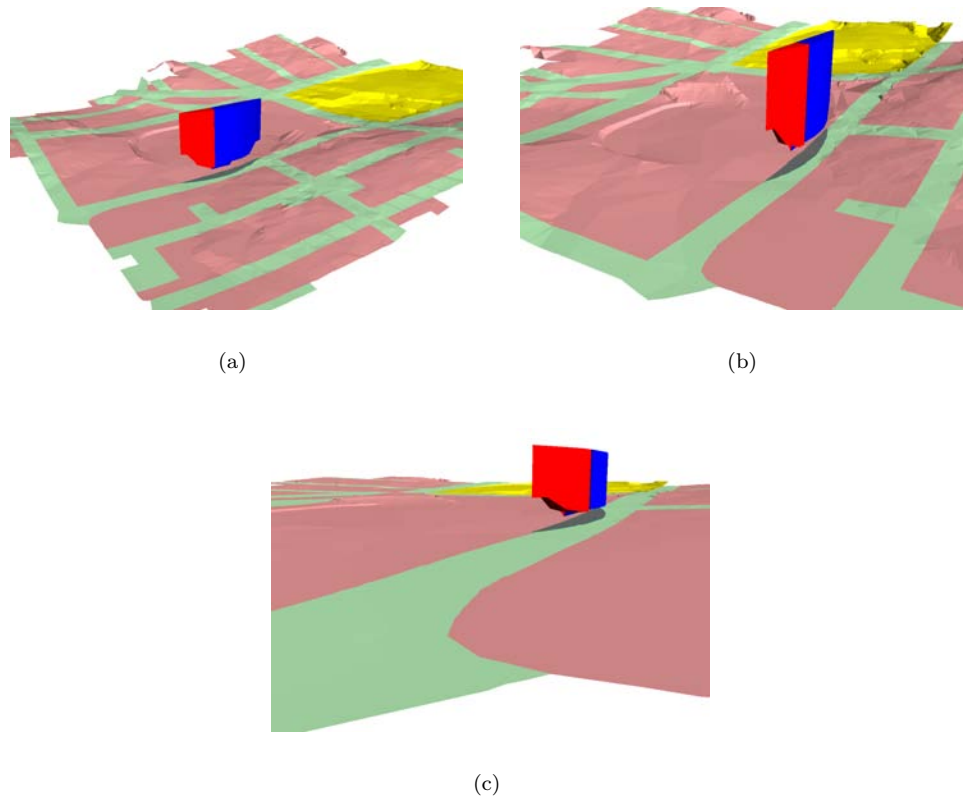

Figure 12.11: *Visualisation of 3D geometries of volumetric parcels together with the 2.5D cadastral base map, seen from different view points.*

The full 3D cadastre also offers improvements in countries and states that already establish 3D property units unrelated to the surface:

- The information from the 3D survey document can be used to insert the volume parcels in a topological structure and in geometrical primitives in the DBMS.
- The volume parcels can be viewed interactively.
- The geometry of volume parcels can be checked, e.g. are the faces planar, is the volume closed, are there no self-intersections?
- The 3D situation can be (spatially) queried in the DBMS (e.g. do volume parcels intersect?).
- The volume parcels can be visualised in an integrated view with a 2.5D representation of the parcels that are defined by parcel boundaries on the surface.
- The volume parcels and the 2.5D surface parcels can be queried in the DBMS, e.g. is the volume parcel located above or below the surface, or does it intersect the surface?



The advantage of having the 3D property unit in the same environment as the 2D parcels clearly offers great potentials. However, even starting from one of the more advanced environments (Queensland, where both the legal aspects and the 3D survey documents are satisfactory dealt with) quite a number of non-trivial issues still need to be addressed:

- In the survey plans both the 3D points and edges are specified (as required), however there is no explicit listing of faces and the polyhedron itself. It is not trivial to reconstruct the faces and it is possibly ambiguous, especially in more complex cases (such as parcel 103 in figure 4.3).
- The validation of the polyhedron is non-trivial (especially if it consists of other faces than horizontal, vertical or triangular faces). Is the volume completely closed? Are all the faces planar (enough)? Is the orientation correct? Are holes or cavities modelled correctly? etc.
- The (footprints of the) 3D objects do not fit perfectly in the cadastral map: a straightforward conversion from the local coordinates to global coordinates (rotate, translate) resulted in a mismatch of about 60 cm: additional field measurements are required to solve these differences.
- The Queensland regulations also allow non-polyhedral 3D objects, such as (rotated) ellipsoids or cylindrical patches (see figure 12.12). Should these be converted to polyhedrons (approximation within given tolerance) to be modelled in the DBMS or should the DBMS be extended with complex 3D data types?
- Attention should be paid on how to make sure that two polyhedra do not overlap in 3D space (but at most touch in a common node, edge or face) and on how to make sure that there is no 3D sliver between two polyhedra that are supposed to be touching neighbours.
- The cadastral registration should be organised in a uniform manner. In the case study (with only three 3D objects all related to the same construction) some differences are noticeable:
  - Neighbour parcels 100 and 101 are both on the same side of the stadium, but parcel 100 is related to a stratum parcel, since it was established before 1997, and parcel 101 is related to a 3D volumetric parcel, which is only possible after 1997. Therefore the available information for the parcels differs.
  - Parcels 101 and 103 are both volumetric parcels, while parcel 101 is relatively rough, it seems that parcel 103 is defined quite tightly around the construction (making this object quite complex).
- Trivial registration errors should be avoided, such as the recording of the volume. It turned out that the recorded volume of parcel 101 in the cadastral registration was not correct (10,000 times too large), probably due to some typing error (because the survey plan was correct).

In addition to this, it is also a challenging task to integrate a terrain elevation model with the 2D surface parcels in order to obtain 2.5D surface parcels which can be combined with the 3D objects. This should preferably be implemented as an integrated view (in the DBMS sense) on the two data sets from the independent, distributed sources and not as a physical (permanent) integration with copies of the data sets (see chapter 9).

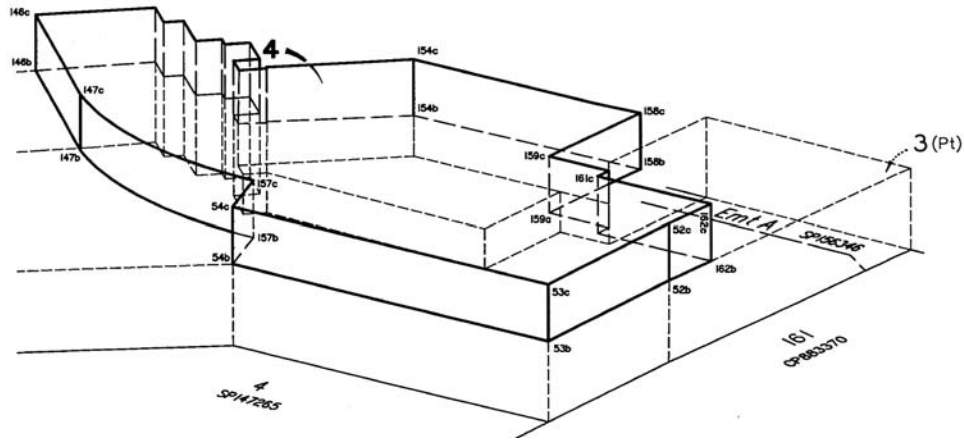

Figure 12.12: *Volumetric parcel defined with more complex geometry than polyhedron.*

In areas with high density of 3D volume parcels a true space partitioning might be needed (defined in a full topological model).

## 12.3 Conclusions

In this chapter the concepts of the hybrid cadastre and the full 3D cadastre were applied to case studies in order to evaluate the concepts.

### Hybrid cadastre

#### *3D right-volumes*

The experiments with the case studies showed that 3D right-volumes considerably improve insight into the property situation in 3D property situations. It is now clear how property units are distributed in 3D. Generating and maintaining spatial data is easy when registering 3D right-volumes: the parcel boundaries that are already registered form the basis for the 3D representations while the geometry of 3D right-volumes is simple. A disadvantage of 3D right-volumes is when no limited rights have been established on a parcel in a 3D situation. These cases are not registered in the cadastral registration and therefore they lead to gaps in the 3D registration. Another disadvantage is when rights are not clearly restricted in the vertical dimension in the deed. In the first case, gaps occur in the registration and in the second case the 3D right-volume does not necessarily yield more insight than in current cadastral registration as was seen in the Rijswijk case. In the case of apartment units, the 2D boundary of 3D right-volumes did not coincide with the parcel boundary. However if drawings added to deeds of divisions would be available in vector format and in world-coordinates the spatial information from the drawings can be used to automatically produce the 2D description of 3D right-volumes for every floor. These polygons can then be used to generate the 3D right-volumes. The 3D right-volume concept could be improved if the boundaries between two 3D right-volumes on top of each other were not restricted to horizontal boundaries. Non-horizontal boundary can reflect

more detail.

### *3D physical object registration*

The experiments with the case studies showed that the availability of physical objects in the cadastral geographical data set offers better means to reflect the real situation. In addition, parcels need no longer to be divided into parcels that match the 3D objects and ‘gaps’ in the cadastral registration can easily be traced. Technical issues have to be solved to be able to maintain the complex geometry of physical objects in the cadastral DBMS. The geometries of physical objects will (mostly) have to be provided by third parties.

As can be concluded from the experiments in this case study the registration of 3D physical objects is specifically suitable for infrastructure objects, while the 3D right-volumes are more appropriate for registering property units in building complexes.

The two concepts of the hybrid cadastre (3D right-volumes and 3D physical object registration) have a different line of approach and therefore meet other needs of 3D cadastral registration. The concepts could be combined to take advantages of both solutions. The disadvantage of both hybrid solutions is that the rights to real estate are still related to land and not to volumes.

### **Full 3D cadastre**

In the full 3D cadastre volume parcels can be established that no longer have a relationship with surface parcels. This concept was applied to the Gabba Stadium case study in Queensland, Australia. The juridical framework in Queensland already provides the possibility to establish volumetric parcels as in the Gabba Stadium case, however the cadastral framework does not provide the possibility to incorporate the (precisely) defined volumetric parcels as part of the cadastral geographical data set in 3D. The prototype applied to this case study showed that it is possible to use the 3D information from the 3D survey plans (needed to establish volumetric parcels) to insert the 3D geometrical and topological characteristics in the DBMS. This makes it possible to validate the volumetric parcels, to perform 3D functions on these parcels and to query and visualise the 3D situation in one integrated view containing volumetric parcels and 2.5D surfaces of standard and remainder parcels. The prototype of the full 3D cadastre showed the very good potentials of a full 3D cadastre since insight into the 3D situation is considerably improved, while the concept is based on an integrated approach of the juridical aspects (to allow volume parcels), cadastral aspects (to register volume parcels) and technical aspects (to define volume parcels in 3D survey documents and to incorporate this information in the cadastral database, followed by an integration of volume parcels and a 2.5D surface of the base map).

From the experiments with the case study in Queensland it can be concluded that, though the states and countries that already establish 3D property units have some remarkable differences (some require real constructions to be related to the 3D property registration others not, some limit the 3D property to be within the column of one surface parcel others not, some require quite detailed 3D survey plans to support the 3D property registration others not), they all can be supported by a cadastral registration based on the proposed full 3D cadastre model, although there are some non-trivial aspects (in the conversion and use of a 3D cadastre), which require further attention.

An important condition of the full 3D cadastre is that the juridical system is flexible enough to permit volume parcels. In other 3D cases the hybrid solution can be considered to improve traditional cadastral registration.

## Chapter 13

# Summary, conclusions and further research

The main research question of this thesis was “how to record 3D situations in cadastral registration in order to improve insight into 3D property situations”. This thesis used the cadastral registration in the Netherlands as starting point, although also cadastral registrations abroad were examined. To answer the main research question, this research was divided into four major parts. This chapter summarises these parts and lists the main conclusions that can be drawn from the four parts:

- Analysis of the background (section 13.1).
- Technical framework for modelling 2D and 3D situations (section 13.2).
- Models for a 3D cadastre (section 13.3).
- Realisation of a 3D cadastre (section 13.4).

Based on the conclusions recommendations for future directions and future research can be outlined. Section 13.5 contains recommendations for future directions towards a 3D cadastral registration in the Netherlands. Section 13.6 lists the recommendations for future research.

This chapter ends with summarising the most important results of this research.

### 13.1 Analysis of the background

In the analysis of the background the cadastral registration of 3D property units in the Netherlands as well as abroad were studied in order to get a clear overview of the requirements, the constraints and the state-of-the-art of 3D cadastral registration. In section 13.1.1 current practise of establishing and recording rights and restrictions in 3D property situations in the cadastral registration are summarised as well as the basic limitations. Section 13.1.2 contains the juridical and cadastral constraints for a 3D cadastre that are imposed by the Dutch juridical and cadastral framework. From

the limitations and constraints the basic needs and requirements for a 3D cadastre in the Netherlands are summarised in section 13.1.3.

### **13.1.1 Current registration practise of 3D property units**

From the survey in part I of this thesis the following conclusions can be drawn on the current status of cadastral registration in case of 3D property units.

#### **Establishing the legal status of 3D property units in the Netherlands**

In the Netherlands, property to space is related to and dependent on the property of surface parcels. Persons can only be entitled to 3D property units by establishing rights and limited rights on intersecting surface parcels. The basic drawback of the land (surface) oriented concept of property rights to real estate, is that the 3D reality in which persons are entitled to volumes is projected on the surface.

#### **3D property units in the Dutch land registration**

The deeds concerning real estate archived in the land registration (Public Registers) must always relate to land parcels. In the deeds it is possible to precisely define the space to which the concerning rights apply, for example by adding an analogue cross section. Basic drawbacks of current land registration is that 3D property units are not known as individual property units in the land registration, except in the case of apartment rights. In addition, it depends very much on the choices in the notarial deed and we may assume also on the legal advice of the notary (in the Netherlands a publicly appointed official charged with drawing up authentic deeds and legalising documents) how the legal status in 3D situations is established (what rights are used, are parcels subdivided) and also what information is added to the deeds. In general, there are no instructions for a 3D survey that could be added to a deed. Only in case of apartment rights an analogue drawing is obliged containing an overview of every floor (assuming that there are clearly identifiable floors) and only in case of apartment units there are special requirements concerning the quality of the spatial information. Apartment rights are also always related to one or several surface parcel(s).

#### **3D property units in Dutch cadastral registration**

The surface parcel is always the entrance to a cadastral recording. Only in the case of apartment rights individual 3D property units are known as such in the administrative part of the cadastral registration. The 2D parcel as basic (and only) real estate object in the cadastral registration meets several drawbacks. The legal status of space above and below the surface can only be obtained by collecting information on the legal status of intersecting surface parcels. However, one first has to find out which parcels intersect with the 3D construction. This is not always an easy query since the construction itself is not available in the cadastral registration. In addition, more than two million cadastral recordings were found in the cadastral database of September 2003 that could indicate a 3D situation (cases in which than more than one person has interest in the same parcel column). The third dimension of rights and restrictions of these recordings cannot be reflected in the cadastral registration, even if this information is available in deeds, drawings or survey plans. Consequently the current cadastral registration provides information on which persons have a right on a parcel but not on the spatial extent of these rights. Access to information in 3D property situations will soon be improved, since deeds and drawings archived in the

land registration will be accessible in scanned format through the cadastral database in the near future, although this still will be limited to querying the information per parcel, instead of visualising the 3D situation of several parcels in one environment (similar as viewing the current cadastral map).

#### **Content of the Dutch cadastral geographical data set**

The cadastral geographical data set is 2D and contains parcel boundaries and buildings for reference purposes. The (footprint of) apartment units, constructions and phenomena such as soil pollution and monuments are not included in the cadastral geographical data set. Underground constructions and telecom-networks could be mapped in the topographic part of the cadastral database (which is not part of the cadastral map) by using a specific visibility and classification code. Drawback of the current cadastral geographical data set is that first of all no 3D overview can be provided of a 3D property situation. However also footprints of 3D property units are not drawn on the cadastral map. In addition, the current topographic part of LKI (September 2003) does not contain transport systems or telecom-networks (although it does contain pipelines). Consequently, the real situation is not sufficiently reflected in and cannot clearly be obtained from the cadastral geographical data set.

#### **Establishing the legal status of 3D property units abroad**

The developments on 3D cadastral registration depend on the national legal system, on the type of cadastral registration as well as on the state-of-the-art of the cadastral registration (see chapter 2). The solutions abroad establishing the legal status of 3D situations use either the strict definition of ownership and property rights that is always related to surface parcels as in the Netherlands (e.g. Denmark and Israel), or are based on a more advanced concept of the right of ownership and other property rights that is no longer always related to surface parcels but can be related to volumes. The countries that use the strict definition of ownership and property rights meet basically the same drawbacks as cadastral registration in the Netherlands. The solutions that no longer relate ownership and property rights to surface parcels were found within juridical frameworks that are able (or were able after some minor adjustments) to establish multilevel ownership, e.g. ‘volumetric parcels’ in Queensland, ‘air-space parcels’ in British Columbia and ‘construction properties’ in Norway and Sweden. These solutions to establish volume parcels differ per country, e.g. the footprints of 3D property units should be within the 2D surface parcels (British Columbia) or not (Norway, Sweden, Queensland), the 3D property units have to relate to built constructions (Norway, Sweden) or not (British Columbia, Queensland), the 3D property units have to be described in survey plans (British Columbia, Queensland) or not (Norway, Sweden). From these new solutions it can be concluded that within some juridical frameworks it is possible to explicitly entitle persons to volumes, which is an important precondition for a well-working 3D cadastral registration. The establishment of 3D property units that are no longer related to surface parcels provide better means to reflect the real property situation.

#### **3D property units in cadastral registrations abroad**

Although the 3D property units can be established within the juridical framework in Queensland, British Columbia, Norway and Sweden and registered in the land registration and cadastral registration as individual property units, none of these solutions include a complete 3D cadastral registration of 3D property units. This

causes a few problems. Firstly, a digital description of the 3D property unit in vector format is not maintained in the land registration (only scanned or paper drawings). Therefore the 3D property unit cannot be viewed interactively and the geometry of the 3D property unit cannot be validated. Secondly, the 3D properties are still not incorporated in 3D in the geographical data set of the cadastral registration (only as footprints), by which it is not possible to query and view the 3D situation in the cadastral registration. These solutions therefore do not address technical issues, such as how to store, query and visualise 3D property objects (in 3D) and how to make sure that 3D properties do not overlap (the condition that 2D parcels may not overlap assures complete and consistent registration in current cadastral registrations).

### 13.1.2 Cadastral and juridical constraints for a 3D cadastre

Important condition of this research is that the proposed 3D cadastre has to fit to some extent within the Dutch juridical and cadastral framework and should be technologically possible. These conditions impose constraints on a 3D cadastre. The background analysis yielded insight into the cadastral and the juridical constraints as will be described in this section (the technical constraints were studied in part II: framework for modelling 2D and 3D situations, see section 13.2).

#### **Juridical constraints**

Juridical constraints, defined by the juridical framework, are dependent on the juridical doctrine and the history of the legal system in a specific country. For example in some countries the juridical framework provides the possibility to establish multi-level ownership while in other countries this is juridically impossible. The juridical constraints for a 3D cadastre in the Netherlands can be summarised as follows:

- The legal status to real estate is always established on 2D surface parcels and is (until now) land (surface) oriented.
- Right of property to a parcel is undefined in the vertical dimension (reaches as high or as low as a user has interests).
- Horizontal division of ownership is only explicitly and juridically possible by a right of superficies or an apartment right (the establishment of these rights is not accompanied with a 3D survey).
- Other limited real rights can be used to establish a factual horizontal division in ownership by describing explicit and precise limitations of the right in the concerning deed.

#### **Cadastral constraints**

Cadastral institutions, cadastral rules and cadastral instruments also lay down constraints upon cadastral registration, although the cadastral framework is more flexible (easier to adjust) than the juridical framework. For a 3D cadastre in the Netherlands, the important cadastral constraints are:

- The current cadastral geographical data set is 2D. For a 3D cadastre, the cadastral geographical data set needs to contain both 3D information on 3D property units and parcels that are draped over a height surface in one environment.
- The Dutch cadastral institution cannot enforce rules on how to register. If the information in the deed is correct, it has to be registered in the cadastral



registration, even if there would be better possibilities to establish and register the legal status of the situation. Also requirements on the quality of the spatial information cannot be imposed, e.g. a soil pollution area on a drawing vaguely indicated by the notary is allowed. Only in the case of apartment drawings specific requirements concerning the quality and content of the drawings are imposed.

- An important question is who will finance (and organise) the 3D cadastral registration, including maintenance of the registration. This will be either the Kadaster in case the government makes the Kadaster responsible for 3D cadastral registration or the persons who benefit from the registration (e.g. holders of physical objects, but also managers and planners who query the 3D registration). Financing of a 3D registration should be supported by good organisation and legislation. In general the benefits should be larger than the costs. Also 3D registration should be cost-recovery at large.
- The cadastral registration should be connected to the Geo-Information Infrastructure (GII). In that case a 3D cadastral registration can benefit from spatial (3D) information that is maintained by other organisations and in other databases and vice versa, since information can easily be shared. Furthermore within a GII, the cadastral registration is much easier accessible for users.

### 13.1.3 Needs and requirements for a 3D cadastre

Based on the description of current cadastral registration in case of 3D property units and the constraints of the cadastral and juridical framework in the Netherlands, the basic needs for a Dutch 3D cadastre, focusing on improving insight into 3D situations, can be summarised as follows:

- to have a complete registration of 3D rights as such (rights which entitle persons to volumes). The current cadastre already registers rights which entitle persons to volumes, e.g. full ownership (applies to whole parcel column), right of superficies etc., however a 3D cadastre should explicitly register the space to which rights apply;
- to have good accessibility on the legal status of 3D property units including (3D) spatial information as well as on Public Law restrictions.

It will be more effective (e.g. with respect to data integrity and data consistency) if information on constructions and other objects of interest is maintained at their source (e.g. in databases of holders of constructions) and accessible within and from the 3D cadastre within a GII.

Based on these considerations, we can conclude that a 3D cadastre should incorporate the following functionalities:

- register 3D information on rights (what is the space to which the person is entitled?) and make this information available in a straightforward way;
- establish and manage a link with external databases that contain objects that are of interest for the cadastre (infrastructure objects, soil pollution areas, forest protection zones);

- use the information on these objects to support registration tasks, i.e. to detect and correct errors in cadastral registration or in the process of registering and viewing the legal status of 3D property. Are all intersecting parcels encumbered with a right for the infrastructure object?

## 13.2 Framework for modelling 2D and 3D situations

The 3D cadastre needs to be implemented using current and new techniques. The framework of modelling 2D and 3D situations was studied in part II of this thesis. In chapter 6 it was concluded that DBMS plays an important role in the new generation GIS architecture. Consequently to implement the 3D cadastre, in which a lot of information needs to be managed, a DBMS is needed for maintaining the cadastral (spatial and non-spatial) information concerning 3D situations.

Fitting this research in a technical framework required a study to what is technically possible with respect to maintaining, accessing and analysing 3D geo-information in DBMSs using standard products and additional developments. Current technologies were tested and concepts were designed and implemented into prototypes to improve current technology.

In section 13.2.1 the conclusions on possibilities of support of spatial data types in geo-DBMSs are drawn. Apart from geo-DBMS other developments of 3D GIS are important for the 3D cadastre research, since available 3D GIS functionalities in general impose constraints and provide possibilities on how to maintain, access and analyse 3D geo-information. In section 13.2.2 the state-of-the-art of 3D GIS is summarised. How to access spatial information stored in a DBMS with different front-ends (as the new generation GIS architecture is organised) is described in section 13.2.3. Finally, in section 13.2.4 the possibilities and problems of combining 2D and 3D geo-objects in one environment are described.

### 13.2.1 2D and 3D geo-objects in geo-DBMS

The 3D spatial component of constructions and rights, but also of parcels, has to be registered in the cadastral database. This raises the question how to structure spatial objects in 2D and 3D in a DBMS. Concerning this, the following conclusions can be drawn.

#### **2D and 3D geometrical primitives in DBMS**

Geometrical primitives as defined by the OpenGIS Consortium (OGC) have been adapted by mainstream DBMSs and popular non-commercial DBMSs. The OpenGIS Implementation Specification for SQL [148], is until now 2D. It also does not cover topological structure, although topological relationships can be obtained by spatial functions on the geometrical primitives. The ISO DIS 19107 standard [87] (adopted as Abstract Specification by OGC) does define 3D spatial objects and topological structure, however these Abstract Specifications still have to be transformed into Implementation Specifications by OGC and to be adopted by DBMSs.

Current DBMSs do not support 3D volumetric data types. To maintain 3D geometrically structured data within current techniques, 2D primitives defined in 3D embedding space can be used (polygon defined in 3D). 3D objects can be defined either as a body that consists of a set of faces or as a multipolygon defined in 3D. However, these 3D objects are not recognised as such by DBMSs or only in a limited way (e.g. to calculate the 3D length of a line). The z-coordinates are stored while in nearly all spatial analyses and validation checks the 3D object is projected on the surface. To support true 3D in a DBMS, a 3D geometrical primitive (polyhedron) has been defined and implemented in the DBMS as part of this research. Using this primitive 3D geometries can be defined consisting of flat faces including holes. This implementation shows the possibilities of maintaining 3D objects in a geometrical structure. As part of the implementation 3D spatial functions and a 3D validation function were implemented.

### **2D and 3D topological structures in the DBMS**

Awaiting an Implementation Specification for 2D (and 3D) topological structure, there are already some user-defined (section 7.2.2) and commercial implementations of 2D topological structures available (Laser-Scan, see section 7.2.3, and Oracle 10g). These implementations look promising when applying topological queries on the structures (good performance). However geometrical queries are faster on the geometrical primitives since many tables need to be queried to get a geometrical realisation of the topological structure before the geometrical query can be executed. At the moment topological structure is therefore mainly appropriate for representing relationship operations and for checking the quality of the data. The topology structure offers better maintenance possibilities with respect to quality. Topological structure supports consistency of spatial data since shared lower-dimensional objects are stored only once, in contrast to data defined with geometrical primitives. Topological structure management to maintain 3D geo-objects and 2D geo-objects for the 3D cadastre is preferred, but, as can be concluded from this thesis, has to be implemented using self-defined extensions.

We experimented with a DBMS implementation of a 3D topological structure: SSM (Simplified Spatial Model) which is a topological structure described in [240]. This topological structure only supports flat faces (as the implemented polyhedron primitive). In an object relational DBMS, the relationships between the high-dimensional (3D body) and low-dimensional objects (FACE and NODE) can be stored. The implementation shows that storing a 3D object and generating a geometrical realisation of the 3D object within the DBMS is not a problem. However since the topological structure is not recognised by the DBMS, topological consistency has to be checked and guaranteed outside the DBMS, available spatial indexing cannot be used and spatial functions have to be self-defined (intersection, distance).

Summarising, the 2D geometrical primitive (including spatial operations) is well implemented in DBMSs, support for topological structure in 2D in DBMSs just started but will most probably be available in DBMSs within a few years, while none of the DBMSs have started with support for 3D volumetric objects (either using geometrical primitives or topological structure). Also the OpenGIS Consortium still has to decide on Implementation Specifications for a geometrical and a topological schema in 3D. Therefore the 3D cadastre will have to be based on a combination of commercial

products and user-defined extensions which showed potentials in the experiments in this research.

### 13.2.2 3D GIS

In chapter 8 an extended overview was given concerning other basic aspects (apart from DBMS aspects) of 3D GIS: organisation of 3D data, 3D data collection and object reconstruction, visualisation and navigation in 3D environments and 3D analysing and 3D editing. Based on this overview it can be concluded that 3D GIS still has to mature. 3D GIS developments are mainly in the area of visualisation and animation. Bottlenecks for commercial implementation of 3D GIS are:

- 3D editing in GIS is not (yet) possible and is traditionally a functionality that is well supported in CAD software but not in GIS;
- poor linkage between CAD, traditionally designers of 3D models, and GIS;
- lack of methods to automatically reconstruct 3D objects;
- visualisation of 3D information requires special techniques; characteristics such as physical properties of objects (texture, material, colour), behaviour (e.g. on-click-open) and different levels of detail representations need to be maintained and organised in DBMSs;
- Virtual Reality and Augmented Reality techniques should be incorporated in GIS software to improve interaction with and visualisation of 3D environments.

### 13.2.3 Accessing spatial information organised in a DBMS

Once 3D geo-objects are stored in a DBMS within current techniques, the next issue is how to access and query the geo-objects by front-ends. Three front-ends were analysed to access 3D objects stored in (3D) geometrical primitives in Oracle Spatial 9i: a CAD oriented front-end, a GIS front-end and a self-developed front-end using Web based techniques.

#### **CAD oriented front-end**

With the CAD oriented software MicroStation GeoGraphics (MS GG) it is rather easy to visualise 3D objects stored as multipolygons in a DBMS, however querying and editing 3D objects require more complex steps but it is possible while true 3D editing is supported in MS GG. The main disadvantage is that the database structure is altered. The Java applet 'Spatial Viewer' that is delivered with MicroStation GeoGraphics requires less customisation and is therefore easier to use.

#### **GIS oriented front-end**

To be able to access a spatial layer stored in Oracle Spatial with the GIS front-end 'ArcGIS', one first needs to register the spatial layer with ArcSDE. After registering the spatial layer, querying of spatial objects is, apart from some small problems, straightforward and the tables structure is not altered. One major complexity of ESRI is that ArcSDE validates spatial objects before they are inserted into ArcGIS. This means that spatial layers containing invalid spatial objects cause problems. The main consequence of not being able to handle invalid objects, is that 'vertical' polygons

(polygons perpendicular to the surface) cannot be visualised in ArcScene, although ArcScene does support vertical polygons when they are stored in other formats. It should be emphasised that ESRI, as other GIS software, does not offer (graphical) functionality to edit in 3D and to perform spatial analyses in 3D.

Both MicroStation GeoGraphics and ArcGIS are specifically based on Oracle Spatial 9i, which is not fully OGC compliant. MicroStation GeoGraphics and ArcSDE also support other DBMSs. However all combinations (front-end combined with back-end) have their own architecture. If both the DBMS and the front-end would be fully OGC compliant it should be possible to query any DBMS that support OGC geometries with any front-end that is based on OGC specifications.

### **Web based front-end**

In order to look for a more open solution in sense of interoperability but also in sense of open source, a prototype was built using Web based techniques. Internet has become a major tool for disseminating information in today's society in which information has gained a crucial place. We studied the use of Web technologies that were designed outside the GIS world. These techniques included Internet formats for displaying and querying 3D objects and techniques to query a DBMS via the Internet. Based on these techniques two prototypes were built. The experiences with the prototypes showed that it is possible to view and query 2D and 3D geo-objects that are stored in a DBMS using open source Web technology. Although Oracle is used as back-end, the prototype that looks most promising uses an XSQL servlet which also works on other DBMSs provided these DBMSs can be accessed via JDBC connections.

To make the prototype OGC compliant, we studied the possibilities to use the OGC Web Services. OGC has defined several OGC Web Services, that can be used to disseminate 3D information via the Internet: Web Map Service [153], Web Feature Service [154], Web Terrain Service [149] and Web Coverage Service [158]. Navigation, querying and identifying 3D geo-objects requires a 3D vector representation of 3D objects, which is only offered by the Web Feature Service (WFS) that returns geo-information in GML (Geography Markup Language). GML 3.0 [155] includes the ability to handle complex properties, to describe coordinates with x,y and z (already possible in version 1 and 2) and to define 3D objects. With the WFS it is also possible to edit 3D objects via the Internet.

### **13.2.4 2D parcels and 3D geo-objects in one 3D environment**

When integrating 3D geo-objects and 2D parcels in one environment, the height issue needs to be addressed: how to locate the 3D geo-objects with respect to 2D surface parcels in one 3D view. Basically there are two solutions for this:

- z-coordinates of 3D geo-objects are stored within a national reference system
- z-coordinates of 3D geo-objects are stored relative to the surface

The most sustainable solution is to define 3D objects with absolute z coordinates within a national reference system. Firstly because absolute z-coordinates are not influenced by surface changes. Secondly, the definition of the surface level (the reference level used for values with respect to the surface) is sometimes not clear. Finally when

using z-coordinates with respect to the surface it is complicated to define the actual geometry of 3D objects. Having 3D objects defined in absolute values, the next issue is how to combine the 3D objects with parcels defined in 2D. For this purpose the parcels need to be draped over a height surface. A case study was carried out using a DBMS approach in which laserscan data (point heights) on a density of one point per 16 square meters was integrated with parcel boundaries in order to be able to extract height surfaces of individual parcels. TINs (Triangular Irregular Networks) representing height models were created outside the DBMS because TINs are not (yet) supported within DBMSs. The planar partition of 2D parcels was included in the TINs.

Main conclusions that can be drawn from this case study are:

- Incorporating the planar partition of parcels into a height surface makes it possible to extract the 2.5D surfaces of parcels and to visualise the 2D cadastral geographical data set in a 3D environment.
- It is not easy and straightforward to create a good integrated elevation and object model. Several alternatives of a TIN structure were investigated: unconstrained Delaunay TIN, constrained TIN, conforming TIN, and finally refined constrained TIN. After some analyses, the refined constrained TIN, was selected as most appropriate for the purpose of this research.

The large data volume as a result of a dense laseraltimetry data set led to poor performance, while not all point heights significantly contribute to the height surface. Therefore a generalisation method was described to come to an effective model of parcel surfaces. The first part of this generalisation method was implemented and applied to a study area. From these experiences it can be concluded that an initial filtering of the point heights results in a much improved integrated model: about 4 times less points, but still within the epsilon tolerance of the same size as the quality of the original input data sets.

## 13.3 Models for a 3D cadastre

In part III of this thesis, conceptual models and logical models for a 3D cadastral registration were developed in order to meet the cadastral and technical requirements for a 3D cadastre that were studied in part I and part II of this thesis.

### 13.3.1 Conceptual solutions for a 3D cadastre

Based on the conclusions of part I and part II, three concepts with several alternatives were distinguished (the UML class diagrams were also drawn in chapter 10):

- Full 3D cadastre:
  - Alternative 1: combination of infinite parcel columns and volume parcels
  - Alternative 2: only parcels are recognised that are bounded in three dimensions (volume parcels)
- Hybrid cadastre:

- Alternative 1: registration of 2D parcels in all cases of real property registration and additional registration of 3D legal space in the case of 3D property units
- Alternative 2: registration of 2D parcels in all cases of real property registration and additional registration of physical objects
- 3D tags linked to parcels in current cadastral registration, additional information is available on analogue or scanned documents and drawings.

### 13.3.2 The optimal solution for a 3D cadastre

Based on both technical and cadastral criteria the most feasible solutions for the Dutch situation was selected.

The full 3D cadastre showed best potentials, since the 2D parcel as (only) basic concept of cadastral registration is abandoned. Consequently the 3D cadastral issue is solved at a fundamental level. In a full 3D cadastre it is possible to transfer a volume parcel, without relating the property rights for this space to the surface parcel. In this thesis we presented two variants of a full 3D cadastre: one with both volume parcels and infinite 3D columns (which are defined by the parcel boundaries on the surface from which volume parcels may be subtracted) and one with only bounded volume parcels. The advantage of the first alternative is that this variant still has a strong link to the current 2D registration and conversion of the current cadastral registration into this variant is more feasible. The first alternative also has the advantage of being able to represent infinite (open) 3D parcel columns, which still suffice in 2D property situations (where only one person is entitled to a parcel). It was therefore decided to select and refine this model.

The first alternative of a full 3D cadastre can only become practise if the juridical and cadastral frameworks can be extended to establish a volume parcel that is no longer related to the surface configuration. However, as was seen in part I, it is dependent on the type of cadastral registration and the legal system of a specific country if volume parcels will be easily permitted. Cadastral registration in the Netherlands seems to be still very land oriented (as in Denmark and Israel, but also in British Columbia where air-space parcels have to be totally located within one parcel), and the step towards a full 3D cadastre might be too ambitious for the medium-term future. Therefore concurrently with the full 3D cadastre, the possibilities and constraints of the hybrid cadastre were studied.

In the hybrid cadastre 3D situations (factual situations) are registered apart from 2D parcels (juridical situations) in one integrated environment. This solution fits within the Dutch juridical framework and with some extent within the cadastral and technical framework (changes needed in cadastral and technical framework can be achieved within a few years in standard products or self-developed software). In the hybrid cadastre property rights to real estate are still always registered on parcels on the surface. This is the basic difference from the full 3D cadastre concept.

Two possible alternatives were introduced to effectuate the hybrid solution: registration of 3D right-volumes and registration of 3D physical objects. In the registration of 3D right-volumes the limited rights registered on parcels form the starting point:

what rights are established on a parcel and what is the space where the rights are valid. A 3D representation of this space is registered in the cadastral registration. In contrast, in a 3D physical object registration the 3D physical object is the starting point of registration, independent of the rights that have been established. Preferably 3D information on physical objects is maintained by organisations responsible for the objects and accessible in the cadastral database via the Geo-Information Infrastructure.

The solution of '3D tags in the current cadastral registration' is a solution that works, as current practise proves, however it has some basic limitations. The solution cannot provide one 3D overview of the cadastral map integrated with 3D property situations: 3D situations can only be examined per parcel, i.e. isolated from each other. This solution does therefore not give a base for efficient and sustainable registration in the future.

## 13.4 Realisation of a 3D cadastre

The concepts of the first alternative of the full 3D cadastre and the two alternatives for the hybrid cadastre were translated into logical models and prototypes in part IV. The prototypes were implemented within the juridical, cadastral and technical framework described in part I and part II. The aim of the prototypes was to evaluate the conceptual models. The concepts of the hybrid cadastre were applied to the Dutch case studies introduced in chapter 3, since the Netherlands' Kadaster still holds strongly to the 2D parcel concept as in the hybrid cadastre. The concept of the full 3D cadastre was evaluated by applying this concept to a case study in Brisbane, Queensland that was introduced in chapter 4, since the juridical framework in Queensland provides the establishment of 3D property units independently from the surface configuration.

Conclusions based on the experiments with the full 3D cadastre prototype are listed in section 13.4.1, while the conclusions for the hybrid cadastre are described in section 13.4.2.

### 13.4.1 Full 3D cadastre

In the full 3D cadastre prototype environment (based on a 3D polyhedron extended version of the Oracle spatial DBMS and ESRI and Bentley GIS/CAD software), the 3D property survey plans were converted into a spatial representation in the DBMS and the surface parcels were successfully merged with a terrain elevation model.

#### **Conclusion on full 3D cadastre**

The full 3D cadastre offers many improvements compared to traditional cadastral registrations:

- The real situation is no longer projected on the surface, i.e. volume parcels are not dominated by the parcel pattern on the surface.
- Persons can straightforwardly be entitled to space instead of establishing property rights on intersecting parcels.



- The space is precisely described in a 3D survey document, which offers a uniform way of defining 3D property units.

In addition, implementing the full 3D cadastre offers also improvements for cadastral registration in countries and states that already establish 3D property units as volume parcels in the juridical framework:

- The information from the 3D survey document can be used to insert the geometrical and topological description of volume parcels in the DBMS.
- The volume parcels can be viewed interactively.
- The geometry of volume parcels can be checked, e.g. whether faces are planar or not.
- The 3D situation can be (spatially) queried in the DBMS (e.g. do volume parcels intersect?).
- The volume parcels can be visualised in an integrated view with a 2.5D representation of the parcels that are defined by parcel boundaries on the surface.
- The volume parcel and the 2.5D surface parcels can be queried in the DBMS (e.g. is a volume parcel located above or below the surface, or does it intersect the surface?).

The prototype environment of the full 3D cadastre offers the possibility to query, analyse and visualise the true 3D situation of the properties. However, while the legal, organisational and technical aspects of a 3D cadastre have been solved, some non-trivial aspects (in the conversion and use of a 3D cadastre) require further attention as was showed by the case study (e.g. how to model volume parcels with complex geometries).

### 13.4.2 Hybrid cadastre

When a juridical framework cannot yet deal with the establishment of property rights to volumes independent from the surface, the 3D cadastre can be implemented within a hybrid environment introducing either 3D right-volumes or a 3D physical object registration.

#### 3D right-volumes

From the prototype implementations it can be concluded that the introduction of 3D right-volumes means a significant improvement of current cadastral registration in 3D situations. The inclusion of 3D right-volumes in the cadastral geographical data set provides an overview of the distribution of 3D property units. The registration warns the user of the cadastral registration that something is located under or above the surface. It also gives information on what is located under or above the surface (relationship with whole real estate object is maintained). For precise information the deed in the land registration can be consulted. A 3D survey of the situation can be made and used to describe the situation in the deeds and to determine the upper and lower limits of 3D right-volumes.

From a technical point of view, the geometry of 3D right-volumes is simple and can therefore be maintained in the DBMS within current techniques.

Basic disadvantages of 3D right-volumes are:

- Since parcels are still the basis for registration, gaps can occur when no rights have been established that require a cadastral recording, e.g. when the holder of the construction is the same as the owner of the intersecting parcel. In these cases the location of the construction is still not known in the cadastral registration.
- If rights are established on just a part of a parcel, new parcel boundaries need to be created. This leads to fragmentation of both parcels and 3D right-volumes.
- When space where the right applies to is not precisely restricted in height or depth, registration of 3D right-volumes does not give satisfying insight, as was seen in the Rijswijk case. This could be solved by a rule applying to 3D surveys that will allow open polyhedrons (either not defined in height or in depth).
- Horizontal boundaries restrict the spatial description of 3D right-volumes. The concept of a 3D right-volume could be improved when other than just horizontal boundaries could be defined.

### **Registration of 3D physical objects**

The registration of 3D physical objects comprises the registration of physical objects as they occur in the real world. From the experiments with the case studies it can be concluded that such a registration offers several improvements. The 3D description of the physical objects (extent of the object) can be used for reference purposes (to improve the reflection of the real situation) and to support cadastral tasks. When a 3D physical object is registered parcels do not need to be divided into parcels matching with the 2D projection of the physical object since the exact location of the physical object is known in the cadastral database. Only one object needs to be registered by which the registration for all intersecting parcels can be guaranteed. All parcels intersecting with the physical object can be found by a spatial query (by an overlay with the projection of the 3D object).

From a technical point of view the geometry that has to be maintained for physical objects can become complex. It is therefore not easy and straightforward to insert and maintain the spatial information on 3D physical objects within current techniques.

### **Conclusion on hybrid cadastre**

Since both solutions of the hybrid cadastre are implemented within the current Dutch juridical and cadastral framework, rights to hold 3D property units are still registered on the intersecting parcels. Querying the legal status of 3D property units still needs to be done by querying the legal status of the intersecting parcels. However the maintenance of the 3D situation can assist considerably in understanding the real situation.

Cadastral registration will benefit for a number of reasons from a hybrid registration:

- The solutions give insight into the real situation. It is now clear from the cadastral registration that persons are entitled to space above or below the surface.
- Both solutions are implemented within the cadastral registration as part of the cadastral geographical data set and can therefore be queried with parcel surfaces in one integrated view.

- The proposed solutions show notaries how the inclusion of spatial information in deeds can be used to visualise the 3D component of rights in the cadastral registration. The solution can make notaries aware of the improvements of 3D registration and may motivate them to include well-defined 3D information in the deeds.
- Registrations and databases outside the cadastral domain can benefit from the information on 3D situations that is available in the cadastral registration and versa via the Geo-Information Infrastructure (monument registration, building registration, taxes for immovable goods, management of soil pollution areas, management of cables and pipes, management of the subsurface).

In chapter 3, the case studies were divided into building complexes and infrastructure objects. A physical object relating to a property unit within a building complex coincides with the legal space of the property unit. The main objective of cadastral registration in the case of building complexes is to give insight into property boundaries in all dimensions rather than to reflect the built constructions in the cadastral registration for reference purposes. On the other hand, the main objectives of a registration of 3D physical objects are firstly to be able to locate infrastructure objects to support cadastral tasks and secondly to register the person who holds an infrastructure object. Therefore, the registration of 3D physical objects will specifically be suitable for infrastructure objects. For registering property units in building complexes, 3D right-volumes are more appropriate, because the spatial extent of property units can be easily and clearly defined with 3D right-volumes which refer to the legal space to which a person is entitled.

The two concepts of the hybrid cadastre (3D right-volumes and 3D physical object registration) have a different line of approach and therefore meet other needs of 3D cadastral registration. The 3D right-volume is a considerable improvement of insight into stratified property as part of the cadastral geographical data set, while the 3D physical object registration provides information on constructions which is available in the cadastral geographical data set to improve the reflection of the real situation. The concepts could be combined to take advantage of both solutions.

## 13.5 Future directions for a Dutch 3D cadastre

In the Netherlands, where the property rights to real estate are still very much land (surface) oriented within the existing juridical doctrine and cadastral framework, the hybrid cadastre seems to be the best solution for the medium-term future. The proposed alternatives meet the requirements of 3D cadastral registration. Insight into the legal status of 3D property is improved, because the 3D extent of rights is established in the case of right-volumes. In the case of a 3D physical object registration the construction itself is available in the cadastral registration by which the real situation is much better reflected. However, one basic principle is not addressed. Since the legal status of constructions and 3D property units is still registered by means of land parcels, querying the legal status in 3D still means collecting information on the legal status of the intersecting parcels.

As was seen in chapter 1, the FIG Bathurst Declaration [55] concluded already that “most land administration systems today are not adequate to cope with the increasingly complex range of rights, restrictions and responsibilities in relation to land”. As in the Netherlands, many other existing cadastres are still based on the paradigm of a land parcel that has its origin centuries ago. This paradigm needs to be reconsidered and adjusted to today’s world. Although parcels are traditionally represented in 2D, someone with a right to a parcel always has been entitled to a space in 3D. This led to no disputes as long as only one person was entitled to a land parcel since the traditional cadastre was capable of reflecting such property situations. However, in recent times stratified property is common practise, and in many countries multifunctional use of space is official planning policy. Also the way humans relate to land has changed drastically (value of private property has increased considerably). Today’s cadastral registration should therefore reflect the true principle of property rights that entitle persons to volumes and not to just areas.

The ultimate ambition for 3D cadastral registration should be a full 3D cadastre in which it is possible to entitle persons both to unconstrained parcel columns that are defined by boundaries on the surface and to bounded amounts of space (volume parcels).

The optimal solution for such a full 3D cadastre starts with the regulations for 3D surveys in case of stratified property (volume parcels). The volume parcel is then inserted in the land registration and known as an individual property that can be transferred independently from other properties.

The information from the 3D survey plans (in which the height is defined in absolute z-values within the national reference system) can be used to register the volume parcels in the cadastral registration and can be used to insert the 3D geometrical and topological characteristics of the volume parcels in the cadastral database. To be able to query the volume parcels and the parcels that are defined by boundaries on the surface in one environment the surface parcels need to be represented by 2.5D surfaces. After this whole procedure is clearly defined, the process from 3D survey to insertion in the cadastral database can be streamlined.

The experiments of the case study in Queensland using the prototype of a full 3D cadastre showed that the legal, organisational and technical aspects in a full 3D cadastre are solved and that the proposed alternative of a full 3D cadastre is realisable. In a technical sense the basic conditions for a full 3D cadastre are met (although these technologies still need further development). However, the actual implementation of a full 3D cadastre in the Netherlands (as in other countries) may meet complications. It requires a change in the way of thinking about the right of ownership and other property rights since in the full 3D cadastre the basic paradigm of land oriented real estate has to be abandoned. However, since a full 3D cadastre offers solutions for 3D cadastral registration at a fundamental level and since the 3D principle of property is appropriately reflected in the cadastral registration, steps towards a full 3D cadastre should be further studied and be taken in the future.

## 13.6 Further research

Future research concerning the different aspects of 3D cadastral registration should focus on a number of areas.

### 13.6.1 Institutional aspects of 3D cadastral registration

In order to accomplish better methods to register 3D property units, the juridical framework in the Netherlands should be further examined. 3D cadastral registration in case of a full 3D cadastre is only possible when the juridical framework provides the possibility to establish volume parcels.

Further research should therefore focus on the following questions. How flexible is the definition of ownership of land from both a juridical and a cadastral point of view? Is it possible to establish volume parcels as in Queensland, British Columbia, Norway and Sweden without changing the Civil Code? Are the juridical complexities to establish volume parcels higher than the benefits? How easy is it to change cadastral registration to register real estate objects other than parcels and apartment units? Also further research is needed on what 3D information is needed in deeds and survey plans and how this information should be collected, structured and offered to make a 3D cadastral registration possible.

### 13.6.2 Geo-Information Infrastructure

In today's society information is of growing importance and especially information exchange via the Internet is vital. The Geo-Information Infrastructure facilitates the exchange of geo-information across the Internet. A distributed set-up of registrations within a GII provides the possibility to link information maintained in different databases. In this way the geometry of objects such as infrastructure, soil pollution area and monuments, can remain and be maintained at their original source (in databases of organisations who are responsible for these objects), while this information can be used to improve cadastral registration in case of 3D situations. Also other persons and organisations can benefit from a 3D cadastral registration within a GII, since information from the cadastre is much easier accessible. Therefore the establishment of a Geo-Information Infrastructure needs further research concerning both technical and organisational aspects. The research on GII is also pushed by a growing need to integrate data sets from different domains and different countries. This requires specific research, including the development of formal semantics.

### 13.6.3 3D in the new generation GIS architecture

In the area of 3D in the new generation GIS architecture, future research should include the following topics.

#### **3D modelling in DBMSs**

To improve 3D modelling in DBMS, the following issues need special attention:

- 3D (volumetric) data types are future work for standard DBMSs. The polyhedron primitive as it is implemented and described in this research showed possibilities for maintaining 3D geo-objects in a DBMS and is a first step towards 3D support in DBMSs. Future research should focus on implementing a more complex geometrical primitive in the DBMS, e.g. using curved surfaces.
- At present, 3D implementations are focused on boundary representation. However Constructive Solid Geometry (CSG) may appear appropriate for designed large-scale man-made objects (traffic signs, buildings) and voxel representation (3D raster) for continuous phenomena. Therefore future 3D GIS may ask for the support of CSG and voxels (or other 3D tessellations) in DBMS.
- Topological structure in 3D is not supported in DBMS within current techniques although topological structure can be stored in relational tables. Since the DBMS does not support the 3D topological structure, future research should focus on full support for 3D topological structure, i.e. performing consistency checks and resolving topological errors inside the DBMS. An OGC Implementation Specification for 2D topological structure also still needs to be finalised. Recently 2D topological structure is available in commercial products. Research is needed in order to assess these implementations.
- Current DBMSs only support spatial functions in 2D. Future research should focus on 3D spatial analyses (e.g. overlay, buffer, route planning, visibility) and 3D querying.

### **Accessing 3D objects organised in a DBMS**

Concerning the Web based solution to access 3D spatial objects which are organised in a DBMS, future work should focus on a number of research issues. Although first experiences with the prototypes look promising with respect to performance, serious tests on larger data sets need to be set up. Fast rendering of 3D objects is of course critical when displaying data via the Internet. Other issues that need attention when disseminating 3D geo-information via the Internet are: how to access data stored in separate DBMSs and how to address 3D cartographic aspects (perspective, stereo, movement, transparency, sticks that indicate the distance between a subsurface construction and the surface level etc.)? This requires that not only spatial and non-spatial information for spatial objects are maintained in the DBMS but also characteristics such as physical properties of objects (texture, material, colour), behaviour (e.g. on-click-open) and different Levels Of Detail representations. To join the interoperability standards of the OpenGIS Consortium the OGC Web Services (and especially the Web Feature Service) should be studied to see how these services can be used to disseminate 3D geo-information across the Internet.

### **3D data collection**

Future research is needed to make the process of 3D object reconstruction (semi) automatic. In general the process of 3D object construction is non-trivial (even using advanced sensors and reconstruction software) and still needs to be done partly manually, which is therefore relatively time consuming. In addition underground constructions such as tunnels and pipelines cannot be modelled using aerial laserscan and photogrammetry techniques. Therefore it is needed to have a look at the designed CAD models. To improve 3D object reconstruction for geo-purposes, future research should focus in detail on the interoperability problem between GIS and CAD

in order to be able to use CAD designs in 3D GIS and to use 3D edit functionality and advanced visualisation techniques available in CAD in 3D GIS. A small number of such problems has already been investigated in the case studies that were carried out as part of this thesis, i.e. lack of object definitions in the CAD models, different scale representations, transformation of the local (CAD) coordinates into a reference system for both the horizontal and vertical coordinates, parametric shapes that cannot easily be converted into simple geometries, different levels of detail that requires generalisation. The use of detailed CAD models in GIS requires 3D generalisation algorithms. Therefore 3D generalisation is a fundamental issue that needs special attention when bridging the gap between CAD and GIS.

In general the basic problems of linking GIS and CAD need better understanding in order to close the gap between GIS and CAD [143]. For this at least two important developments are needed. The first one is a semantic analysis of the concepts of these ‘different’ worlds. A two-way translation is needed between these concepts. Second, both GIS and CAD should base their data management on the same technology, for example spatial DBMSs compliant with OpenGIS (ISO) standards. Therefore first the CAD standards and GIS standards need to be harmonised.

### **Generating effective integrated model of point heights and parcels**

The integrated height and object model, represented in a TIN could be improved. Future work with respect to the integrated model should include the following topics:

- The TIN computation should be performed inside the DBMS to avoid time-consuming conversions that may lead to a decrease in the quality of the data. The ideal case would be just storing the point heights and the parcel boundaries in one or preferably in distributed DBMS(s) and to generate the TIN (available in a view) of the area of interest on user’s request in the DBMS, without storing the TIN explicitly. This is more efficient because no data transfer (and conversion) is needed from DBMS to TIN software and back. Future research should therefore focus on supporting TIN data structure, TIN creation and TIN data reduction methods within the DBMS.
- As indicated in section 9.3, the current TIN computation takes place in the 2D plane. It may be better to compute the integrated height and object model in true 3D space, based on tetrahedra (and then finding the proper parcel surface within this tetrahedron network) (see also [220]).
- In the implemented data reduction method the reduction is only based on reducing the number of point heights. In the future, the generalisation of the integrated model should also take into account the 2D objects, especially the boundary line generalisation and the object aggregation. This will lead to an integrated data reduction procedure of 2D objects and point heights, taken the constraints defined by the 2D objects into account. In the data reduction process, the planar partition of the 2D objects should always be part of the TIN structure, by which it is possible to extract height surfaces for individual 2D objects.
- Maintain the result of the generalisation in a multi-scale data structure, as the costs of the computations are significant. This requires further research on multi representations at different scales in DBMSs.

## 13.7 Main results of this thesis

The main objective of this thesis focused on how to record 3D situations in a cadastral registration in order to improve insight into 3D property situations. Based on the findings of the background study, the study on technological possibilities and the experiments with the case studies, it can be concluded that a full 3D cadastre that both registers surface parcels and volume parcels offers best potentials and is realisable. Cases in Queensland, British Columbia, Norway and Sweden showed already that it is possible to establish volume parcels within the juridical frameworks. This thesis showed that it is possible to register volume parcels together with 2.5D surfaces of parcels within a cadastral and technical framework. It can therefore be expected that in the near future more countries and states (including the Netherlands) will implement (further) steps towards the full 3D cadastre model as described in this thesis.

In a technical sense this research contributed to 3D developments within the new generation GIS architecture in general, since the prototypes showed that it is possible to maintain 3D objects using 3D geometrical primitives in a DBMS, to perform spatial functions in 3D within the DBMS on the 3D objects, to access the geo-DBMS containing 2D and 3D geo-objects using GIS/CAD front-ends and Web based technology and, finally, to combine 2D geo-objects and 3D geo-objects in one 3D environment by generating an effective structure of a 2.5D surface that incorporates the planar partition of 2D geo-objects.

This thesis showed and implemented major preconditions to establish a full 3D cadastre within a juridical, cadastral and technical framework. However, a lot of technical limitations still need to be tackled to have commercially available tools to support a full 3D cadastre that can operate as part of a GII and also still many cadastral and juridical issues need to be addressed to accomplish a full 3D cadastre, at least in the Netherlands.



# Bibliography

- [1] H.J.G.L. Aalders and M. Reuvers. 2004, het begin van een nieuw normen tijdperk (in Dutch). In *Proceedings GIN 2004, Geoinformatiedag Nederland 2004*, Ede, June 2004.
- [2] A. Aguilera. *Orthogonal polyhedra: study and application*. PhD thesis, Universitat Politècnica de Catalunya, Barcelona, Spain, 1998.
- [3] T.M. Aldridge and A. van Velten. Apartment Ownership in the European Union. *Notarius International*, pages 17–30, 1997.
- [4] C. Arens. Maintaining reality: modelling 3D spatial objects in a Geo-DBMS using a 3D primitive. Technical Report MSc thesis, Delft University of Technology, Delft, the Netherlands, 2003.
- [5] C. Arens, J.E. Stoter, and P.J.M. van Oosterom. Modelling 3D spatial objects in a GeoDBMS using a 3D primitive. In *Proceedings AGILE 2003*, Lyon, France, April 2003.
- [6] S. Aronoff. *Geographic Information Systems: a management perspective*. WDL publications, Ottawa, Canada, 1989.
- [7] B.G. Baumgart. Winged-Edge Polyhedron Representation for Computer Vision. In *Proceedings of National Computer Conference*, pages 589–596, Stanford, California, USA, May 1975.
- [8] L.A. Belfore. An architecture supporting live updates and dynamic content in VRML based virtual worlds. In *Proceedings of Symposium on Military, Government and Aerospace Simulation 2002 (MGA 2002)*, pages 138–143, San Diego, California, April 2002.
- [9] M. Benhamu and Y. Doytsher. A Multilayer 3D Cadastre: Problems and Solutions. In *Proceedings FIG, ACSM/ASPRS*, Washington D.C. USA, April 2002.
- [10] Bentley. Bentley MicroStation GeoGraphics Spatial edition, 2004. [www.bentley.com/products](http://www.bentley.com/products).
- [11] E. Bignone, O. Henricsson, P. Fua, and M. Stricker. Automatic extraction of generic house roofs from high resolution aerial imagery. In *Proceedings of European Conference on Computer Vision - ECCV'96*, volume 1, pages 85–96, Cambridge, UK, April 1996.

- [12] T. Blaschke and D. Tiede. Bridging GIS landscape analysis, modelling and 3D simulation. Is this already 4D? In *Proceedings of CORP 2003 Geo Multimedia*, Vienna University of Technology, Austria, February 2003.
- [13] L. Bodum. 3D Mapping for Urban and Regional Planning. In *Proceedings of URISA Annual Conference 2002*, pages 472–479, Chigaco, USA, 2002.
- [14] P. Bottelier, R. Haagmans, and N. Kinneging. Fast Reduction of High Density Multibeam Echosounder Data for Near Real-Time Applications. *The Hydrographic Journal*, (98):23–28, 2000.
- [15] P.W. Bresters. 3D Visualisations with the Height Model of the Netherlands (AHN). In *Proceedings of EuroSDR Commission V Workshop on Visualisation and Rendering*, Enschede, the Netherlands, January 2003.
- [16] British Columbian Government. *Land Title Act*. British Columbia, Canada, 1996.
- [17] British Columbian Government. *Land Title Regulations*. British Columbia, Canada, 1996.
- [18] R. Brügelmann. Automatic breakline detection from airborne laser range data. *International Archives of Photogrammetry and Remote Sensing*, 33(B3/1):103–110, 2000.
- [19] B. Cambray. Three-dimensional modelling in a geographical database. In *Proceedings Auto-Carto'11: 11th International Conference on Computer Assisted Cartography*, pages 338–347, Minneapolis, USA, 1993.
- [20] E. Carlson. Three-dimensional conceptual modelling of subsurface structures. In *Proceedings of ASPRS/ACSM Annual Convention*, volume 4, pages 188–200, Baltimore, USA, 1987.
- [21] CEN. Comité Européen de Normalisation CEN/TC 287 - Geopgraphic Information, 2004. [www.cenorm.be](http://www.cenorm.be).
- [22] CGAL Consortium. CGAL Basic Library, 2004. [www.cgal.org](http://www.cgal.org).
- [23] P.P. Chen. The Entity Relationship Model: Toward a Unified View of Data. *ACM Transactions on Database Systems*, 1(1):9–36, 1976.
- [24] E. Clementini, P. Di Fellice, and P. van Oosterom. A Small Set of Formal Topological Relationships Suitable for End-User Interaction. In *Proceedings of the Third International Symposium on Advances in Spatial Databases, SSD'93*, volume 692 of *Lecture Notes in Computer Science*, pages 277–295, Singapore, June 23-25 1993. Springer-Verlag.
- [25] V. Clerc, R. van Lammeren, A. Ligtenberg, H. Kramer, and A. Ligtenberg. Virtual Reality in the landscape design process. In *Proceedings International conference on landscape planning*, Portoroz, Slovenia, November 2002.

- 
- [26] S. Cockcroft. Towards the automatic enforcement of integrity rules in spatial database systems. In *Proceedings of 8th Colloquium of the Spatial Information Research Centre*, pages 33–42, University of Otago, Dunedin, New Zealand, July 1996.
- [27] E.F. Codd. A relational model of data for large shared banks. *Communications ACM*, 13(6):377–387, June 1970.
- [28] D. Comer. The ubiquitous B-tree. *ACM Computing Surveys*, 11(2):121–137, 1979.
- [29] V. Coors. Resource-adaptive 3D maps for LBS. In *Proceedings UDMS 2002*, Prague, Czech Republic, October 2002.
- [30] V. Coors. 3D GIS in networking environments. *Computers, Environments and Urban Systems (CEUS)*, 27(4):345–357, 2003.
- [31] V. Coors and V. Jung. Using VRML as an interface to the 3D Data Warehouse. In *Proceedings of the third symposium on VRML*, pages 121–129, New York, USA, 1998.
- [32] D.J. Cowen. GIS versus CAD versus DBMS: What are the differences? *Photogrammetric Engineering and Remote Sensing*, 54(11):1551–1555, November 1988.
- [33] D.H. Douglas and T.K. Peucker. Algorithms for the reduction of points required to represent a digitized line or its caricature. *Canadian Cartographer*, 10(2):112–122, 1973.
- [34] S.E. Dowson and V.L.O. Sheppard. *Land registration, page 47*. Colonial Research Publications No 13. Her Majesty’s Stationary Office, London, UK, second edition, 1952.
- [35] S. Doyle, M. Dodge, and A. Smith. The potential of web-based mapping and virtual reality technologies for modelling urban environments. *Computers, Environments and Urban Systems (CEUS)*, 22(2):137–155, 1998.
- [36] Dutch Government. Mijnwet 1810. Loi concernant les Mines, les Minières et les Carrières du 21 avril 1810 (Bulletin des Lois 1810, 25), 1810.
- [37] Dutch Government. Belemmeringenwet Privaatrecht. Wet van 13 mei 1927, tot opheffing van privaatrechtelijke belemmeringen, Staatsblad 2001, 548 (in Dutch), 1927.
- [38] Dutch Government. Luchtvaartwet. Wet van 15 januari 1958, houdende nieuwe regelingen omtrent de luchtvaart, Staatsblad 1995, 554 (in Dutch), 1958.
- [39] Dutch Government. Monumentenwet. Wet van 23 december 1988, tot vervanging van de Monumentenwet, Staatsblad 1997, 291 (in Dutch), 1988.
- [40] Dutch Government. Kadasterbesluit. Besluit van 6 November 1991, houdende vaststelling van het Kadasterbesluit, Staatsblad 1991, 570 (in Dutch), 1991.

- [41] Dutch Government. *Dutch Civil Code (Burgerlijk Wetboek), Boek 5: Zakelijke rechten (in Dutch)*. The Hague, 1992.
- [42] Dutch Government. Wet Bodembescherming. Staatsblad 1994, 331 (in Dutch), 1994.
- [43] Dutch Government. Kadasterwet. Staatsblad 1995, 71 (in Dutch), 1995.
- [44] Dutch Government. Telecommunicatiewet. Wet van 19 oktober 1998, houdende regels inzake de telecommunicatie (Telecommunicatiewet), Staatsblad 1998, 318 (in Dutch), 1998.
- [45] Dutch Government. Mijnbouwwet. Wet van 31 oktober 2002, houdende regels met betrekking tot het onderzoek naar en het winnen van delfstoffen en met betrekking tot met de mijnbouw verwante activiteiten, Staatsblad 2002, 617 (in Dutch), 2002.
- [46] Dutch Government. Uitspraak van de Hoge Raad m.b.t. de status van kabels voor telecommunicatie. Hoge Raad 6 juni 2003, nr. 36.076, Jurisprudentie Onderneming & Recht 2003/222 (in Dutch), June 2003.
- [47] M.J. Egenhofer. Spatial SQL: A Query and Presentation Language. *IEEE Transactions on Knowledge and Data Engineering*, 6(1):86–95, 1994.
- [48] M.J. Egenhofer, E. Clementini, and P. Di Felice. Evaluating inconsistencies among multiple representations. In *Proceedings of 6th International Symposium on Spatial Data Handling*, pages 901–920, Edinburgh, Scotland, 1994.
- [49] M.J. Egenhofer and J. Herring. Categorizing binary topological relationships between regions, lines and points in geographic databases. Technical report, Department of Surveying Engineering, University of Maine, Orono, USA, 1991.
- [50] ERDAS, 2004. [www.erdas.com](http://www.erdas.com).
- [51] ESRI. ESRI, ArcGIS, 2004. [www.esri.com](http://www.esri.com).
- [52] C. Faloutsos and S. Roseman. Fractals for secondary key retrieval. In *Proceedings of the eight ACM Symposium on Principles of Database Systems*, pages 247–252, Philadelphia, Pennsylvania, USA, March 1989.
- [53] FIG. The FIG Statement on the Cadastre. Technical Report Publication No. 11, Federation International des Géomètres, Commission 7, 1995.
- [54] FIG. Cadastre 2014, a vision for a future cadastral system. Technical report, Federation International des Géomètres, Commission 7, J. Kaufmann and D. Steudler, 1998.
- [55] FIG. The Bathurst Declaration on Land Administration for Sustainable Development. Technical Report Publication No. 21, Federation International des Géomètres, October 1999.

- 
- [56] S. Flick. An object-oriented framework for the realisation of 3D Geographic Information Systems. In *Proceedings of the second joint European Conference and Exhibiton on Geographical Information*, pages 187–196, Barcelona, Spain, 1996.
- [57] J. Forrai and G. Kirschner. Transition from two-dimensional legal and cadastral reality to a three-dimensional case. In *Proceedings of International Workshop on 3D Cadastres, FIG*, pages 9–24, Delft, the Netherlands, 28-30 November 2001.
- [58] J. Forrai and G. Kirschner. An interdisciplinary 3D Cadastre Development Project in Practice. In *Proceedings FIG Working Week 2003*, Paris, France, April 2003.
- [59] W. Förstner. A framework for low level feature extraction. In *Proceedings of Computer Vision - ECCV94*, volume 2, pages 383–394, Stockholm, Sweden, 1994.
- [60] C. Fowler and E. Treml. Building a marine cadastral information system for the United States - a case study. *Computers, Environments and Urban Systems (CEUS)*, 25(4-5):493–507, 2001.
- [61] J. Gerremo and J. Hannson. Ownership and real property in British Columbia: a legal study. Technical Report MSc thesis nr. 48, Royal Institute of Technology, Department of Real Estate and Construction Management, Division of Real Estate Planning and Land Law, Stockholm, Sweden, 1998.
- [62] B. Gorte. Segmentation of TIN-structured surface models. In *Proceedings of Joint Conference on Geo-spatial Theory, Processing and Applications*, Ottawa, Canada, July 2002.
- [63] A. Grinstein. Different aspects of a 3D cadastre in the new town Modi'in, Israel. In *Proceedings of International Workshop on 3D Cadastres, FIG*, pages 25–34, Delft, the Netherlands, 28-30 November 2001.
- [64] R. Grinstein. A real-world experiment in 3D cadastre: mapping of underground parking for registration rights. *GIM International*, pages 65–67, September 2003.
- [65] R. Groot and J. McLaughlin, editors. *Geospatial data infrastructure - Concepts, cases, and good practice*. Oxford University Press, Oxford, 2000.
- [66] M. Gruber, M. Pasko, and F. Leberl. Geometric versus texture detail in 3D models of real world buildings. In *Proceedings of Ascona Workshop 95 on Automatic Extraction of Man-Made objects from Aerial and Space Images*, pages 189–198, Basel, Switzerland, 1995. Birkhäuser Verlag.
- [67] A. Grün and X. Wang. CC-modeller: a topology generator for 3D city models. *ISPRS Journal*, 53(5):286–295, 1998.
- [68] A. Guttman. R-trees: a dynamic index structure for spatial searching. In *Proceedings ACM International Conference on Management of Data*, pages 188–196, Boston, USA, June 1984.

- [69] N. Haala. Combining multiple data sources for urban data acquisition. In *Proceedings of Photogrammetric Week 1999*, pages 329–339, Stuttgart, Germany, September 1999.
- [70] P. de Haan. Eigendom, beheer en registratie van ondergrondse infrastructuur (in Dutch). *Nederlands Juristenblad*, 79:564–570, Maart 2004.
- [71] P. de Haan. Eigendomsverhoudingen bij privatisering van energiebedrijven (in Dutch). *Bouwrecht*, 41(4):283–292, April 2004.
- [72] R.M. van Heerd et al. Productspecificatie AHN 2000. Technical Report MDTGM 2000.13, Rijkswaterstaat, Meetkundige Dienst, 2000.
- [73] J. Henssen. Basic Principles of the Main Cadastral Systems in the World. In *Proceedings of One day Seminar held during the Annual Meeting of Commission 7, Cadastre and Rural Land Management, FIG*, Delft, the Netherlands, May 1995.
- [74] I. Heywood, S. Cornelius, and S. Carver. *An introduction to Geographical Information Systems*. Prentice Hall, 1998.
- [75] F. Hobbs and C. Chan. AutoCAD as a cartographic training tool: A case study. *Computer Aided Design*, 22(3):151–159, 1990.
- [76] M. Hoefsloot. 3D Geo-Informatie uit bestaande CAD modellen (in Dutch). Technical Report MSc case study report, TU Delft, Section GIS technology, 2003.
- [77] E. Hoel, S. Menon, and S. Morehouse. Building a robust relational implementation of topology. In *Proceedings of 8th International Symposium on Spatial and Temporal Databases*, pages 508–524, Santorini, Greece, July 2003.
- [78] A.D. Hofmann, H-G. Maas, and A. Streilein. Knowledge-Based Building Detection Based On Laser Scanner Data And Topographic Map Information. In *Proceedings of Symposium on Photogrammetric Computer Vision, ISPRS Commission III*, pages 169–174, Graz, Austria, September 2002.
- [79] R. Hoinkes and E. Lange. 3D for Free - Toolkit Expands Visual Dimensions in GIS. *GIS World*, 8(7):54–56, 1995.
- [80] T. Höllerer, S. Feiner, T. Terauchi, G. Rashid, and D. Hallaway. Exploring MARS: Developing Indoor and Outdoor User Interfaces to a Mobile Augmented Reality System. *Computers and Graphics*, 23(6):779–785, 1999.
- [81] M. Huml. Legal view, conditions and experiences in the Czech Republic. In *Proceedings International Workshop on 3D Cadastres*, Delft, the Netherlands, November 2001.
- [82] IBM. IBM DB2 Spatial Extender User’s Guide and Reference. Special web release edition. Technical report, IBM, 2000.
- [83] Informix. Informix Spatial DataBlade Module User’s Guide. Technical Report Part no. 000-8441, Informix, 2000.

- 
- [84] Ingres. CA-OpenIngres, INGRES/Object Management Extension User's Guide, Release 6.5. Technical report, 1994.
- [85] Intergraph. Geomedia, 2004. [www.intergraph.com](http://www.intergraph.com).
- [86] ISO. ISO/TC 211, Geographic information/Geomatics, Revised report of the secretariat to the 17th plenary meeting of ISO/TC 211 in Berlin, Germany, 2003-10-30/31. Technical report, 2003.
- [87] ISO. ISO/TC 211, ISO International standard 19107:2003, Geographic information - Spatial schema. Technical report, 2003.
- [88] K. Jacobsen and P. Lohmann. Segmented filtering of laser scanner DSMs. In *Proceedings of ISPRS working group III/3 workshop 3D reconstruction from airborne laserscanning and InSAR data*, pages 87–93, Dresden, Germany, October 2003.
- [89] J. de Jong. *Erfpacht en opstal (in Dutch)*. Kluwer, Deventer, 1995.
- [90] J. de Jong. Juridische aspecten van ondergronds bouwen (in Dutch). *Bouwrecht*, 35(6):453–459, 1998.
- [91] B. Julstad and A. Ericsson. Property formation and three-dimensional property units in Sweden. In *Proceedings of International Workshop on 3D Cadastres, FIG*, pages 173–190, Delft, the Netherlands, 28-30 November 2001.
- [92] A.P. Kap and J.A. Zevenbergen. Valkuilen en kansen bij de opzet van landelijke registraties: een (inter)nationale vergelijking (in Dutch). Technical report, Department of Geodesy, Delft University of Technology, 2000.
- [93] H. de Kluijver and J.E. Stoter. Noise mapping and GIS: optimising quality and efficiency of noise effect studies. *Computers, Environment and Urban Systems (CEUS)*, 27(1):85–102, January 2003.
- [94] M. Kofler. *R-trees for Visualizing and Organizing Large 3D GIS Databases*. PhD thesis, Institute for Computer Graphics and Vision (ICGV), Graz University of Technology, Austria, 1998.
- [95] M.J. Kraak and F.J. Ormeling. *Cartography, Visualization of spatial data*. Addison Wesley, London, 1996.
- [96] S. Landes. *Funktionalität des internetbasierten 3D Campus Informations systems der Universität Karlsruhe*. PhD thesis, Institute für Photogrammetrie und Fernerkundung, Karlsruhe, 1999.
- [97] Laser-Scan Radius. Laser-Scan Radius Topology, 2004. [www.radius.laser-scan.com](http://www.radius.laser-scan.com).
- [98] Laser-Scan Radius Topology. Radius Topology Database Administrator's Guide, Issue 1.0 for Radius Topology Version 2.0. Technical report, Laser-Scan Limited, Cambridge, United Kingdom, April 2003.
- [99] R. Laurini. *Information Systems for Urban Planning, a Hypermedia Cooperative Approach*. Taylor and Francis, London, New York, 2001.

- [100] S.H. Lee and K. Lee. Partial Entity Structure: A compact non-manifold boundary representation based on partial topological entities. In *Proceedings Sixth ACM Symposium on Solid Modeling and Applications*, pages 159–170, Ann Arbor, Michigan, USA, June 2001.
- [101] C.H.J. Lemmen, P. van der Molen, P.J.M. van Oosterom, H. Ploeger, C.W. Quak, J.E. Stoter, and J.A. Zevenbergen. A modular standard for the Cadastral Domain. In *Proceedings of Digital Earth*, Brno, Czech Republic, September 2003.
- [102] C.H.J. Lemmen, E.P. Oosterbroek, and P.J.M. van Oosterom. Spatial data management in the Netherlands Cadastre. In *Proceedings of the FIG XXI International Congress, Commission 3, Land Information Systems*, pages 398–409, Brighton, United Kingdom, July 1998.
- [103] U. Lenk. Strategies for integrating height information and 2D GIS data. In *Proceedings of Joint OEEPE/ISPRS Workshop From 2D to 3D, establishment and maintenance of national core spatial databases*, Hannover, Germany, October 2001.
- [104] C. Lindenbeck and H. Ulmer. Geology meets virtual reality: VRML Visualisation Server Applications. In *Proceedings of WSCG'98 (sixth International conference in Central Europe on Computer Graphics and Visualization, Vol. III)*, pages 402–408, Plzen, Czech Republic, February 1998.
- [105] P.D. Lindstrom, W. Koller, W. Ribarsky, L. Hodges, N. Faust, and G.A. Turner. Real-time, continuous level of detail rendering of height fields. In *Proceedings of SIGGRAPH'96 (23rd annual conference on Computer Graphics and International Techniques)*, pages 109–118, New Orleans, Louisiana, USA, August 1996.
- [106] T.L. Logan and N.A. Bryant. Spatial data software integration: merging CAD/CAM/Mapping with GIS and image processing. *Photogrammetric Engineering and Remote Sensing*, 53(10):1391–1395, 1987.
- [107] L. Louwman. De inschrijving van netwerktekeningen (in Dutch). *De Stichting tot Bevordering der Notariële Wetenschap*, 6547:720–722, 2003.
- [108] J. Louwsma, T.P.M. Tijssen, and P.J.M. van Oosterom. A comparison between topologically structured and 'plain' spatial data. *Geoconnexion*, June 2003.
- [109] D.W. Lowe. Fitting parameterized three-dimensional models to images. *IEEE Transactions on Pattern Analysis and Machine Intelligence*, 13(5):441–450, May 1991.
- [110] H. Luttermann and M. Grauer. Using interactive, temporal visualizations for WWW-based presentation and exploration of spatio-temporal data. In *Proceedings of Spatio-Temporal Database Management 1999, International Workshop STDBM'99*, pages 100–118, Edinburgh, Scotland, September 1999.
- [111] D.J. Maguire. Improving CAD-GIS Interoperability , 2003. [www.esri.com/news/arcnews/winter0203articles/improving-cad.html](http://www.esri.com/news/arcnews/winter0203articles/improving-cad.html).



- 
- [112] D.J. Maguire, M.F. Goodchild, and D.W. Rhind. *Geographic Information Systems: principles and applications*. Longman Scientific and Technical, 1991.
- [113] MapInfo. Mapinfo, 2004. [www.mapinfo.com](http://www.mapinfo.com).
- [114] H. Mattsson. Towards Three Dimensional Properties in Sweden. In *Proceedings of European Faculty of Land Use and Development, 32nd International Symposium*, Strassbourg, France, October 2003.
- [115] F.H.J. Mijnsen, P. de Haan, and C. Asser. *Handleiding tot de beoefening van het Nederlands burgerlijk recht, Algemeen goederenrecht (in Dutch)*. Deventer, 2001.
- [116] E. Mitrofanova. The needs and possibilities for three-dimensional determination of real estate in Ukraine. In *Proceedings International Workshop on 3D Cadastres*, Delft, the Netherlands, November 2001.
- [117] P. van der Molen. De kadastrale registratie van ondergrondse bouwwerken (in Dutch). *VI Matrix*, February 1998.
- [118] M. Molenaar. Single valued vector maps: a concept in geographic information systems. *Geo-Informationssysteme*, 2(1):18–26, 1989.
- [119] M. Molenaar. A topology for 3D vector maps. *ITC Journal*, 1992(1):pp. 25–33, 1992.
- [120] M. Mortenson. *Geometric Modelling*. John Wiley & Sons, New York, USA, second edition, 1997.
- [121] S.M. Movafagh. GIS/CAD Convergence Enhances Mapping Applications. *GIS World*, 8(5):44–47, May 1995.
- [122] MySQL, 2004. [dev.mysql.com](http://dev.mysql.com).
- [123] S. Nebiker. Support for visualisation and animation in a scalable 3D GIS environment: motivation, concepts and implementation. In *Proceedings of ISPRS Commission V Working Group 6, Workshop on Visualization and Animation of Reality-based 3D Models*, Engadin, Switzerland, February 2003.
- [124] H. Netzel and F. Kaalberg. Settlement Risk Management with GIS for the North/South Metroline in Amsterdam. In *Proceedings of World Tunnel Congress*, Oslo, Norway, 1999.
- [125] R.G. Newell and T.L. Sancha. The difference between CAD and GIS. *Computer Aided Design*, 22(3):131–135, 1990.
- [126] S. Ng'ang'a, M. Sutherland, S. Cockburn, and S. Nichols. Towards a 3D marine cadastre in support of good ocean governance. In *Proceedings of International Workshop on 3D Cadastres, FIG*, pages 99–114, Delft, the Netherlands, 28-30 November 2001.
- [127] F. Nieper and H.D. Ploeger. *Sachenrecht in Europa (in German)*. Butterworths, Universitätsverlag Rash, Osnabrück, 1999.

- [128] E. van Nieuwburg. Visualisatie van 3D geo-informatie met VRML/X3D (in Dutch). Technical Report MSc case study report, TU Delft, Section GIS technology, 2003.
- [129] P.R. van Nieuwenhuizen and F.W. Jansen. Computer graphics lecture notes. Technical report, Delft University of Technology, Delft, the Netherlands, 2002.
- [130] NIST, 2004. [cic.nist.gov/vrml/vbdetect.html](http://cic.nist.gov/vrml/vbdetect.html).
- [131] NNI. Terreinmodel Vastgoed. Termen, definities en algemene regels voor de classificatie en codering van de aan het aardoppervlak gerelateerde objecten (in Dutch). Technical Report UDC 001.4:69:001.4:681.3.003.62, Nederlands Normalisatie Instituut, 1995.
- [132] D. Nebert (Technical Working Group Chair of Global Spatial Data Infrastructure). Developing Spatial Data Infrastructures: The SDI Cookbook, version 1.1, May 2001. [www.gsdi.org/pubs/cookbook/cookbook0515.pdf](http://www.gsdi.org/pubs/cookbook/cookbook0515.pdf).
- [133] H. Onsrud. Making laws for 3D cadastre in Norway. In *Proceedings FIG, ACSM/ASPRS*, Washington D.C., USA, April 2002.
- [134] P.J.M. van Oosterom. The GAP-tree, an approach to ‘On-the-Fly’ Map Generalization of an Area Partitioning. In Mü, J.P. Lagrange, and R. Weibel, editors, *GIS and Generalization, Methodology and Practice*, chapter 9, pages 120–132. Taylor & Francis, 1995.
- [135] P.J.M. van Oosterom. Research issues in integrated querying of geometric and thematic cadastral information (1 and 2). Technical Report GIST No. 1 and 4, Department of Geodesy, Delft University of Technology, Delft, the Netherlands, 2000.
- [136] P.J.M. van Oosterom and C.H.J. Lemmen. Spatial data management on a very large cadastral database. *Computers, Environments and Urban Systems (CEUS)*, 25(4-5):509–528, 2001.
- [137] P.J.M. van Oosterom, B. Maessen, and C.W. Quak. Spatial, thematic and temporal views. In *Proceedings of 9th International Symposium on Spatial Data Handling*, Beijing, China, 10-12 August 2000.
- [138] P.J.M. van Oosterom, B. Maessen, and C.W. Quak. Generic query tool for spatio-temporal data. *International Journal of Geographical Information Science*, 16(8):713–748, 2002.
- [139] P.J.M. van Oosterom, C.W. Quak, and T.P.M. Tijssen. Testing current DBMS products with real spatial data. In *Proceedings UDMS 2002*, Prague, Czech Republic, October 2002.
- [140] P.J.M. van Oosterom, C.W. Quak, and T.P.M. Tijssen. Polygons: the unstable foundation of spatial modeling. In *Proceedings ISPRS joint workshop on spatial, temporal and multi-dimensional data modelling and analysis*, Quebec, Canada, October 2003.

- 
- [141] P.J.M. van Oosterom and V. Schenkelaars. The Development of an Interactive Multi-Scale GIS. *International Journal of Geographical Information Science*, 9(5):489–507, 1995.
- [142] P.J.M. van Oosterom, J.E. Stoter, and E.M. Fendel, editors. *Registration of properties in strata: International Workshop on 3D Cadastres*, Delft, the Netherlands, October 2001.
- [143] P.J.M. van Oosterom, J.E. Stoter, and F. Jansen. *Bridging the worlds of CAD and GIS*, chapter 1. 2004.
- [144] P.J.M. van Oosterom, J.E. Stoter, W.C. Quak, and S. Zlatanova. The balance between geometry and topology. In D. Richardson and P.J.M. van Oosterom, editors, *Proceedings of 10th International Symposium on Spatial Data Handling*, Ottawa, Canada, July 2002.
- [145] P.J.M. van Oosterom, J.E. Stoter, E. Verbree, and S. Zlatanova. 3D GIS komt er wel, maar 't zal wel even duren (in Dutch). *VI Matrix*, 10(3):20–23, May 2002.
- [146] P.J.M. van Oosterom, J.E. Stoter, E. Verbree, and S. Zlatanova. Onderzoek brengt 3D GIS in gangbare geo-informatie naderbij (in Dutch). *VI Matrix*, 10(5):26–29, September 2002.
- [147] P.J.M. van Oosterom, W. Vertegaal, M. van Hekken, and T. Vijlbrief. Integrated 3D modelling within a GIS. In *Proceedings of Advanced Geographic Data Modelling: spatial data modelling and query languages for 2D and 3D applications*, pages 80–95, Delft, the Netherlands, September 1994.
- [148] OpenGIS Consortium. OpenGIS Simple Features Specification for SQL. Technical Report Revision 1.1, OpenGIS Project Document 99-049, OpenGIS Consortium, Wayland, Mass., VS, 1999.
- [149] OpenGIS Consortium. OGC Web Terrain Server (WTS), version 0.3.2. Technical Report OGC 01-061, Wayland, Mass., VS, 2001.
- [150] OpenGIS Consortium. OpenGIS Abstract and Implementation Specifications, 2001. [www.opengis.org/techno/specs.htm](http://www.opengis.org/techno/specs.htm).
- [151] OpenGIS Consortium. Request Number 12, Geometry Working Group, A request for Proposals: OpenGIS Feature Geometry. Technical report, Wayland, Mass., VS, 2001.
- [152] OpenGIS Consortium. The OpenGIS Abstract Specification, Topic 1: Feature Geometry (ISO 19107 Spatial Schema), Version 5. Technical Report OpenGIS Project Document Number 01-101, Wayland, Mass., VS, 2001.
- [153] OpenGIS Consortium. Web Map Service Implementation Specification, version 1.1.1. Technical Report OGC 01-068r2, Wayland, Mass., VS, 2001.
- [154] OpenGIS Consortium. Web Feature Service Implementation Specification, version 1.0.0. Technical Report OGC 02-058, Wayland, Mass., VS, 2002.

- [155] OpenGIS Consortium. OpenGIS Geography Markup Language (GML) Implementation Specification. Technical Report 02-023r4, Wayland, Mass., VS, 2003.
- [156] OpenGIS Consortium. OpenGIS Reference Model. Technical report, Wayland, Mass., VS, 2003.
- [157] OpenGIS Consortium. OpenGIS Web Map Server Cookbook. Technical Report 03-050r1, Wayland, Mass., VS, 2003.
- [158] OpenGIS Consortium. Web Coverage Service (WCS), version 1.0.0. Technical Report OGC 03-065r6, Wayland, Mass., VS, 2003.
- [159] OpenGIS Consortium. OGC, 2004. [www.opengis.org](http://www.opengis.org).
- [160] ORACLE. Oracle spatial user's guide and reference release 9.2 part number a96630-01. Technical report, ORACLE, March, 2002.
- [161] A. Osskó. Problems in registration in the third vertical dimension in the unified Land Registry in Hungary, and possible solution. In *Proceedings International Workshop on 3D Cadastres*, pages 305–314, Delft, the Netherlands, November 2001.
- [162] W. Pasman and F.W. Jansen. Scheduling Level of Detail with Guaranteed Quality and Cost. In *Proceedings of 7th International Conference on 3D Web Technology*, pages 43–51, Tempe, Arizona, February 2002.
- [163] W. Pasman, A. van der Schaaf, R.L. Lagendijk, and F.W. Jansen. Low latency rendering and positioning for mobile augmented reality. In *Proceedings of Vision Modeling and Visualization '99*, pages 309–315, Erlangen, Germany, November 1999.
- [164] R. Passini and D. Betzner. Filtering of digital elevation models. In *Proceedings FIG, ACSM/ASPRS*, Washington D.C. USA, April 2002.
- [165] PCIGEMATICS, 2004. [www.pcigeomatics.com](http://www.pcigeomatics.com).
- [166] W. Peng. *Automated Generalization in GIS*. PhD thesis, Wageningen University, ITC, the Netherlands, 1997.
- [167] F. Penninga. Detectie van kenmerkende hoogtepunten in TIN's voor iteratieve datareductie (in Dutch). In *Proceedings of Geo-Informatiedag Nederland 2002*, Ede, the Netherlands, February 2002.
- [168] S. Pigot. *A topological model for a 3-dimensional Spatial Information System*. PhD thesis, University of Tasmania, Australia, 1995.
- [169] M. Pilouk. *Integrated modeling for 3D GIS*. PhD thesis, Wageningen University, ITC, the Netherlands, 1996.
- [170] E. Pogorelčnik and M. Korošec. Land Cadastre and Building Cadastre in Slovenia: Current situation and potential of 3D data. In *Proceedings International Workshop on 3D Cadastres*, pages 79–90, Delft, the Netherlands, November 2001.

- 
- [171] PostGIS. PostGIS Manual, 2002. [postgis.refractor.net/docs](http://postgis.refractor.net/docs).
- [172] PostgreSQL, 2004. [www.postgresql.org](http://www.postgresql.org).
- [173] C.W. Quak, T.P.M. Tijssen, and J.E. Stoter. Topology in Spatial DBMSs. In *Proceedings of Digital Earth*, Brno, Czech Republic, September 2003.
- [174] Queensland Government. *Land Title Act 1994, reprinted as in force on 16 May 2003*. Queensland, Australia, 2003.
- [175] Queensland Government. *Registrar of titles directions for the preparation of plans*. Queensland, Australia, 2003.
- [176] R. Ramakrishnan and J. Gerhke. *Database Management Systems*. McGraw-Hill Higher Education, 2003.
- [177] D.E. Richardson. *Automated Spatial and Thematic Generalization using a Context Transformation Model*. PhD thesis, Wageningen University, 1993.
- [178] P. Rigaux, M. Scholl, and A. Voisard. *Spatial Databases with applications to GIS*. Morgan Kaufmann, San Diego, USA, 2001.
- [179] Rijksdienst voor de Monumentenzorg, 2004. [www.monumentenzorg.nl](http://www.monumentenzorg.nl).
- [180] *Rijksdienst voor Monumentenzorg and Rijksdienst voor Oudheidkundig Bodemonderzoek*. Actualisering monumentenregister, 2004. [www.amr.nl](http://www.amr.nl).
- [181] R. Rijkers, M. Molenaar, and J. Stuiver. A query oriented implementation of a 3D topological data structure. In *Proceedings of EGIS'93*, pages 1411–1420, Genoa, Italy, 1993.
- [182] G. Roberts, A. Evans, A. Dobson, B. Denby, S. Cooper, and R. Hollands. Look beneath the surface with augmented reality. *GPS World*, February 2002.
- [183] J. Ruppert. A Delaunay Refinement Algorithm for Quality 2-Dimensional Mesh Generation. *Journal of Algorithms*, 18(3):548–585, 1995.
- [184] M. Saadi Mesgari. *Topological cell-tuple structures for three-dimensional spatial data*. PhD thesis, University of Twente, ITC, the Netherlands, 2000.
- [185] A. Schutzberg. Bringing GIS to CAD: A Developer's Challenge. *GIS World*, 8(5):48–54, May 1995.
- [186] S. Shekhar and S. Chawla. *Spatial Databases, a tour*. Prentice Hall, New Jersey, USA, 2003.
- [187] I.D.H Shepherd. Mapping with desktop CAD: A critical review. *Computer Aided Design*, 22(3):136–150, 1990.
- [188] J.R. Shewchuk. Triangle: Engineering a 2D Quality Mesh Generator and Delaunay Triangulator. In *Proceedings of First Workshop on Applied Computational Geometry*, pages 124–133, Philadelphia, Pennsylvania, USA, May 1996.
- [189] J.R. Shewchuk. The Quake Project, 2004. [www-2.cs.cmu.edu/~quake](http://www-2.cs.cmu.edu/~quake).

- [190] W.Z. Shi, B.S. Yang, and Q.Q. Li. An Object-Oriented Data Model for Complex Objects in Three-Dimensional Geographic Information Systems. *International Journal of Geographical Information Science*, 17(5):411–430, 2003.
- [191] S.R. Simpson. *Land law and registration, Book 1*. Surveyor Publications, London, 1984.
- [192] J.W.N. van Smaalen. *Automated Aggregation of Geographic Objects, A new approach to the Conceptual Generalisation of Geographic Databases*. PhD thesis, TU Delft, ITC, the Netherlands, 2003.
- [193] A.P. Smith, M. Dodge, and S. Doyle. Visual Communication in Urban Planning and Urban Design, report to the Advisory Group on Computer Graphics. Technical Report CASA paper 2, 1998.
- [194] H.J. Snijders and E.B. Rank-Berenschot. *Goederenrecht (in Dutch)*. Kluwer, Deventer, 2001.
- [195] M. Stonebraker. *Object-Relational DBMSs The Next Great Wave*. Morgan Kaufmann, San Francisco, CA, 1996.
- [196] J.E. Stoter. 3D aspects of property transactions: comparison of registration of 3D properties in the Netherlands and Denmark. Technical Report GIST No. 24, Research Institute for Housing, Urban and Mobility Studies, November 2003.
- [197] J.E. Stoter and B.Gorte. Height in the cadastre, integrating point heights and parcel boundaries. In *Proceedings FIG Working Week*, Paris, France, April 2003.
- [198] J.E. Stoter and P.J.M. van Oosterom. Incorporating 3D geo-objects into a 2D geo-DBMS. In *Proceedings FIG, ACSM/ASPRS*, Washington D.C. USA, April 2002.
- [199] J.E. Stoter, F. Penninga, and P.J.M. van Oosterom. Generalization of integrated terrain elevation and 2D object models. In *Proceedings of 11th International Symposium on Spatial Data Handling*, Leicester, UK, August 2004.
- [200] J.E. Stoter and H.D. Ploeger. Multiple use of space: current practice of registration and development of a 3D cadastre. In *Proceedings UDMS 2002*, Prague, Czech Republic, October 2002.
- [201] J.E. Stoter and H.D. Ploeger. Registration of 3D objects crossing parcel boundaries. In *Proceedings FIG Working Week*, Paris, France, April 2003.
- [202] J.E. Stoter and M. Salzmann. Where do cadastral needs and technical possibilities meet? *Computers, Environments and Urban Systems (CEUS)*, 27(4):395–410, 2003.
- [203] J.E. Stoter, E.M. Sørensen, and L. Bodum. 3D registration of real property in Denmark. In *Proceedings of FIG Working Week*, Athens, Greece, May 2004.
- [204] J.E. Stoter and S. Zlatanova. 3D GIS where are we standing? In *Proceedings ISPRS Workshop on spatial, temporal and multi-dimensional data modelling and analysis*, Quebec, Canada, October 2003.

- 
- [205] J.E. Stoter and S. Zlatanova. Visualising and editing of 3D objects organised in a DBMS. In *Proceedings of EuroSDR Com V Workshop on Visualisation and Rendering*, Enschede, the Netherlands, January 2003.
- [206] M. Sun, J. Chen, and A. Ma. Construction of Complex City Landscape with the support of CAD. In *Proceedings International Workshop on Visualization and Animation Of Landscape*, Kunming, China, February 2001.
- [207] I. Suveg and M.G. Vosselman. Automatic 3D reconstruction of buildings. In *Proceedings of SPIE Photonics West, Electronic Imaging, Three-dimensional Image Capture and Applications V, conference 4661*, pages 59–69, San Jose, California, USA, 2002.
- [208] Swedish Government. Tredimensionell fastighetsindelning (in Swedish), 2004. [justitie.regeringen.se/sb/d/1917/a/12244](http://justitie.regeringen.se/sb/d/1917/a/12244).
- [209] P.J.G. Teunissen. *Adjustment theory, an introduction*. Delft University Press, Deventer, 2003.
- [210] W.J.M. Teunissen and P.J.M. van Oosterom. The creation and display of arbitrary polyhedra in HIRASP. Technical Report 88-20, University of Leiden, Leiden, the Netherlands, 1988.
- [211] M.D. Thomas. *Oracle XSQL: Combining SQL, Oracle Text, XSLT, and Java to Publish Dynamic Web Content*. Wiley Europe, West Sussex, UK, 2003.
- [212] L. Ting and I.P. Williamson. Cadastral trends: A synthesis. *The Australian Surveyor*, 4(1):46–54, 1999.
- [213] D.C. Tsichritzis and F.H. Lochovsky. *Data models*. Prentice-Hall International, New Jersey, USA, 1982.
- [214] J. Ullman and J. Widom. *A first course in database systems, second edition*. Prentice-Hall, New Jersey, USA, 2001.
- [215] UML. OMG Unified Modeling Language Specification, Version 1.5. Technical Report formal/03-03-01, An Adopted Formal Specification of the Object Management Group, 2003.
- [216] Valetta Convention. European Convention on the Protection of the Archaeological Heritage, Council of Europe, 1992. [conventions.coe.int/Treaty/en/Treaties/Html/143.htm](http://conventions.coe.int/Treaty/en/Treaties/Html/143.htm).
- [217] T. Valstad. The Oslo Method: a practical approach to register 3D properties. In *Proceedings FIG Working Week 2003*, Paris, France, April 2003.
- [218] A.A. van Velten. De eigendom van ondergrondse telecomnetten (in Dutch). *Weekblad voor Privaatrecht, Notariaat en Registratie*, 6285:667–671, 1997.
- [219] E. Verbree, G. van Maren, F. Jansen, and M. Kraak. Interaction in virtual world views, linking 3D GIS with VR. *International Journal of Geographical Information Science*, 13(4):385–396, 1999.

- [220] E. Verbree and P.J.M. van Oosterom. The STIN method: 3D surface reconstruction by observation lines and Delaunay TENSs. In *Proceedings of ISPRS Workshop on 3D-reconstruction from airborne laserscanner and InSAR data*, Dresden, Germany, October 2003.
- [221] T. Vijlbrief and P.J.M. van Oosterom. GEO++: An extensible GIS. In *Proceedings of 5th International Symposium on Spatial Data Handling*, Charleston, South Carolina, USA, August 1992.
- [222] G. Vosselman. Building reconstruction using planar faces in very high density height data. In *ISPRS Conference on Automatic Extraction of GIS Objects from Digital Imagery*, pages 87–92, Munich, Germany, September, 1999.
- [223] G. Vossen. *Data models, database languages and database management systems*. Addison-Wesley, Wokingham, UK, 1991.
- [224] J. de Vries. 3D GIS en grootschalige toepassingen, de opslag en analyse in een geïntegreerde drie-dimensionale GIS (in Dutch). Technical Report MSc thesis, Delft University of Technology, Delft, the Netherlands, 2001.
- [225] M.E. de Vries and J.E. Stoter. Accessing a 3D geo-DBMS using Web technology. In *Proceedings ISPRS Workshop on spatial, temporal and multi-dimensional data modelling and analysis*, Quebec, Canada, October 2003.
- [226] M.E. de Vries and S. Zlatanova. Interoperability on the WEB: The case of 3D geo-data. In *Proceedings IADIS International Conference e-Society*, Avila, Spain, July 2004.
- [227] X. Wang and A. Grünen. A hybrid GIS for 3-D city models. *International Archives of Photogrammetry and Remote Sensing*, (4/3):1165–1172, 2000.
- [228] J. Warmer and A. Kleppe. *The Object Constraint Language: Precise Modeling with UML*. Addison-Wesley, 1998.
- [229] Web3D Consortium. X3D, Open Standards for Real-Time 3D Communication, 2004. [www.web3d.org/fs\\_specifications.htm](http://www.web3d.org/fs_specifications.htm).
- [230] J.D. Wees, R.W. Versseput, H.J. Simmelink, R.R.L. Allard, and H.J.M. Pagnier. Shared Earth system models for the Dutch subsurface. In *Proceedings GIN 2002, Geoinformatiedag Nederland 2002*, Ede, February 2002.
- [231] M. Werner. Integrating GIS with inundation models for flood extent mapping. In *Proceedings UDMS 2002*, Prague, Czech Republic, October 2002.
- [232] M.S. Widodo. The needs for marine cadastre and supports of spatial data: Infrastructures in marine environment-a case study. In *Proceedings FIG Working Week 2003*, Paris, France, April 2003.
- [233] M.F. Worboys. Object-oriented models of spatio-temporal information. In *Proceedings of GIS/LIS'92*, pages 825–834, San José, California, USA, 1992.
- [234] M.F. Worboys. *Geographical Information Systems: A computing perspective*. Taylor and Francis, London, 1995.



- 
- [235] L. Yaolin. *Categorical Database Generalization in GIS*. PhD thesis, Wageningen University, ITC, the Netherlands, 2002.
- [236] J.A. Zevenbergen. Are cadastres really serving the landowner. In *Proceedings UDMS 1999*, Venice, Italy, April 1999.
- [237] J.A. Zevenbergen. *Systems of Land Registration, Aspects and Effects*. PhD thesis, TU Delft, the Netherlands, 2001.
- [238] J.A. Zevenbergen and J. de Jong. Public Law Information Regarding Land; Dutch proposal for registration. In *Proceedings FIG, ACSM/ASPRS*, Washington D.C. USA, April 2002.
- [239] A. Zipf and R. Leiner. Mobile GIS based Flood Warning and Information System. In *Proceedings of Symposium on LBS and TeleCartography*, Vienna, Austria, January 2004.
- [240] S. Zlatanova. *3D GIS for Urban Development*. PhD thesis, Institute for Computer Graphics and Vision (ICGV), Graz University of Technology, Austria, ITC, the Netherlands, 2000.
- [241] S. Zlatanova. Augmented Reality Technology, Report for SURFnet. Technical Report GIS<sub>t</sub> No. 18, Department of Geodesy, Delft University of Technology, Delft, the Netherlands, 2002.
- [242] S. Zlatanova, A. Rahman, and M. Pilouk. 3D GIS: current status and perspectives. In *Proceedings of ISPRS*, Ottawa, Canada, July 2002.
- [243] S. Zlatanova, A.A. Rahman, and W. Shi. Topology for 3D spatial objects. In *Proceedings International Symposium and Exhibition on Geoinformation 2002*, Kuala Lumpur, Malaysia, October 2002.
- [244] S. Zlatanova and E. Verbree. A 3D topological model for augmented reality. In *Proceedings Mobile MultiMedia Systems and Applications, MMSA*, Delft, the Netherlands, 2000.



# Appendix A

## Visualising attributes in VRML

The interaction with 3D objects in a VRML file has to be explicitly described in the VRML. This can be organised by two additional VRML nodes. First, a particular sensor (e.g. TouchSensor) has to be attached to the object (a Shape), which will monitor whether the cursor interacts with the object. Second, a billboard node has to be introduced to visualise the attributes in text format. In this example, a new 'proto' node has been designed. The node is a TouchSensor extended with a Javascript code (included in the VRML file), which controls the text that is visualised (in this case attribute information). The code provides a link between the attributes and the geometry. This link needs to be defined for every object using the specific code. The VRML code for the example of figure 8.6 is shown below.

```
#VRML V2.0 utf8

Background {
  skyColor [
    0.0 0.2 0.7,
    0.0 0.5 1.0,
    1.0 1.0 1.0
  ]
  skyAngle [ 1.009, 1.571 ]
}

PROTO TOUCH [
  field          SFInt32          object 0
  eventOut       MFString        string_changed
]

{
  DEF SENS TouchSensor {}
  DEF NODE Script {
    url "javascript:
      function set_boolean (bool)
      {
        if ((bool == true)&&(object == 30))
          string_changed [0] = 'BUILDING /34';
        if ((bool == false)|| (object == 0))
          string_changed [0] = '';
      }"
    eventIn SFBool set_boolean
    eventOut MFString string_changed IS string_changed
    field SFInt32 object IS object
  }
  ROUTE SENS.isOver TO NODE.set_boolean
}#TOUCH
```

```
Transform {
  translation 0 0 -30
  children [
    DEF Box30 TOUCH {
      object 30
    }
    Shape {
      appearance Appearance {
        material Material {
          diffuseColor 0.60 0 0
        }
      }
      geometry Box {
        size 4 4 4
      }
    }
    Transform {
      translation 4 4 4
      children[
        Billboard {
          children [
            Shape {
              appearance Appearance {
                material Material {
                  diffuseColor 0 0 0
                }
              }
              geometry DEF TEXT30 Text {
                length [5,120]
              }
            }
          ]
          axisOfRotation 0.0 1.0 0.0
        }
      ]
    }
  ]
}
]]

ROUTE Box30.string_changed TO TEXT30.string_changed
```

# Appendix B

## XSLT stylesheet to transform XML to X3D

When a Web Server receives a request for an XSQL document, the page is passed to the XSQL servlet. The page is processed by the servlet: a connection to the database is made and the select statement is sent to the DBMS. The result set that comes back from the database is in XML format. The second step is then to transform the 'raw' XML stream into a X3D or VRML output stream. Because of the XML syntax of X3D, the transformation from Oracle to X3D can easily be handled by XSLT stylesheets. The XSLT stylesheet below shows how to convert the XML output of Oracle in case of multipolygons to an X3D format.

```
<?xml version="1.0" encoding="iso-8859-1" ?>
<xsl:stylesheet version="1.0" xmlns:xsl="http://www.w3.org/1999/XSL/Transform" >
<xsl:output method="xml" indent="no" media-type="model/x3d+xml" encoding="iso-8859-1" />

<!-- arguments for construction of getfieldinfo url -->
<xsl:param name="table" />
<xsl:param name="idcol" />
<xsl:param name="con" />

<!-- other variables -->
<xsl:variable name="apos">'</xsl:variable>
<xsl:variable name="zdummy">0</xsl:variable>

<xsl:template match="mymap">

  <!-- print outer x3d elements -->
  <X3D version='3.0' profile="Interactive">
    <Background skyColor="1 1 1" />
    <Scene>

      <!-- transform data in inputstream from XML to x3d -->
      <xsl:apply-templates />

    </Scene>
  </X3D>
</xsl:template>

<xsl:template match="ROW/*[SDO_GTYPE='3003' or SDO_GTYPE='3004' or SDO_GTYPE='3007']">

  <!-- get start positions in sdo_ordinates array of exterior and interior rings -->
  <xsl:variable name="startAt" >
    <xsl:for-each select="SDO_ELEM_INFO/SDO_ELEM_INFO_ITEM[position() mod 3 = 1]" >
```

```

        <xsl:value-of select="concat(';',.,';')" />
    </xsl:for-each>
</xsl:variable>

<!-- construct Anchor, Shape and IndexedFaceSet -->
<Anchor parameter='target=new'>
  <xsl:attribute name="url">
    <xsl:if test="../ID and ../ID!='dummy'">
      <xsl:variable name="oid" select="../ID" />
      <xsl:text>fieldinfo.xsql?table=</xsl:text>
      <xsl:value-of select=
        'concat($table, "&idcol=", $idcol, "&id=", ../ID, "&con=" , $con)'
      />
    </xsl:if>
  </xsl:attribute>

  <Shape>
    <IndexedFaceSet>
      <xsl:attribute name="convex">false</xsl:attribute>
      <xsl:attribute name="solid">false</xsl:attribute>

      <!-- construct coordIndex= -->
      <xsl:attribute name="coordIndex">
        <xsl:call-template name="creCoordIndex" >
          <xsl:with-param name="startAt" select="$startAt" />
          <xsl:with-param name="triplet" select="0" />
          <xsl:with-param name="total" select="count(SDO_ORDINATES/SDO_ORDINATES_ITEM)" />
        </xsl:call-template>
      </xsl:attribute>

      <!-- construct Coordinate point= -->
      <Coordinate>
        <xsl:attribute name="point">
          <xsl:call-template name="MLSegment3d" >
            <xsl:with-param name="startAt" select="$startAt" />
          </xsl:call-template>
        </xsl:attribute>
      </Coordinate>
    </IndexedFaceSet>

    <!-- print rest of x3d tags -->
    <Appearance>

      <xsl:variable name="difcolor">
        <xsl:choose>
          <xsl:when test="SDO_GTYPE='3003'">1 0 0</xsl:when>
          <xsl:when test="SDO_GTYPE='3004'">0 1 0</xsl:when>
          <xsl:when test="SDO_GTYPE='3007'">0 0 1</xsl:when>
          <xsl:otherwise>0 0 0</xsl:otherwise>
        </xsl:choose>
      </xsl:variable>

      <Material>
        <xsl:attribute name="diffuseColor"><xsl:value-of select="$difcolor"/></xsl:attribute>
        <xsl:attribute name="ambientIntensity">1</xsl:attribute>
        <xsl:attribute name="specularColor">0.8 0.8 0.8</xsl:attribute>
        <xsl:attribute name="transparency">0.0</xsl:attribute>
      </Material>

    </Appearance>
  </Shape>
</Anchor>

</xsl:template>

<xsl:template name="MLSegment3d">
  <xsl:param name="startAt" />

  <xsl:for-each select="SDO_ORDINATES/SDO_ORDINATES_ITEM">
    <!-- ... routine to print xyz-coordinates ... -->

```

```
</xsl:for-each>
</xsl:template>
<xsl:template name="creCoordIndex">
  <xsl:param name="startAt" />
  <xsl:param name="triplet" />
  <xsl:param name="total" />

  <xsl:variable name="ordinate" select="($triplet*3)+1" />
  <xsl:variable name="lookFor" select="concat(';', $ordinate, ';')"/>

  <!-- ... routine to create coordinate index ... -->
</xsl:template>
<xsl:template match="ROW/*[count(SDO_GTYPE)=0]" >
  <!-- skip non-spatial properties -->
</xsl:template>
<xsl:template match="text()" >
  <!-- skip text output -->
</xsl:template>
</xsl:stylesheet>
```





# Nederlandse samenvatting

## 3D Kadaster

In veel kadastrale registraties is het perceel, dat begrensd is door middel van tweedimensionale perceelsgrenzen, de basiseenheid voor de registratie van vastgoed. Het recht op een perceel geeft het recht om het gehele volume boven en onder het perceel te gebruiken. Een eigendom op een 2D perceel is dus eigenlijk een 3D eigendom. Zolang er zich slechts één gebruiker op een perceel bevindt, is de huidige kadastrale registratie door middel van de 2D kadastrale kaart zeer goed in staat om inzicht te verschaffen in de eigendomssituatie. Problemen doen zich echter voor in 3D eigendomssituaties. In dit proefschrift wordt met een 3D eigendomssituatie bedoeld dat verschillende personen ruimtes boven en onder elkaar gebruiken. Deze ruimtes kunnen volledig binnen één perceel vallen (bijvoorbeeld een winkel onder een appartementen-complex). Maar het kan ook zijn dat de gestapelde en in elkaar grijpende ruimtes perceelsgrenzen overschrijden (bijvoorbeeld in het geval van een tunnel).

De onderzoeksvraag die centraal staat in dit proefschrift over 3D kadaster is: ‘op welke wijze kan een kadastrale registratie inzicht verschaffen in 3D eigendomssituaties?’. In dit onderzoek wordt gekeken of het 2D perceel als de basiseenheid van de kadastrale registratie nog steeds voldoet (en ook in de toekomst zal blijven voldoen) om eigendom van vastgoed inzichtelijk te maken, of dat dit uitgangspunt aangepast zou moeten worden vanwege een toenemende interesse in multifunctioneel ruimtegebruik. Om deze vraag te beantwoorden is dit proefschrift onderverdeeld in vier onderdelen:

- achtergrondanalyse;
- technisch kader voor het modelleren van 2D en 3D situaties;
- modellen voor een 3D kadaster;
- realisatie van een 3D kadaster.

### Achtergrondanalyse

In de achtergrond analyse zijn zowel de Nederlandse als de buitenlandse kadastrale registratie van 3D eigendommen onderzocht met als doel om een duidelijk overzicht te krijgen van de vereisten, maar ook van de stand van zaken betreffende een 3D kadastrale registratie. De belangrijkste conclusies die getrokken kunnen worden uit deze achtergrondanalyse zijn de volgende. In veel landen wordt, net als in Nederland, het eigendom op ruimtes boven en onder de grond altijd gerelateerd aan één of

meerdere grondperce(e)l(en). Dientengevolge is het eigendom op grondpercelen goed vastgelegd en goed zichtbaar in de kadastrale registratie. Maar wanneer men inzicht wil krijgen in eigendommen boven en onder de grond moet men de doorsneden grondpercelen raadplegen. De kadastrale registratie geeft echter alleen informatie over wie er welke rechten hebben op de doorsneden percelen. Wil men weten hoe deze rechten zijn verdeeld in de ruimte, dan kan men de akten behorende bij de rechten raadplegen. Men zal echter veelal de werkelijke situatie moeten bezoeken om te zien hoe de eigendommen daadwerkelijk zijn verdeeld over de ruimte.

In het buitenland zijn een aantal voorbeelden gevonden waar men naast 2D percelen ook percelen kan inschrijven die in de derde dimensie begrensd zijn en die niet zijn gerelateerd aan grondpercelen (Noorwegen, Zweden, Queensland (Australië) en Brits Colombia (Canada)). Hoewel deze 3D percelen veel potenties bieden voor een 3D kadaster, zijn ook deze voorbeelden geen complete 3D kadaster oplossingen. De grootste nadelen zijn dat de 3D situaties alleen zijn vastgelegd op afzonderlijke 3D veldwerken, welke gescand of analoog zijn opgeslagen. Hierdoor is het onmogelijk twee aangrenzende 3D percelen in één visualisatie te bevragen. Bovendien kunnen de 3D percelen niet gevalideerd worden (is de geometrische beschrijving gesloten?) en kan er niet in het 3D model worden genavigeerd, wat een belangrijk hulpmiddel is om ingewikkelde 3D percelen te kunnen begrijpen.

Uit de achtergrondanalyse kan worden geconcludeerd dat de belangrijkste behoeften voor een 3D kadaster als volgt omschreven kunnen worden:

- Het hebben van een complete registratie van 3D rechten. Dit zijn zakelijke rechten die personen het recht geven om een ruimte te gebruiken. Een 3D kadaster zou expliciet de ruimte moeten registreren waarop een persoon rechten heeft.
- Het hebben van een goede toegang tot de wettelijke status van vastgoed in de derde dimensie maar ook tot de publiekrechtelijke beperkingen die op ruimtes rusten.

Een 3D kadaster moet daarom twee belangrijke functionaliteiten ondersteunen:

- Het registreren van de ruimtes waar zakelijke rechten betrekking op hebben en deze informatie op een eenvoudige manier toegankelijk maken voor iedere geïnteresseerde.
- Het onderhouden van verbindingen met databases van objecten met een 3D component die van belang zijn voor het kadaster binnen een Geo-Informatie Infrastructuur (kabels en leidingen, bodemvervuilingen, natuurgebieden, monumenten) en deze informatie gebruiken in en toegankelijk maken via de kadastrale registratie.

### **Technisch kader voor het modelleren van 2D en 3D situaties**

Een 3D kadaster zal uiteindelijk gerealiseerd moeten worden met behulp van de techniek. Daarom is in het tweede deel gekeken naar wat er technologisch mogelijk is om 2D en 3D situaties te modelleren in een DBMS (DataBase Management Systeem) omgeving en hoe deze informatie toegankelijk kan worden gemaakt. Het DBMS heeft een belangrijke plaats binnen dit onderzoek naar technische mogelijkheden, omdat het DBMS in de nieuwe GIS architectuur centraal staat. In dit deel zijn bestaande

technieken bestudeerd en is gekeken naar tekortkomingen binnen huidige technieken. Tevens zijn er concepten ontwikkeld om tegemoet te komen aan deze tekortkomingen en zijn deze concepten vertaald in prototypes om te laten zien wat de mogelijkheden en beperkingen zijn voor 2D en 3D modellering. De belangrijkste conclusies die uit dit deel getrokken kunnen worden zijn de volgende.

Het geometrisch model is tot en met de tweede dimensie goed geïmplementeerd in object relationele DBMS-en. Het zal echter nog enkele jaren duren voordat de 2D topologische structuur ook op een eenduidige manier zal worden ondersteund. Recente implementaties op de markt gekomen voor de ondersteuning van 2D topologie in DBMS-en (Laser-Scan Radius Topology en Oracle 10g).

Op het gebied van 3D, zowel geometrisch als topologisch, is er nog erg weinig ondersteuning te vinden in huidige DBMS-en. Hoewel er al veel onderzoek gedaan is naar 3D modellen is er nog maar weinig geïmplementeerd. Om te laten zien of en in hoeverre 3D ondersteuning in DBMS-en mogelijk is, is in dit onderzoek een 3D primitieve (een polyhedron) in een DBMS geïmplementeerd (in Oracle Spatial). Deze implementatie laat zien dat het in principe mogelijk is om 3D objecten geometrisch vast te leggen in een DBMS, inclusief 3D validatie functies, een 3D index en ruimtelijke functies die werken in 3D.

De 3D objecten die staan opgeslagen in een DBMS kunnen worden gevisualiseerd en bevroegd door middel van front-ends. In dit onderzoek zijn experimenten gedaan met een CAD front-end, een GIS front-end en een zelf-geïmplementeerde Web applicatie. De experimenten met deze front-ends hebben laten zien dat een database gevuld met 3D objecten, op een klein aantal complicaties na, goed ontsloten kan worden.

Om 3D objecten te kunnen combineren met 2D percelen is een casestudie uitgevoerd die laat zien dat het mogelijk is een effectief TIN (Triangular Irregular Network) te genereren dat gebaseerd is op hoogte punten en perceelsgrenzen.

Ook is in dit deel bestudeerd hoe ver de ontwikkelingen zijn op het gebied van 3D GIS, omdat 3D GIS de aangewezen omgeving is waar 3D geo-objecten kunnen worden opgeslagen, geanalyseerd, geëdit en bevroegd. Uit deze studie blijkt dat een fundamentele doorbraak van 3D GIS voorlopig nog uitblijft, ook al is '3D' al zeker tien jaar een onderwerp dat veel belangstelling wekt in de GIS wereld. Tot nu toe zijn de implementaties beperkt tot visualisaties. Voor een echte doorbraak van 3D GIS zijn, naast een ondersteuning van 3D geometrische en topologische primitieven in DBMS-en, verbeteringen nodig op het gebied van 3D object reconstructie, visualisatie en navigatie in 3D modellen, 3D ruimtelijke analyses en het editten van 3D omgevingen.

### **Modellen voor een 3D kadaster**

Op basis van de achtergrondanalyse en de technische mogelijkheden die in de eerste twee delen zijn bestudeerd, zijn in dit deel verschillende modellen voor een 3D kadaster geïntroduceerd. Deze modellen zijn geëvalueerd om tot de beste oplossingen te komen voor een 3D kadaster. De modellen, met hun alternatieven, die in dit deel zijn geïntroduceerd, zijn (in het proefschrift zijn ook de UML klasse diagrammen van de verschillende modellen beschreven):

- Volledig 3D kadaster:
  - Alternatief 1: Combinatie van niet-gesloten (zowel onder als boven) perceelskolommen, volume percelen en rest percelen die overblijven nadat er

een volume perceel binnen de perceelskolom is gevestigd. De niet-gesloten perceelskolommen zijn in 2D afgebakend door traditionele perceelsgrenzen en zijn dus eigenlijk gelijk aan de traditionele 2D percelen met maar één gebruiker.

- Alternatief 2: Slechts één soort percelen wordt ondersteund: een perceel dat volledig gedefinieerd wordt in 3D. Men kan alleen rechten op een afgebakende ruimte krijgen en niet langer op een niet-gesloten perceelskolom (afgebakend door 2D perceelsgrenzen).
- Hybride kadaster:
  - Alternatief 1: Alle gevallen van vastgoed worden geregistreerd op 2D percelen, waarbij rechten die betrekking hebben op een ruimte ook als zodanig kunnen worden geregistreerd, inclusief een 3D omschrijving. Deze 3D rechts-volumes worden geïntegreerd met de kadastrale geografische dataset.
  - Alternatief 2: Alle gevallen van vastgoed worden geregistreerd op 2D percelen, maar het is in deze registratie mogelijk om fysieke objecten in te schrijven en te integreren met de kadastrale dataset. De wettelijke status van de fysieke objecten kan alleen worden vastgelegd door middel van de doorsneden percelen.
- 3D kadaster waarbij verwijzingen naar een 3D situatie kunnen worden opgenomen. Aan een perceel hangt een indicatie van een 3D situatie, vervolgens kan worden ‘doorgeklikt’ naar gescande documenten en tekeningen om de werkelijke situatie te bestuderen. Het grootste nadeel van deze oplossing is dat de representaties afzonderlijk van elkaar en ook niet-geïntegreerd met de kadastrale kaart staan opgeslagen.

Zowel de hybride oplossing als het eerste alternatief van het volledig 3D kadaster vereisen dat een 2.5D oppervlak van de grondpercelen beschikbaar is in de kadastrale registratie.

### **Realisatie van een 3D kadaster**

Op basis van technische en kadastrale criteria zijn de meest belovende conceptuele modellen voor de Nederlandse situatie geselecteerd. Dit zijn het eerste alternatief van het volledig 3D kadaster en, indien een kadastrale registratie nog niet ver genoeg is om volume percelen in te schrijven die niet gerelateerd zijn aan grondpercelen, beide alternatieven van het hybride kadaster. Deze conceptuele modellen zijn vertaald in logische modellen en in prototypes, waarna de prototypes zijn toegepast op case studies die eerder in dit proefschrift (bij de achtergrondanalyse) beschreven zijn. De hybride modellen zijn toegepast op Nederlandse casestudies omdat het Nederlandse kadaster nog steeds erg land (oppervlak) georiënteerd is. De juridische status van vastgoed wordt immers in alle gevallen vastgelegd door middel van de doorsneden grondpercelen. Het prototype van het volledig 3D kadaster is toegepast op een casestudie in Queensland omdat het daar reeds mogelijk is om 3D percelen te vestigen die geen enkele relatie meer hebben met de grondpercelen die worden doorsneden.

Door middel van de experimenten met de prototypes konden de verschillende conceptuele modellen en de prototypes worden geëvalueerd. Op basis van deze evaluatie kunnen de volgende conclusies worden getrokken.

Het eerste alternatief van het volledige 3D kadaster biedt de beste mogelijkheid om

de werkelijke eigendomssituatie in 3D vast te leggen, te visualiseren, te bevragen en te analyseren. De experimenten met het prototype hebben laten zien dat de juridische, organisatorische en technische aspecten van een 3D kadaster door middel van deze benadering op een fundamenteel niveau worden aangepakt en dat deze vorm van een 3D kadaster realiseerbaar is. Bovendien kunnen percelen met slechts één gebruiker nog steeds op de traditionele manier worden geregistreerd. De belangrijkste verbeteringen van het geselecteerde alternatief van het volledige 3D kadaster zijn dat de werkelijke eigendomssituatie niet langer wordt geprojecteerd op het oppervlak, dat personen op een logische manier een recht op een ruimte kunnen krijgen in plaats van deze personen een recht op de doorsneden percelen te geven en dat de ruimte van een eigendom nauwkeurig wordt beschreven in een 3D veldwerk waardoor 3D eigendommen uniform worden vastgelegd. Daarnaast biedt het volledige 3D kadaster ook verbeteringen voor kadastrale registraties die al in staat zijn om volume percelen te vestigen, omdat in het voorgestelde prototype de 3D beschrijving van de volume percelen in vector-formaat beschikbaar is en omdat deze beschrijving wordt geïntegreerd met de kadastrale registratie.

In dit proefschrift is echter ook steeds rekening gehouden met het bestaan van juridische doctrines, zoals in Nederland, waarbij de introductie van eigendomsruimten die niet langer gerelateerd zijn aan grondpercelen de nodige tijd en discussies zal vergen. Dit komt door het sterk land georiënteerde karakter van vastgoed binnen deze juridische doctrines. In deze gevallen zal een 3D kadaster dat inzicht moet bieden in 3D eigendomssituaties gebaat zijn met het hybride kadaster, zoals blijkt uit de experimenten met de prototypes. Hierbij worden, naast de perceelsregistratie, of de rechts-volumes geregistreerd of de 3D fysieke objecten als zodanig. Het hybride kadaster biedt inzicht in de eigendomssituatie in de derde dimensie wat een duidelijke verbetering is ten opzichte van de huidige kadastrale registratie. Door een mix van de twee voorgestelde hybride alternatieven kan het hybride kadaster optimaal worden geïmplementeerd. Het hybride kadaster toonde bij de toepassing op de casestudies nog wel enkele tekortkomingen.

### **Tot slot**

Multifunctioneel ruimtegebruik wordt steeds belangrijker en ook de manier waarop de mens met ruimte en dus met land omgaat, is drastisch veranderd gedurende de laatste 40 jaar (vastgoed is aanzienlijk gestegen in waarde). Daarom is het belangrijk dat huidige kadasters de ware aard van eigendomsrechten, waarbij personen een recht op een ruimte krijgen en niet alleen maar op een oppervlak, beter kunnen reflecteren. De bevindingen in dit onderzoek zouden daarom kadasters moeten motiveren om stappen te zetten in de richting van het volledige 3D kadaster zoals dat in dit proefschrift is gepresenteerd en geëvalueerd.

Dit proefschrift heeft de belangrijkste randvoorwaarden laten zien en geïmplementeerd om een volledig 3D kadaster te vestigen binnen bestaande (of toekomstige) juridische, kadastrale en technische kaders. Er zijn echter nog veel technische beperkingen weg te nemen voordat er commerciële tools beschikbaar zijn die nodig zijn om het volledige 3D kadaster, operationeel binnen een Geo-Informatie Infrastructuur, te kunnen ondersteunen. Daarnaast zullen ook nog veel juridische en kadastrale issues aangepakt moeten worden voordat fundamentele stappen gemaakt kunnen worden in de richting van een volledig 3D kadaster, in ieder geval in Nederland.



# Curriculum Vitae

Jantien Stoter (1971) graduated in Physical Geography at Utrecht University in 1995 before beginning her career as a GIS specialist with the District Water Board of Amsterdam (1995-1997). From 1997 till 1999 she worked as a GIS consultant at the Engineering Office of Holland Rail Consult where she applied GIS analyses to support the planning of large infrastructure projects. Stoter's university career started in 1999 as an assistant professor in GIS applications, section GIS technology, in the Department of Geodesy, Delft University of Technology. In 2000 she started this PhD research on 3D Cadastre, which resulted in a considerable number of articles and conference papers in addition to this thesis. In February 2004, she received the prof. J.M. Tienstra research-award for her work. This award, which is given every five years by the Netherlands Geodetic Commission (NCG) of the Royal Netherlands Academy of Arts and Sciences (KNAW), has been established to promote geodetic research in the Netherlands. Since April 2004 she holds the position of assistant professor at the International Institute for Geo-Information Science and Earth Observation, ITC, Enschede, the Netherlands. Her main research and education responsibilities are generalisation of geo-information and multi-scale databases.

